

- 7 different models.
- Cuts hardened nuts up to grade 8 & 2H.
- Safety, no sparks, no flame, no impact.
- Replacement chisel and set screws included.
- Cuts any shape nut.
- Cuts nuts from 1/2" to 2 15/16" (13 to 75mm).
- Rugged carrying case included.
- Broadest Range / Best Value.
- Angled head design for easy placement on nut.

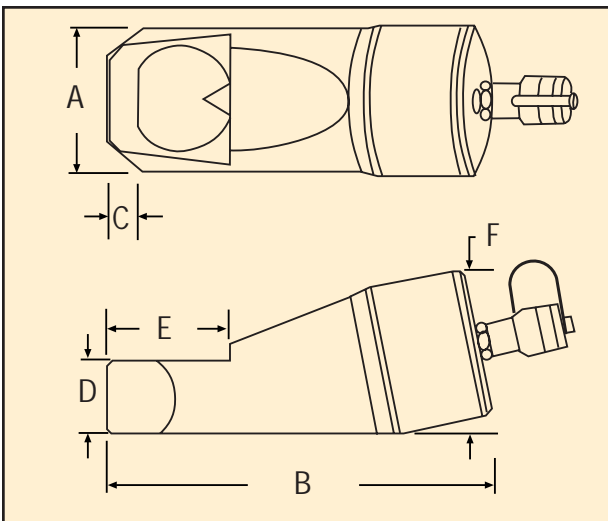

Refineries, steel mills and power plants rely heavily on Simplex nut splitters for removing stubborn or rusted nuts easily and safely. The Simplex nut splitters offer a wide range of sizes at exceptional values.



			
Torque Wrenches pgs. 94-99	Hand Pumps pgs. 32-35	Hoses pgs. 66-67	Pow'r-Buddy pgs. 40-41

Hydraulic Nut Splitters

Model Number	Stud Dia. (in.)	Nut A/F (in.)	Nut A/F Metric (mm)	A (in.)	B (in.)	C (in.)	D (in.)	E (in.)	F (in.)	Weight (lbs)	Sugstd. Hand Pump
NS1319	1/4 - 7/16	1/2 - 3/4	13 - 19	1.57	7.87	.24	.75	1.10	1.89	1.8	P42/P72
NS1924	7/16 - 9/16	3/4 - 15/16	19 - 24	2.17	8.94	.32	.98	1.50	2.80	4.4	
NS2432	9/16 - 3/4	15/16 - 1 1/4	24 - 32	2.60	10.24	.39	1.22	1.93	2.99	6.6	
NS3241	3/4 - 1	1 1/4 - 1 5/8	32 - 41	2.95	11.26	.59	1.38	2.60	3.50	9.7	
NS4150	1 - 1 1/4	1 5/8 - 2	41 - 50	3.78	12.80	.83	1.77	2.87	4.29	18.0	P140
NS5060	1 1/4 - 1 1/2	2 - 2 3/8	50 - 60	4.17	14.41	1.06	2.13	4.96	4.96	26.0	
NS6075	1 1/2 - 1 7/8	2 3/8 - 2 15/16	60 - 75	6.14	14.43	1.06	2.95	4.33	7.09	75.1	