

► How to Order and Specify

Example: Heavy Duty Metric Hydraulic Cylinder

Cap fixed clevis, 80mm bore x 200mm stroke, 45mm rod diameter with M33 x 2 x 45 longer male threads. Front and rear end caps have BSP hydraulic supply ports (G-ports) at *end cap side location 1*, cushions at *end cap side location 2* and nothing at *end cap side locations 3 and 4*. Viton seals are required.

End Cap Side Locations: **1 2 3 4** **1 2 3 4**

IHP 3 80 x 200 BL - GCNN - GCNN - / V

Position No: **A B C D E F G H J**

A Cylinder Model: Specify IHP in this position.

40mm bore through 500mm bore.
Nitrile seals with Teflon backup rings. (Std.)
Precision machined steel cylinder heads. (Std.)
Removable, self-aligning, bearing cartridge. (Std.)
"Slip Tuff" coated bearing cartridge for severe side loaded conditions (optional)
D.O.M. Seamless tube precision honed ID with thick wall. (STD)

100,000 PSI yield, "IHCP" chrome plated piston rod. (Std.)
Adjustable cushions with captive screw. (Cushions are optional)
In-port mounted proximity switches for near end of stroke position sensing (optional). Replaces mechanical limit switches.
Air bleed system (optional).
Rod cartridge drain back system (optional)

B Specify Cylinder Mounting Style: See inside for illustrations.

IHP 1 Foot Side Lugs (MS2)	IHP 12 Head & Cap Tie Rod Extended (MX1)
IHP 2 Head Trunnion (MT1)	IHP 17 Head Square Flange (MF5)
IHP 3 Cap Fixed Clevis (MP1)	IHP 18 Cap Square Flange (MF6)
IHP 6 Intermediate Trunnion (MT4) <i>(See XV note on back page)</i>	IHP 22 Cap Fixed Spherical Eye (MP5)
IHP 7 Cap Trunnion (MT2)	IHP 25 Cap Fixed Eye (MP3)
IHP 8 Head Tie Rod Extended (MX3)	IHP 28 Head Rectangular (ME5)
IHP 11 Cap Tie Rod Extended (MX2)	IHP 29 Cap Rectangular (ME6)

C Specify Cylinder Bore

40 = 40mm bore	200 = 200mm bore
50 = 50mm bore	250 = 250mm bore
63 = 63mm bore	320 = 320mm bore
80 = 80mm bore	360 = 360mm bore
100 = 100mm bore	400 = 400mm bore
125 = 125mm bore	500 = 500mm bore
160 = 160mm bore	

D Specify Stroke Length

Specify stroke length in millimeters from 25mm to 3,500mm.

For Stop Spool (Stop Tube) applications, contact Peninsular to determine call out for correct stroke length to specify.

E Specify Piston Rod Diameter and Rod Threads: See Rod Chart on next page.

F-G Specify Plumbing Configuration for Rod End Cover (F) and Cap End Cover (G)

- N** = No feature required, i.e. no supply port, no cushion adjustment screw, no prox. switch.
- G** = BSP hydraulic supply port – parallel thread (G-port).
- F** = 4-Bolt flange type hydraulic supply port (per ISO 6162 for bigger bores).
- W** = BPT hydraulic supply port – tapered thread (R-port).
- A** = NPTF hydraulic supply port – tapered pipe thread.
- T** = SAE straight o-ring thread, hydraulic supply port.
- C** = Cushion adjustment screw.
- M** = Proximity Switch Ready only, no switch mounted to the cylinder end cap.
- S** = Proximity Switch to be in-port mounted to the cylinder end cap. (complete position **H**)

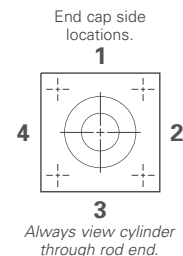

Metric Mounting Styles

ISO 6020-2, 40mm to 200mm Bores & ISO 6020-3, 250mm to 500mm Bores

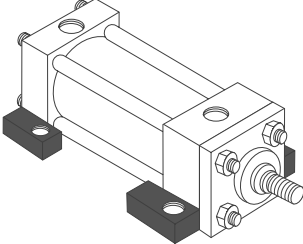
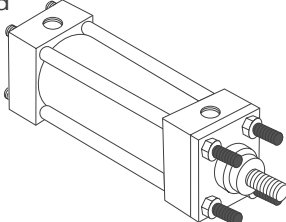
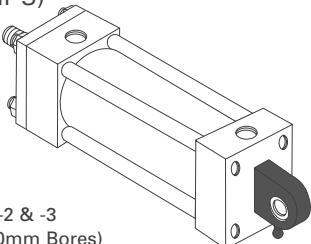
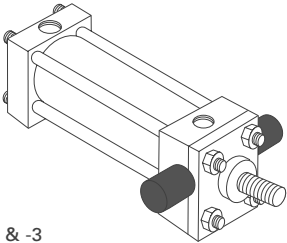
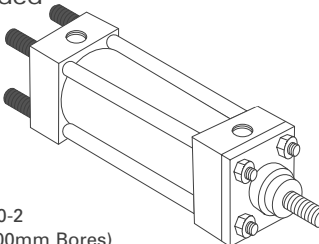
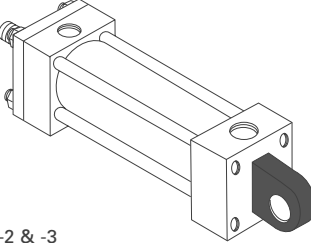
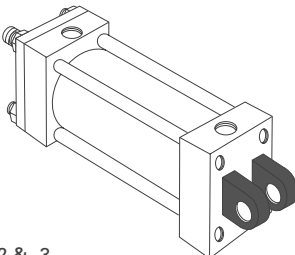
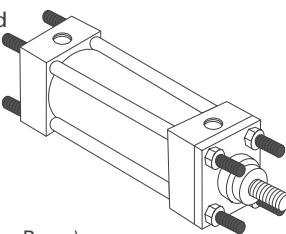
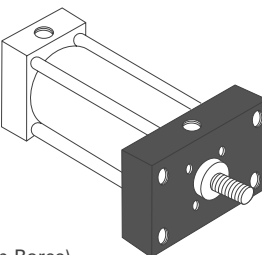
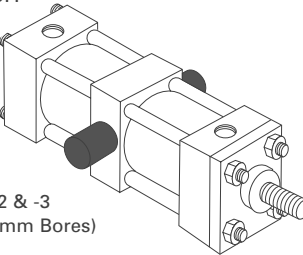
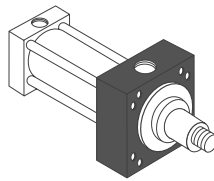
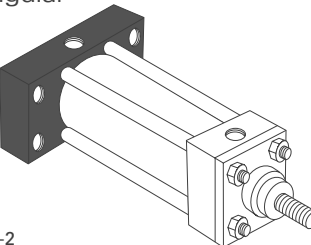
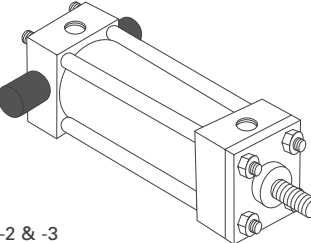
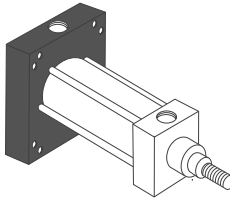
<p>IHP 1 Foot Side Lugs (MS2)</p>  <p>ISO 6020-2 (40 to 200mm Bores)</p>	<p>IHP 8 Head Tie Rod Extended (MX3)</p>  <p>ISO 6020-2 (40 to 200mm Bores)</p>	<p>IHP 22 Cap Fixed Spherical Eye (MP5)</p>  <p>ISO 6020-2 & -3 (40 to 500mm Bores)</p>
<p>IHP 2 Head Trunnion (MT1)</p>  <p>ISO 6020-2 & -3 (40 to 500mm Bores)</p>	<p>IHP 11 Cap Tie Rod Extended (MX2)</p>  <p>ISO 6020-2 (40 to 200mm Bores)</p>	<p>IHP 25 Cap-Fixed Eye (MP3)</p>  <p>ISO 6020-2 & -3 (40 to 500mm Bores)</p>
<p>IHP 3 Cap Fixed Clevis (MP1)</p>  <p>ISO 6020-2 & -3 (40 to 500mm Bores)</p>	<p>IHP 12 Head and Cap Tie Rod Extended (MX1)</p>  <p>ISO 6020-2 (40 to 200mm Bores)</p>	<p>IHP 28 Head Rectangular (ME5)</p>  <p>ISO 6020-2 (40 to 200mm Bores)</p>
<p>IHP 6 Intermediate Trunnion (MT4)</p>  <p>ISO 6020-2 & -3 (40 to 500mm Bores) *See note</p>	<p>IHP 17 Head Square Flange (MF5)</p>  <p>ISO 6020-3 (250 to 500mm Bores)</p>	<p>IHP 29 Cap Rectangular (ME6)</p>  <p>ISO 6020-2 (40 to 200mm Bores)</p>
<p>IHP 7 Cap Trunnion (MT2)</p>  <p>ISO 6020-2 & -3 (40 to 500mm Bores)</p>	<p>IHP 18 Cap Square Flange (MF6)</p>  <p>ISO 6020-3 (250 to 500mm Bores)</p>	

***Note:** Specify XV dimension at position "J" when ordering an intermediate trunnion cylinder (IHP 6). In the absence of an XV dimension, Peninsular will center the intermediate trunnion between the two end caps.

H Proximity Switches

Always leave position H blank unless proximity switches are required. If proximity switch application is required, contact Peninsular.

J Specify Optional Features with Slash Mark and Alpha Character(s)

/C Air Bleed	/I Cast Iron Piston Rings	/S Scraper Ring	/XV Specify XV Dimension (IHP6)
/D Drain Back	/L Lubricated Trunnion Pins	/V Viton Seals	/Y Double Rod End
/E Extended Piston Rod*	/N Stop Tube*	/W Withstands Corrosion	/Z "Slip Tuff" coated rod cartridge
/F Bronze Rod Cartridge	/P Oversize Ports (Specify)	/X Extended Key	/O Other options (describe)
/H Rod Boot Cover	/R Threaded Stud Rod End		* Specify Length

E Specify Piston Rod Diameter and Rod Threads

First letter denotes
Rod Diameter, specify:

- A = Standard Rod Diameter
- B = Larger Rod Diameter
- C = Oversized Rod Diameter

Second letter denotes
Rod Threads, specify:

- M = Shorter Male Rod Threads
- L = Longer Male Rod Threads
- F = Female Rod Threads

Other rod and thread sizes are available, please call Peninsular.

For ISO 6020-2 Bore Sizes = 40mm - 200mm				
Bore	Rod Dia.	Style M, Shorter Male	Style L, Longer Male	Style F, Female
40	A = 18	M10 x 1.25 x 14	M14 x 1.5 x 18	M12 x 1.25 x 18
	B = 28	M14 x 1.5 x 18	M20 x 1.5 x 28	M20 x 1.5 x 28
50	A = 22	M12 x 1.25 x 18	M16 x 1.5 x 22	M16 x 1.5 x 22
	B = 28	M16 x 1.5 x 22	M20 x 1.5 x 28	M20 x 1.5 x 28
	C = 36	M16 x 1.5 x 22	M27 x 2 x 36	M27 x 2 x 36
63	A = 28	M16 x 1.5 x 22	M20 x 1.5 x 28	M20 x 1.5 x 28
	B = 36	M20 x 1.5 x 28	M27 x 2 x 36	M27 x 2 x 36
	C = 45	M20 x 1.5 x 28	M33 x 2 x 45	M33 x 2 x 45
80	A = 36	M20 x 1.5 x 28	M27 x 2 x 36	M27 x 2 x 36
	B = 45	M27 x 2 x 36	M33 x 2 x 45	M33 x 2 x 45
	C = 56	M27 x 2 x 36	M42 x 2 x 56	M42 x 2 x 56
100	A = 45	M27 x 2 x 36	M33 x 2 x 45	M33 x 2 x 45
	B = 56	M33 x 2 x 45	M42 x 2 x 56	M42 x 2 x 56
	C = 70	M33 x 2 x 45	M48 x 2 x 63	M48 x 2 x 63
125	A = 56	M33 x 2 x 45	M42 x 2 x 56	M42 x 2 x 56
	B = 70	M42 x 2 x 56	M48 x 2 x 63	M48 x 2 x 63
	C = 90	M42 x 2 x 56	M64 x 3 x 85	M64 x 3 x 85
160	A = 70	M42 x 2 x 56	M48 x 2 x 63	M48 x 2 x 63
	B = 90	M48 x 2 x 63	M64 x 3 x 85	M64 x 3 x 85
	C = 110	M48 x 2 x 63	M80 x 3 x 95	M80 x 3 x 95
200	A = 90	M48 x 2 x 63	M64 x 3 x 85	M64 x 3 x 85
	B = 110	M64 x 3 x 85	M80 x 3 x 95	M80 x 3 x 95
	C = 140	M64 x 3 x 85	M100 x 3 x 112	M100 x 3 x 112
For ISO 6020-3 Bore Sizes = 250mm - 500mm				
Bore	Rod Dia.	Style M, Shorter Male	Style L, Longer Male	Style F, Female
250	A = 140	M100 x 3 x 112	M100 x 3 x 165	M100 x 3 x 112
	B = 160	M110 x 3 x 112	M110 x 3 x 165	M110 x 3 x 112
	C = 180	M125 x 4 x 125	M125 x 4 x 185	M125 x 4 x 125
320	A = 180	M125 x 4 x 125	M125 x 4 x 185	M125 x 4 x 125
	B = 200	M140 x 4 x 140	M140 x 4 x 210	M140 x 4 x 140
	C = 220	M160 x 4 x 160	M160 x 4 x 240	M160 x 4 x 160
360	A = 180	M125 x 4 x 125	M125 x 4 x 185	M125 x 4 x 125
	B = 220	M160 x 4 x 160	M160 x 4 x 240	M160 x 4 x 160
	C = 250	M180 x 4 x 180	M180 x 4 x 270	M180 x 4 x 180
400	A = 220	M160 x 4 x 160	M160 x 4 x 240	M160 x 4 x 160
	B = 250	M180 x 4 x 180	M180 x 4 x 270	M180 x 4 x 180
	C = 280	M200 x 4 x 200	M200 x 4 x 300	M200 x 4 x 200
500	A = 280	M200 x 4 x 200	M200 x 4 x 300	M200 x 4 x 200
	B = 320	M220 x 4 x 220	M220 x 4 x 325	M220 x 4 x 220
	C = 360	M250 x 6 x 250	M250 x 6 x 375	M250 x 6 x 250



Peninsular Cylinder Company® • 27650 Groesbeck Hwy. • Roseville, MI 48066-2759
 phone: (586) 775-7211 • fax: (586) 775-4545 • toll-free: 1-800-526-7968
 e-mail: sales@peninsularcylinders.com • www.peninsularcylinders.com