

OETIKER

Miniature Clamps



Medical
Bio-medical
Pharmaceutical



Scientific Instruments
Electrical / Electronic
Connections



Computer



Communication

Robotic Equipment



Connecting Technology





OETIKER

Connecting Technology

Miniature Clamps

Contents

- 3** OETIKER Clamps – Product Chart – Technical Information
- 4** OETIKER 2-Ear Clamps – 101 & 151
- 5** OETIKER 1-Ear Clamps – 153
- 6** OETIKER 1-Ear Clamps with Insert – 154
- 7** OETIKER Stepless® Ear Clamps – 167
- 8** OETIKER Miniature Multi Crimp Rings – 150
- 9** OETIKER Clamp Installation Instructions
- 10** OETIKER Typical Medical Applications
- 11** OETIKER Typical Electrical Applications

The OETIKER Group World-Wide

It is and shall continue to be a primary objective of the OETIKER Group to provide customers with safe, reliable products. OETIKER revolutionized the art of clamping hose, tubing and other objects made of common and the most difficult to seal and fasten materials. The company is committed to providing products that are continuously tested and evaluated to assure the highest standard in quality and performance.

Founded in Switzerland in 1943, today the OETIKER Group is a multinational company and is networked to provide a full complement of customer service, design and engineering support.

OETIKER manufactures product through strategically located facilities throughout the world. The products are manufactured to common standards, and are available through OETIKER sales offices in many countries, and selected distributors. The OETIKER name is trademark protected and the history of many patents is evidence of the importance of the OETIKER name in clamping and coupling technology the world over. The OETIKER Logo signifies that the product has been produced to quality standards demanded by the founder, Hans Oetiker, and customers world wide.

Quality Standards

All companies within the OETIKER group have quality certification in accordance with ISO/TS 16949 standards for production, research and development and ISO 9002 for sales and supply. Most OETIKER Clamps conform to SAE J1508 specifications.



OETIKER Miniature Clamps Product Chart



Page	Clamp Type	Product Group	Size Range mm	Width mm	Thickness mm	Zinc Plated	Stainless
4	2-Ear Clamps	101 & 151	4.1 - 46.0	3.5 - 10.0		x	x
5	1-Ear Clamps	153	3.3 - 17.5	3.0 - 6.0			x
6	1-Ear Clamps with Insert	154	2.9 - 17.5	5.5 - 8.2			x
7	Stepless* Ear Clamps	167	6.5 - 120.5	5.0 - 10.0	0.5 - 1.0		x
8	Stepless* Low Profile Clamps	168	10.5 - 19.0	0 - 0	9.0 x 0.5		x
8	Miniature Multi Crimp Rings	150	0 - 0	0 - 0	0 - 0		x

High Tech Hose and Tubing Connections for Medical, Bio-medical, Pharmaceutical Industries as well as Scientific Instruments and Devices.

For Electrical / Electronic Connections on Computer, Communication, Robotic Equipment or Automotive Harnesses, etc.

OETIKER Miniature Clamps

for applications calling for top quality precision clamping, on which a life may depend.

OETIKER Miniature Clamps

are used on equipment such as endoscopic and videoscopic instruments, peristaltic and other types of medical pumps, blood and gas analysers, dialysis equipment, filtration, disposables, respiratory, etc. They are seal-assured so that no cross-contamination, and no leakage of contaminated fluid can occur.

OETIKER Miniature Clamps

2-Ear Clamp style – are especially popular as a strain relief for single or multiple wire conductor cables or insulation. They provide excellent tri-directional protection and are suitable for insert and overlay molding.

OETIKER Miniature Clamps

stepless – because of their interior design, will not damage low durometer and soft thin-walled hose or silicone material, stiff synthetic tubing or any insulation material. Clamps will prevent leakage and negative pressures will be held steady.

OETIKER Miniature Clamps and Rings

for outside diameters as small as 2.5 mm to assure leak-free sealing and fastening solutions. Suitable for hose supply lines with chemicals, ink, liquids and gases. Clamps are vibration proof.

OETIKER products are used in a wide range of materials in industries such as to name a few:

- communication, computerized equipment
- electrical control systems and wiring
- food and beverage dispensing equipment
- housing construction, mobile homes, recreational vehicles
- medical and life-support systems
- pharmaceutical, scientific instruments
- plant maintenance, heavily vibrating equipment
- automobiles, auto aftermarket
- off-road equipment

OETIKER 2-Ear Clamps

Product Group **101 & 151**



original size

This is the first "original" OETIKER Ear Clamp invented. It came onto the market in 1951 and revolutionized clamping. To this day, it has remained a best-seller.

The 2-ear clamp has an increased clamping range over the 1-ear clamps. The closed "ear" geometry provides an inherent retained load and a spring action in the clamp, permitting expansion and contraction during thermocycling or vibrating conditions. For proper installation and seal, both "ears" must be crimped closed.

Material

- 101 Zinc plated carbon steel SAE 1008/1010 or DIN 1.0338
- 151 Stainless steel UNS S30400 or DIN 1.4301

Clamp size range

4.1 - 46.0 mm

Installation

See page 9.



Features

- robust, durable one-piece design offers positive, tamper resistant seal
- for air and fluid media lines
- one-piece design offers quick and easy installation
- smooth edges prevent damage to hose

Standard Series

item no. zinc plated	item no. stainless steel	size ref. mm	clamp range mm	clamp range inches	width mm
10100000	15100000	4.1	3.1 - 4.1	.122 - .161	3.5
10100001	15100001	4.5	3.5 - 4.5	.138 - .177	3.5
10100002	15100002	5.0	3.4 - 5.0	.134 - .197	5.0
10100004	15100003	7.0	5.0 - 7.0	.197 - .276	6.0
10100008	15100004	9.0	7.0 - 9.0	.276 - .354	7.0
10100011	15100023	11.0	8.1 - 11.0	.319 - .433	7.0
10100016	15100006	13.0	10.8 - 13.0	.425 - .512	7.0

Narrow Width Series – 3 mm wide

item no. zinc plated	item no. stainless steel	size ref. mm	clamp range mm	clamp range inches	width mm
10100003	15100031	5	3.4 - 5.0	.134 - .197	3.0
10100005	15100033	7	5.0 - 7.0	.197 - .276	3.0
10100009	15100029	9	7.0 - 9.0	.276 - .354	3.0
10100012	15100051	11	8.0 - 11.0	.315 - .433	3.0
10100016	15100028	13	11.0 - 13.0	.433 - .512	3.0

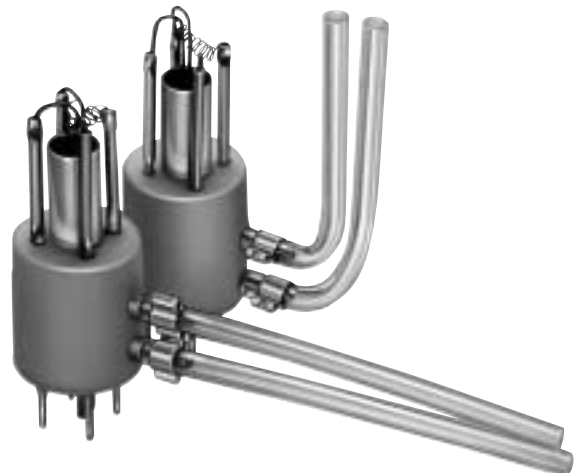

OETIKER 1-Ear Clamps

Product Group **153**



Features

- popular for miniature sizes 3.3 mm
- smallest closing dia. is 2.9 mm (.114 in.) #9 French Catheter Scale
- one-piece design offers quick and easy installation
- for air and fluid media lines
- commonly used where a low profile protrusion and a small, snug clamp range is of the essence

item no. stainless steel	size ref. mm	clamp range mm	clamp range inches	width mm
15300000	3.3	2.9 - 3.3	.114 - .130	3.0
15300001	3.5	3.0 - 3.5	.118 - .138	3.0
15300002	4.1	3.3 - 4.1	.130 - .161	4.0
15300046	4.6	3.7 - 4.6	.146 - .181	4.0
15300003	5.1	4.1 - 5.1	.161 - .201	4.0
15300047	5.6	4.5 - 5.6	.181 - .220	4.0
15300004	6.1	5.1 - 6.1	.201 - .240	4.0
15300005	6.6	5.6 - 6.6	.221 - .260	4.0
15300006	7.0	6.1 - 7.0	.240 - .276	4.0
15300007	7.5	6.5 - 7.5	.256 - .296	5.0
15300008	8.0	6.8 - 8.0	.268 - .315	5.0
15300009	8.3	7.1 - 8.3	.280 - .327	5.0
15300010	8.7	7.5 - 8.7	.295 - .343	5.0
15300011	9.0	7.5 - 9.0	.295 - .354	6.0
15300012	9.5	8.1 - 9.5	.312 - .374	6.0
15300013	10.0	8.5 - 10.0	.335 - .394	6.0
15300014	10.5	9.1 - 10.5	.358 - .413	6.0
15300015	11.0	9.3 - 11.0	.366 - .433	6.0
15300016	11.3	9.6 - 11.3	.378 - .445	6.0
15300017	11.8	10.1 - 11.8	.398 - .465	6.0

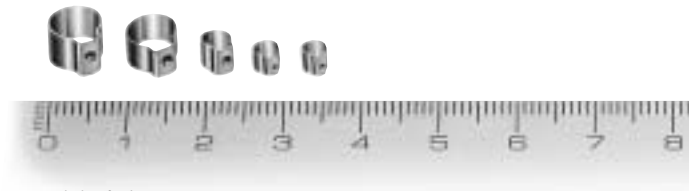

original size

OETIKER 1-Ear Clamps are commonly used where a low profile protrusion and a small, snug clamp is of the essence.

Material

– 153 Stainless steel UNS S30400 or DIN 1.4301

clamp size range

3.3 - 17.5 mm

Installation

See page 9.



OETIKER

1-Ear Clamps with Insert

Product Group **154**



OETIKER 1-Ear Clamps (with Insert) are ideal for very demanding hose or tubing clamping applications, such as rubber or synthetic materials.

The thin "Insert" has an oval outward dimple which is positioned precisely under the clamp ear, effectively preventing material from being lifted into the ear gap during clamp closure. This double dimple combination in the insert and clamp creates a particularly strong all-around effective compression seal.

Ideally suited for inkjet printer hose connections, for automotive, medical, pharmaceutical and scientific instrument grade hose and tubing, and a wide variety of applications.

Material

- 154 Clamp: Stainless steel UNS S30400 or DIN 1.4301
 Insert: Stainless steel UNS S30200 or DIN 1.4310

Clamp size range

2.9 - 17.5 mm
 larger sizes on request

Installation

See page 9.

Features

- Clamps can be effectively closed as small as 2.5 mm (.098 in) – # 8 French Catheter Scale
- the curled edges of the "insert" prevent cutting or damage to hose or tubing materials particularly when subjected to strong pulsation, expansion and contraction
- light weight, strong and tamper resistant

item no.	size ref.	clamp range		width
stainless steel	mm	mm	inches	mm
15400010	3.3	2.5 - 2.9	.098 - .114	5.5
15400011	3.5	2.7 - 3.1	.106 - .122	5.5
15400012	4.1	2.9 - 3.7	.114 - .146	5.5
15400054	4.6	3.3 - 4.2	.130 - .165	5.5
15400013	5.1	3.7 - 4.7	.146 - .185	5.5
15400055	5.6	4.2 - 5.2	.165 - .205	5.5
15400014	6.1	4.7 - 5.7	.185 - .224	5.5
15400015	6.6	5.2 - 6.2	.205 - .244	5.5
15400016	7.0	5.6 - 6.5	.220 - .256	6.4
15400017	7.5	5.9 - 7.0	.232 - .276	6.4
15400018	8.0	6.3 - 7.5	.248 - .291	6.4
15400019	8.3	6.6 - 7.8	.260 - .307	6.4
15400020	8.7	7.0 - 8.2	.275 - .323	6.4
15400021	9.0	7.0 - 8.5	.276 - .335	7.4
15400022	9.5	7.5 - 9.0	.295 - .354	7.4
15400023	10.0	8.0 - 9.5	.315 - .374	7.4
15400024	10.5	8.5 - 10.0	.335 - .394	7.4
15400025	11.0	8.8 - 10.5	.347 - .413	7.4
15400026	11.3	9.1 - 10.8	.358 - .425	7.4
15400027	11.8	9.6 - 11.3	.378 - .445	7.4



OETIKER Stepless® Ear Clamps

Product Group **167**



Features

- precise tongue-in-groove stepless design provides smooth, inner band circumference for 360° uniform seal
- narrow band for concentrated seal compression
- smooth edged bandsteel prevents damage to hose
- light weight, strong low clearance design



item no. standard	item no. degreased	size ref. mm	clamp range mm	clamp range inches	width mm
16702453	16702487	6.5	5.3 - 6.5	.209 - .256	5.0
16700001	16700983	7.0	5.8 - 7.0	.228 - .275	5.0
	16703192	7.5	6.3 - 7.5	.248 - .295	5.0
16700002	16700984	8.0	6.8 - 8.0	.268 - .315	5.0
16700003	16700985	8.7	7.0 - 8.7	.275 - .343	5.0
16700004	16700986	9.5	7.8 - 9.5	.307 - .374	5.0
16700005	16700987	10.0	8.3 - 10.0	.327 - .394	5.0
16700006	16700988	10.5	8.8 - 10.5	.347 - .413	5.0
16702492	16702614	10.9	8.2 - 10.9	.378 - .429	5.0
16700007	16702989	11.3	9.8 - 11.3	.398 - .445	5.0
16700008	16700990	11.8	10.1 - 11.8	.395 - .453	5.0

The term "Stepless" relates to the absence of gaps or steps on the clamp's inner circumference. The unique tongue-in-groove design provides uniform compression and a 360° seal.

Standard Series Stepless Ear Clamps were perfected for demanding applications where lighter, thin-walled hose or tubing is being used.

Stepless Ear Clamps are available in a variety of styles for Low Profile or Heavy Duty Clamping. Request separate catalog.

Material

- 167 Stainless steel band UNS S30400 or DIN 1.4301
- Alternate materials optional such as UNS S31600 or DIN 1.4401, 400 or 500 monel

Standard Series

clamp size range	width / thickness
6.5 - 11.8 mm	5.0 x 0.5 mm
11.9 - 120.5 mm	7.0 x 0.6 mm
21.0 - 120.5 mm	9.0 x 0.6 mm

Clamp Installation

See page 9.





OETIKER Stepless® Low Profile Clamps

Product Group **168**

Features

- where clearance is of the essence
- minimal imbalance on rotating parts
- precise tongue-in-groove stepless design provides smooth, inner band circumference for 360° uniform seal
- smooth edged bandsteel prevents damage to hose
- reusable

OETIKER Stepless Low Profile Clamps with only a scant 1.6 mm protrusion from outside of clamp band have been developed for applications with clearance restrictions. They are custom sized to assure the correct compression ratio for individual applications. Clamp designs vary and they may be custom shaped.

OETIKER Stepless Low Profile Clamps do not have the inherent spring action normally provided by OETIKER Clamps with an "Ear". Their seal retention relies solely on the expansion force created by the elasticity of the material being clamped.

OETIKER Stepless Low Profile Clamps are reusable for service and inspections. These clamps can be opened and re-installed several times and can be wrapped around an assembly.



Material

- 168 Stainless steel band UNS S30400 or DIN 1.4301
- Alternate materials optional

<i>clamp size range</i>	<i>width / thickness</i>
10.5 - 19.0 mm	9.0 x 0.5 mm
19.5 - 110.0 mm	7.0 x 0.6 mm
25.0 - 120.0 mm	9.0 x 0.6 mm

larger sizes on request

Installation

Installation instructions on request.

OETIKER Miniature Multi Crimp Rings

Product Group **150**

Features

- for diameters as small as 2.1 mm (.083")
- precise closure due to consistent smooth interior seal
- no outside protrusion to damage delicate components

Specifically suited for medical devices, scientific or diagnostic instruments and other small diameter tubing applications. Typical thread wraps, UV bond and adhesives, etc. are both time consuming, non-consistent and often have a relatively high failure rate. These Multi Crimp Rings will seal tubing such as silicone, polyurethane, PVC, to name a few.

Material

- 150 stainless steel UNS S30400 or DIN 1.4301

Clamp Installation

See page 9.



OETIKER Clamps Installation and Tools

Product Group **141 & 144**



Careful selection and installation of an OETIKER clamp is important to ensure a proper seal or fastened application. OETIKER supplied or recommended tools should be used. OETIKER Ear Clamps are intended for one-time use only. Prying open the clamp renders the product non-functional. Tampering is visible.

For proper installation and seal, the ear(s) must be crimped closed.

- As a guide: select size nearest to, yet slightly larger than outside diameter to be clamped with connection fully assembled

OETIKER invites customers to submit samples with relevant application information, to determine the best suited clamp for your product and installation method.



Item no. 14100117
Narrow Jaw Pincers

Item no. 14100183
Side Jaw Pincers

Item no. 14100118
Standard Pincers



Item no. 14100120
Miniature Clamp Pincers with adjustable closure stop for clamps up to 11.8 mm diameter.

Item no. 14100085
Miniature Clamp Pincers without adjustable closure stop (not shown)

Miniature Clamp Pincers may be autoclaved

Installation example

Position clamp on hose with end fitting inserted.
Close clamp ear(s) fully.



opening permissible
after crimping
use of straight jaw pincers



use of side jaw pincers
held parallel to hose



use of pneumatic power tool



Remove clamp by cutting
through outer edge of ear with
pincers.



To remove stepless or adjustable
clamps, grip band end and pull
over ear.



OETIKER

Typical Medical Applications



OETIKER Miniature Clamps –
smallest closure is 2.5 mm / .098"



2-Ear Clamp provides a strong leak-proof seal on dispensing equipment component.



OETIKER Clamps provide a strong, tamper resistant seal that will not damage medical / pharmaceutical or food and beverage grade hose and tubing.



Miniature 1-Ear Clamps with insert ensure a positive seal on this high vacuum application.



OETIKER Ear Clamp maintains a 360° seal on this critical component for a medical breathing device. Quick, positive seal without damaging delicate plastic.



OETIKER 1-Ear Clamps with insert are designed for demanding, difficult to seal nylon or wire braided hoses or tubing.

OETIKER Typical Electrical Applications



①



②



③



- ① 2-Ear Clamp for tri-directional strain relief protection.
- ② 2-Ear Clamp for strain relief.
- ③ 2-Ear Clamp for tri-directional strain relief protection – symmetrical clamp “ears” sit precisely in molded groove.

2-Ear Clamp holding a cable loop in place ensuring a non-slip grip.



1-Ear Clamp securing a plastic cap onto a fabric buffer and quartz glass tube. Strong seal, yet will not crack the quartz tube.



1-Ear Clamp provides strain relief on multi-conductor electrical cables



2-Ear Clamp maintaining a critical seal – meshgrounding onto a substrate of co-axial cable.

OETIKER

Miniature Clamps

for Medical and Electrical Applications

OETIKER Products

Clamps and Rings

Permanent, tight connection will only be released if required.
 For all clamping and pressure ranges, hard or soft materials, hoses, cables or ropes.
 Made from tube or band, stepless, self-tensioning or reusable.
 Simple and straightforward to use.
 Tools and accessories available.



Couplings

Swing Couplings SC:
 Safely swing to connect. Connect easily and quickly with no force required and no loss of pressure in the system. Full flow. Compatible with most current adaptor profiles.

Quick Action Couplings SV:*
 Fast and safe connection due to two-stage uncoupling. Various models available. Extensive range of accessories.

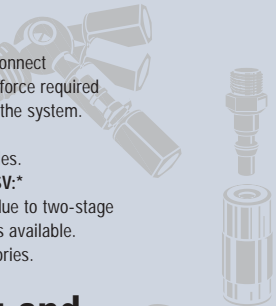

Sandblasting and Surface Technique*

Sandblasting Technique:
 Sandblasting equipment, jet rooms and cubicles, recovery and filter plants, safety equipment.

ROTOL Surface Technique:
 Deburring and polishing machines, treatment materials, planning and setting up of complete plants for effective surface treatment and refining.



Special Products*

Research and development of products as well as solutions for them to be integrated into assembly procedures internally or on customer's request repeatedly lead to innovative special products such as the dismantlable OETIKER crutch holder.

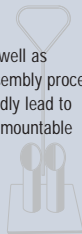

* Only available from Switzerland

Internet: www.oetiker.com

www.oetiker.com

OETIKER has been developing connecting technology for over 50 years. OETIKER products are manufactured by its own companies in line with ISO/TS 16949 and sold worldwide by subsidiary companies or agents in over 40 countries. Numerous patents are proof of continuous innovation.

OETIKER 2-Ear Clamps

101 & 151

OETIKER 1-Ear Clamps

153

OETIKER 1-Ear Clamps with Insert

154

OETIKER Stepless® Ear Clamps

167

OETIKER Stepless® Low Profile Clamps

168

OETIKER Miniature Multi Crimp Rings

150

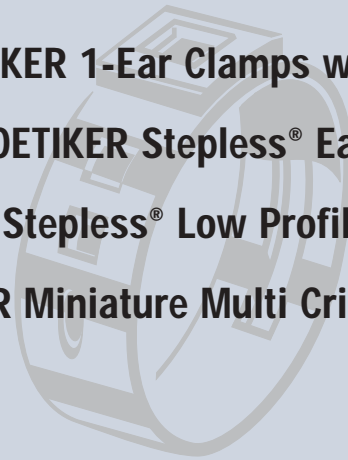

SWITZERLAND **Hans Oetiker AG**
Maschinen- und
Apparatefabrik
 Oberdorfstrasse 21
 CH-8812 Horgen (Zurich)
 Phone +41 (1) 728 55 55
 Fax +41 (1) 728 55 15
 e-mail info@ch.oetiker.com

USA 
Oetiker Inc.
 3305 Wilson Street
 Marlette, Michigan
 MI 48453-0217 – USA
 Phone +1 (989) 635 3621
 Fax +1 (989) 635 2157
 e-mail info@mi.usa.oetiker.com

CANADA 
Oetiker Limited
 203 Dufferin Street South
 Alliston, Ontario L9R 1W7
 Canada
 Phone +1 (705) 435 4394
 Fax +1 (705) 435 3155
 e-mail info@ca.oetiker.com