

Section A

Series 2H Heavy Duty Hydraulic Cylinders

1.50" Through 6.00" Bore

Performance	2
Specifications and Mounting Styles	3
Cylinder Features	4-5
Application Check List	6
Mounting Styles & Tips for Applying	7
2H Cylinder Model Code & How To Order	8-9
Rod End Styles and Dimensions	10-11
TD, TB, TC Mount Dimensions	12
J Mount Dimensions	13
JB Mount Dimensions	14
JJ Mount Dimensions	15
H Mount Dimensions	16
HB Mount Dimensions	17
HH Mount Dimensions	18
C Mount Dimensions	19
F Mount Dimensions	20
BB Mount Dimensions	21
D Mount Dimensions	22
DB Mount Dimensions	23
DD Mount Dimensions	24
DE Mount Dimensions	25
SB Mount Dimensions	26
Double Rod End Cylinders	27
2HD & 3HD Bolt-On Gland Option	28



Parker Series 2H Heavy Duty Hydraulic Cylinder

Series 2H cylinders set the standard for performance, durability, and trouble free operation. Parker superior design, the use of high quality materials and stringent manufacturing practices provide all customers with long cylinder service life and reduced operating costs. Patented design features such as the “Jewel” rod gland, hard chrome plated piston rods, and stepped cushions provide increased machine productivity through reduced downtime, faster cycle times, and improved system efficiency. Every Parker cylinder is individually tested before leaving our plant to assure proper performance and leak free operation. All Parker Cylinder products carry an 18 month warranty.

Select Parker Series 2H cylinder for your hydraulic cylinder requirements. Parker Series 2H will provide the value and performance you need for all of your industrial hydraulic application demands.

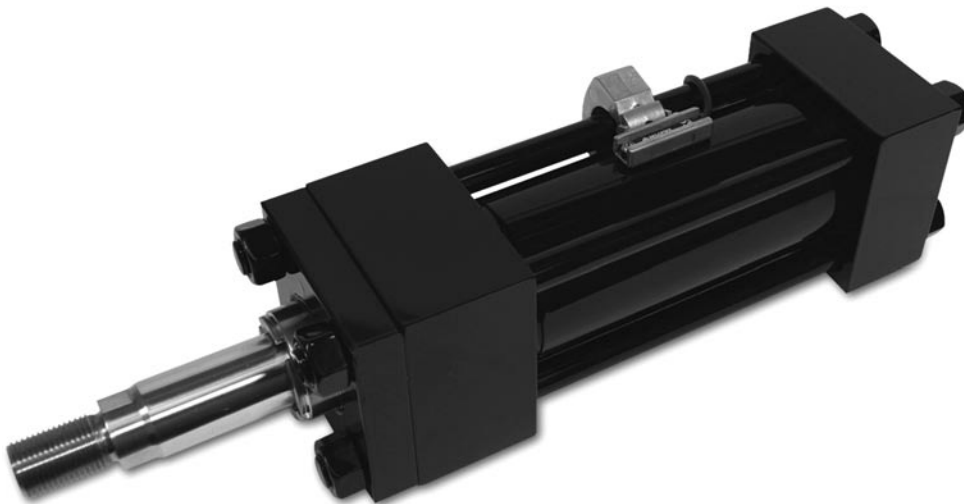

Standard Specifications

- Heavy Duty Service – ANSI/(NFPA) T3.6.7R2 - 1996 Specifications and Mounting Dimension Standards
- Standard Construction – Square Head – Tie Rod Design
- Nominal Pressure – 3000 psi¹
- Standard Fluid – Hydraulic Oil
- Standard Temperature – -10°F to +165°F²
- Bore Diameters – 1.50" through 6.00" (Larger sizes available)

In line with our policy of continuing product improvement, specifications in this catalog are subject to change.

Note: Series 2H Hydraulic Cylinders fully meet ANSI/(NFPA) T3.6.7R2 - 1996 Specifications and Mounting Dimension Standards for Square Head Industrial Fluid Power Cylinders.

- Piston Rod Diameter – .625" through 4.000"
- Mounting Styles – 18 standard styles at various application ratings
- Strokes – Available in any practical stroke length
- Cushions – Optional at either end or both ends of stroke. "Float Check" at cap end.
- Rod Ends – Four Standard Choices – Specials to Order

¹ If hydraulic operating pressure exceeds 3000 psi, send application data for engineering evaluation and recommendation. See Section E for actual design factors.

² See Section E for higher temperature service.



Available Mounting Styles

<p>Basic Style T 1.50" - 6.00"</p> <p>(NFPA MX0)</p>	<p>Tie Rods Extended Head End Style TB 1.50" - 6.00"</p> <p>(NFPA MX3)</p>	<p>Tie Rods Extended Cap End Style TC 1.50" - 6.00"</p> <p>(NFPA MX2)</p>	<p>Tie Rods Extended Both Ends Style TD 1.50" - 6.00"</p> <p>(NFPA MX1)</p>
<p>Head Rectangular Flange Style J 1.50" - 6.00"</p> <p>(NFPA MF1)</p>	<p>Head Square Flange Style JB 1.50" - 6.00"</p> <p>(NFPA MF5)</p>	<p>Head Rectangular Style JJ 1.50" - 6.00"</p> <p>(NFPA ME5)</p>	<p>Cap Rectangular Flange Style H 1.50" - 6.00"</p> <p>(NFPA MF2)</p>
<p>Cap Square Flange Style HB 1.50" - 6.00"</p> <p>(NFPA MF6)</p>	<p>Cap Rectangular Style HH 1.50" - 6.00"</p> <p>(NFPA ME6)</p>	<p>Side Lug Style C 1.50" - 6.00"</p> <p>(NFPA MS2)</p>	<p>Side Tapped Style F 1.50" - 6.00"</p> <p>(NFPA MS4)</p>
<p>Cap Fixed Clevis Style BB 1.50" - 6.00"</p> <p>(NFPA MP1)</p>	<p>Head Trunnion Style D 1.50" - 6.00"</p> <p>(NFPA MT1)</p>	<p>Cap Trunnion Style DB 1.50" - 6.00"</p> <p>(NFPA MT2)</p>	<p>Intermediate Fixed Trunnion Style DD 1.50" - 6.00"</p> <p>(NFPA MT4)</p>
<p>HD Intermediate Fixed Trunnion Style DE 4.00" - 6.00"</p> <p>(NFPA MT4)</p>	<p>Spherical Bearing Style SB 1.50" - 6.00"</p>	<p>Double Rod Cylinders Style KT Shown 1.50" - 6.00"</p> <p>Most of the above illustrated mounting styles are available in double rod cylinders.</p>	

The inside story on why Series 2H is your best choice in heavy duty hydraulic cylinders

Primary Seal – TS-2000 Rod Seal is a proven leakproof design – completely self-compensating and self-relieving to withstand variations and conform to mechanical deflection that may occur.

“Jewel” Rod Gland Assembly – Externally removable without cylinder disassembly. Long bearing surface is inboard of the seals, assuring positive lubrication from within the cylinder. An o-ring is used as a seal between gland and head, and also serves as a prevailing torque-type lock.

Secondary Seal – Double-Service Wiperseal® (Hannifin Patent #2907596) – wiperseals clean any oil film adhering to the rod on the extend stroke and cleans the rod on the return stroke.

Piston Rod Stud – Furnished on 2.000" diameter rods and smaller when standard style #4 rod end threads are required. Studs have rolled threads and are made from high strength steel. Anaerobic adhesive is used to permanently lock the stud to the piston rod.

Piston Rod – Medium carbon steel, induction case-hardened, hard chrome-plated and polished to 10 RMS finish. Piston rods are made from 90,000 to 100,000 psi minimum yield material in .625" through 4.000" diameters. Larger diameters vary between 57,000 and 90,000 psi minimum material, depending on rod diameter.

End Seals – Pressure-actuated cylinder body-to-head and cap o-rings.

Steel Head – Bored and grooved to provide concentricity for mating parts.

High Strength Tie Rods – Made from 100,000 psi minimum yield steel with rolled threads for added strength.

Ports – SAE “O” ring ports are standard.

Optional Ports

Ports – NPTF ports are optional at no extra charge. Oversize NPTF and SAE ports are available at extra charge.

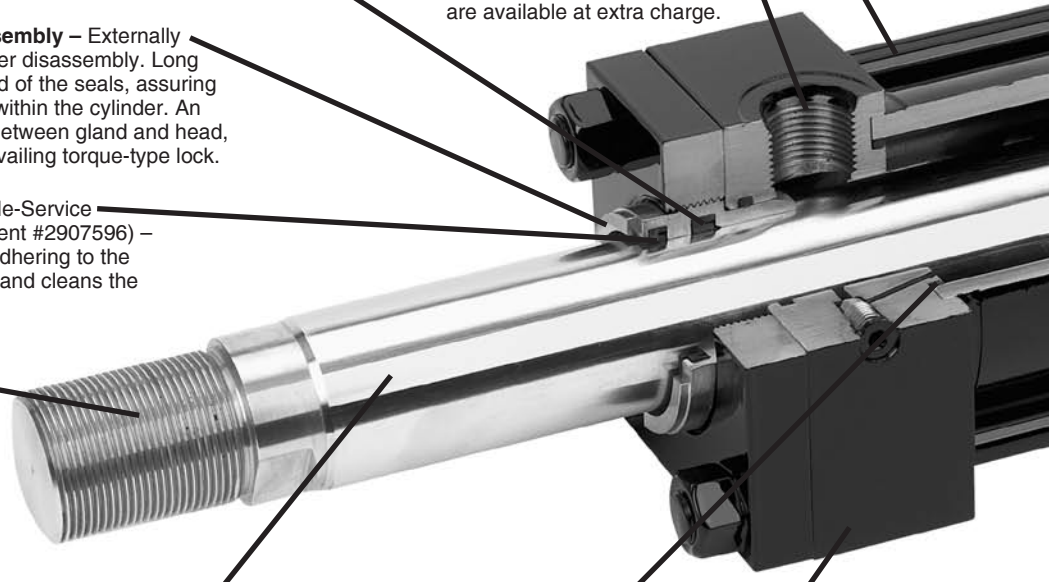

Parker’s Exclusive Stepped floating cushions combine the best features of known cushion technology.

Deceleration devices or built-in “cushions” are optional and can be supplied at head end, cap end, or both ends without change in envelope or mounting dimensions. Parker cylinder cushions are a stepped design and combine the best features of known cushion technology.

Standard straight or tapered cushions have been used in industrial cylinders over a very broad range of applications. Parker research has found that both designs have their limitations.

As a result, Parker has taken a new approach in cushioning of industrial hydraulic cylinders and for specific load and velocity conditions have been able to obtain deceleration curves that come very close to the ideal. The success lies in a stepped sleeve or spear concept where the steps are calculated to approximate theoretical orifice area curves.

In the cushion performance chart, pressure traces show the results of typical orifice flow conditions. Tests of a three-step sleeve or spear show three pressure pulses coinciding with the

steps. The deceleration cushion plunger curves shape comes very close to being theoretical, with the exception of the last 1/2 inch of travel. This is a constant shape in order to have some flexibility in application. The stepped cushion design shows reduced pressure peaks for most load and speed conditions, with comparable reduction of objectionable stopping forces being transmitted to the load and the support structure.

All Parker Hannifin cushions are adjustable.

The Series 2H cylinder design incorporates the longest cushion sleeve and cushion spear that can be provided in the standard envelope without decreasing the rod bearing and piston bearing strengths.

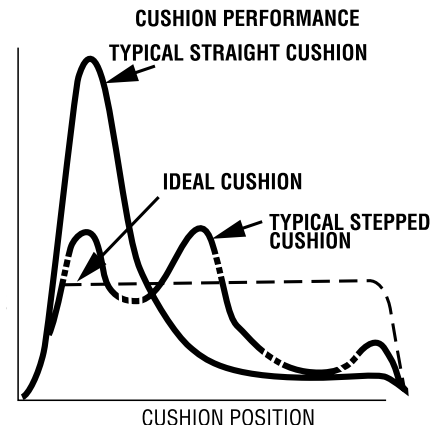

Adjustable Floating Stepped Cushions – For maximum performance – economical and flexible for even the most demanding applications – provides superior performance in reducing shock. Cushions are optional and can be supplied at head end, cap end, or both ends without change in envelope or mounting dimensions.

Steel Cap – Bored and grooved to provide concentricity for mating parts.

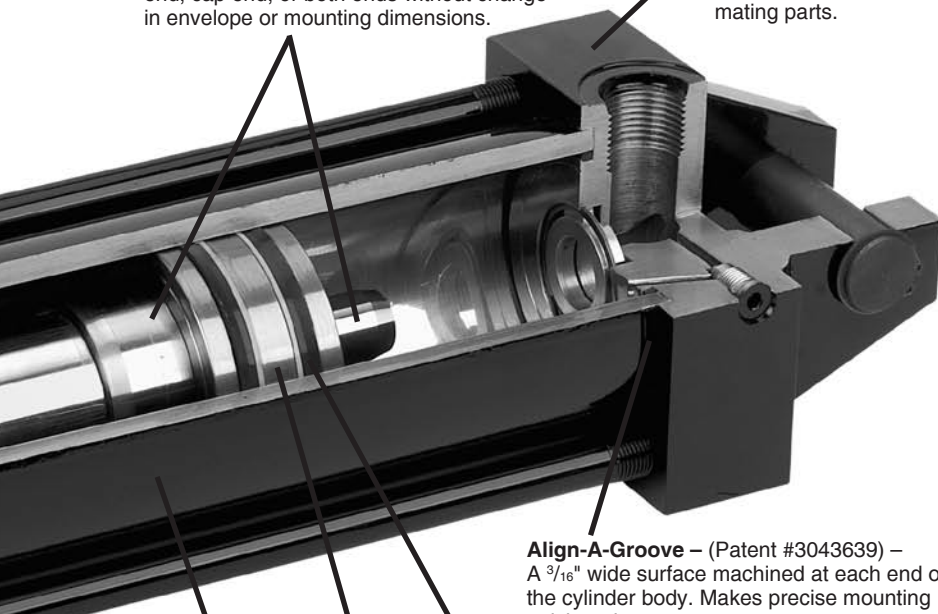

Cylinder Body – Heavy-wall steel tubing, honed to a micro finish bore.

Align-A-Groove – (Patent #3043639) – A $\frac{3}{16}$ " wide surface machined at each end of the cylinder body. Makes precise mounting quick and easy.

Lipseal® Piston – Zero leakage under static conditions for hydraulic pressures up to 3000 PSI. Seals are self-compensating to conform to variations in pressure, mechanical deflection, and wear. Back-up washer prevents extrusion.

One-Piece Nodular Iron Piston – The wide piston surface contacting cylinder bore reduces bearing loads. Anaerobic adhesive is used to permanently lock and seal the piston to the rod.

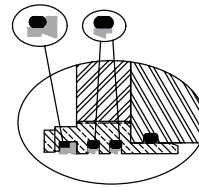

Optional High Temperature Gland – Dual filled PTFE rod seals and filled PTFE wiper seal are energized with fluorocarbon o-rings to maintain consistent contact with the piston rod. Excellent sealing performance produce dry rod on extend stroke with rod scraping to clean rod on retract. Combine with Spring Loaded PTFE Piston Seals for cylinder heat resistance to 400° F. See class 8 seal specification on Operating Fluids and Temperature Range page.

Optional Pistons

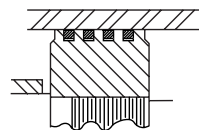

Step cut iron piston rings are optional at no extra charge.

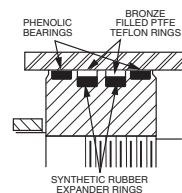

Hi Load Piston – Optional at extra charge. Includes wear rings and bronze-filled PTFE seals. Two wear rings serve as bearings which deform radially under side-loading, enabling the load to be spread over a larger area and reduce unit loading. Bronze-filled PTFE seals are designed for extrusion-free, leak-proof service and longer cylinder life than the lipseal type piston.

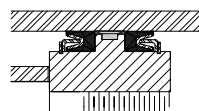

Spring Loaded PTFE Piston Seals

Optional filled PTFE piston Lipseals utilize an internal stainless steel spring to energize both the dynamic and static sealing lips to optimize seal performance throughout the operating temperature range. Non-metallic piston wear ring in 1.50"-6.00" bores (bronze in 7.00" & 8.00" bore 3H) reduces possibility of damaging piston which can score expensive tubing. Combine with High Temperature Gland for cylinder heat resistance to 400° F. See class 8 seal specification on Operating Fluids and Temperature Range page.

(1) When a cushion is specified at the head end:

- a. A self-centering stepped sleeve is furnished on the piston rod assembly.
- b. A needle valve is provided that is flush with the side of the head even when wide open. It may be identified by the fact that it is socket-keyed. It is located on side number 2, in all mounting styles except D, DB, DD, DE, JJ, and HH. In these styles it is located on side number 3.
- c. On 6.00" bore and larger cylinders a springless check valve is provided that is also flush with the side of the head and is mounted adjacent to the needle valve except on mounting style C, where it is mounted opposite the needle valve. It may be identified by the fact that it is slotted.
- d. On 1.50" - 5.00" bore cylinders a slotted sleeve design is used in place of the check valve.

e. 1.50" - 2.50" bore cylinders use a cartridge style needle valve (see Figure A).

(2) When a cushion is specified at the cap end:

- a. A stepped cushion spear is provided on the piston rod.
- b. A "float check" self-centering bushing is provided which incorporates a large flow check valve for fast "out-stroke" action.
- c. A socket-keyed needle valve is provided that is flush with the side of the cap when wide open. It is located on side number 2 in all mounting styles except D, DB, DD, DE, JJ, and HH. In these styles it is located on side number 3.

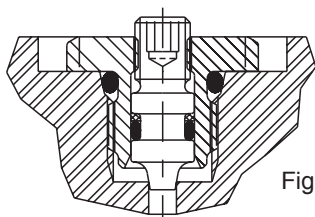
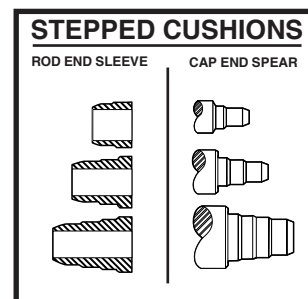

Figure A



Application Checklist

The following checklist should be used to select the best possible cylinder for a given application. Additional information can be referenced in the following pages to help assist in this process. In the event that you have additional questions or concerns, or if more information is required, please contact your local Parker distributor or our customer service representatives for assistance.

- 1. Establish the system requirements** Series 2H
 - How heavy is the load to be moved?
 - What is the nominal operating pressure of the system?
 - How far does the load have to move?
 - What is the speed at which the load will move?
 - What is the fluid type and the temperature to which the cylinder will be exposed?

- 2. Mounting Style** [Page 7](#)
 - Determine the best mounting style for the application.

- 3. Cylinder Bore and Operating Pressure** [Page 96](#)
 - Review the theoretical push and pull force for a given bore size to determine.

- 4. Piston Rod** [Page 104](#)
 - Determine what rod size will be required to avoid buckling.
 - Determine if a single or double rod cylinder is required.
 - Determine the rod end style and rod end thread.
 - Will stop tubing be required?

- 5. Piston Seals** [Page 99](#)
 - Determine the best seal type for your application.
 - Select the proper seal type and configuration for the application.
 - Select the proper seal to assure fluid and temperature compatibility.

- 6. Cushioning** [Page 106](#)
 - Determine if cushions are required to safely stop the load.

- 7. Ports** [Page 101](#)
 - Select the best possible port size for a given speed requirement.
 - Select port position.

- 8. Piston rod and mounting accessories** [Page 66](#)
 - Determine how you will attach the cylinder to the load.

- 9. Optional accessories and modifications** [Page 65](#)

Mounting Styles & Tips for Applying Them

Extended Tie Rod Mountings – TB, TC, and TD

Application:

- Straight line force transfer
- Compression loads (push)
– use TC or TD
- Tension loads (pull)
– use TB or TD

Advantages:

- Ease of mounting in tight spaces
- Force is transferred along the centerline of the cylinder

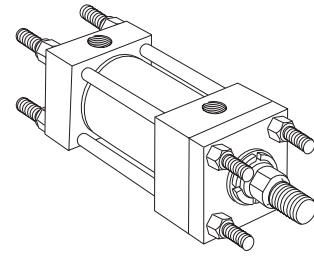

Flange Mountings – J, JB, JJ, H, HB, and HH

Application:

- Straight line force transfer
- Compression loads (push)
– use H, HB or HH
- Tension loads (pull)
– use J, JB, or JJ

Advantages:

- Rigid base mounting due to large flange area
- Force is transferred along the centerline of the cylinder

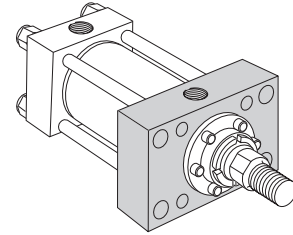

Side Tap Mounting – F / Side Lug Mounting – C

Application:

- Straight line force transfer
- Can be used in compression or tension loads
- Thrust key and secure mounting area are vital

Advantages:

- Ease of mounting

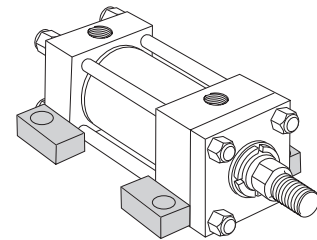

Pivot Mountings – BB and SB

Application:

- Curved or arc line force transfer
- Can be used in compression or tension loads
- Movement in a simple arc
– use BB mountings
- Movement in a compound arc
– use SB mountings

Advantages:

- Ease of mounting
- Design flexibility
- Self aligning (SB)

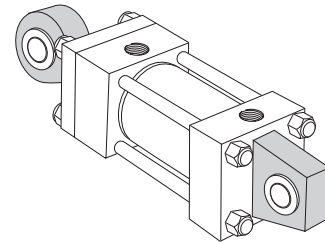

Trunnion Mountings – D, DB, DD and DE

Application:

- Curved or arc line force transfer
- Can be used in compression or tension loads
- Compression loads – use DB or DD, DE mountings
- Tension loads – use D, DD or DE mountings

Advantages:

- Ease of mounting
- Design flexibility
- Self aligning

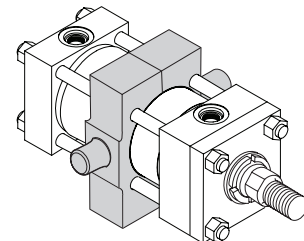

2H Model Code

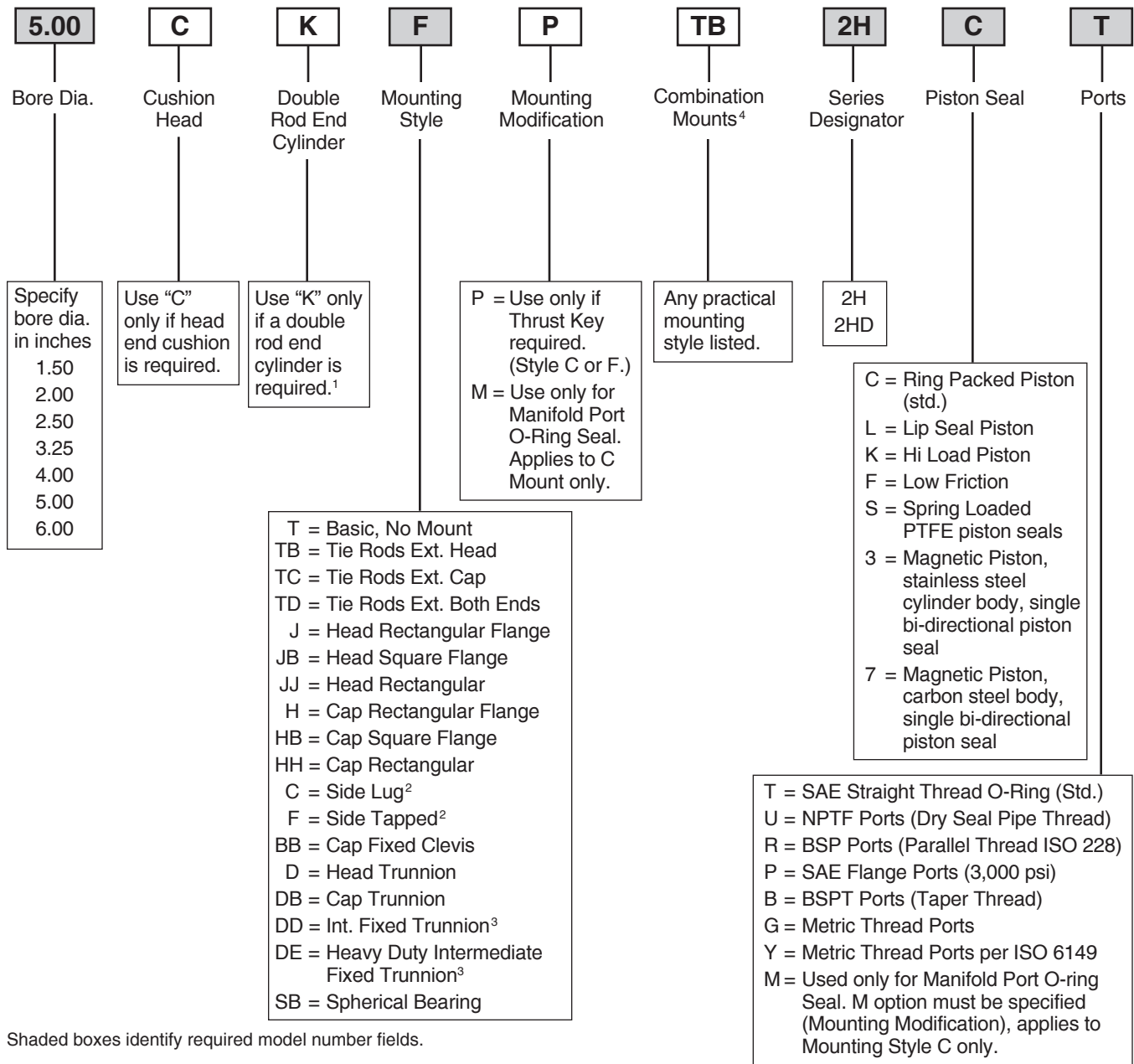

Shaded boxes identify required model number fields.

¹ Available mounting styles for K Type cylinders are located at the end of Section A. When ordering a double rod end cylinder, the piston rod number and piston rod end threads are to be specified for both rod ends.

The model number should be created as viewing the primary rod end on the left hand side.

Example: K Type Cylinder:
4.00CKTD2HLT14A28AC10.000

² Mounting Styles C and F should have a minimum stroke length equal to or greater than their bore size.

³ Specify XI dimension.

⁴ In general, the model numbers as read left to right corresponding to the cylinder as viewed from left to right with the primary end at the left. The second or subsequent mountings are mountings called out as they appear in the assembly moving away from the rod end. Except when tie rod extension mountings are part of a combination, all combinations should have a "S" (Special) in the model code and a note in the body of the order clarifying the mounting arrangement. The "P", as used to define a thrust key is not considered to be a mounting. However it is located at the primary end.



How To Order

2H Model Code

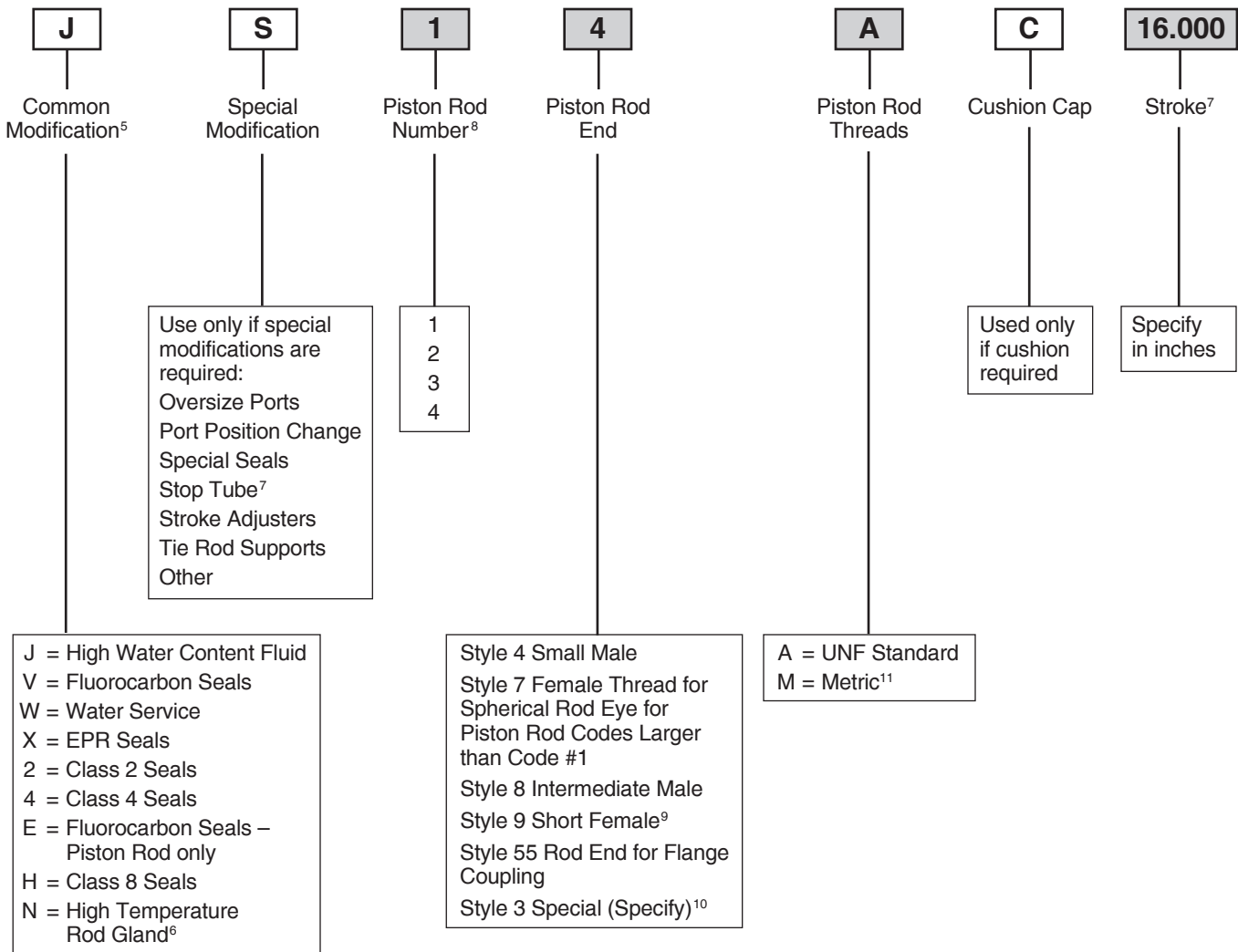

Shaded boxes identify required model number fields.

⁵ See common modifications Section D for additional options.

⁶ Energized PTFE rod seals & wiperseal. All other cylinder seals are fluorocarbon.

⁷ S = Stop Tube. Specify: stop tube length, net stroke and gross stroke. Gross stroke = stop tube length + net stroke. Gross stroke to be placed in the model number field.
Example:
2.000 inches long stop tube
+14.000 inches net stroke
16.000 inches gross stroke

⁸ Refer to Rod buckling chart in Section E to assure rod number selected will not buckle under load.

⁹ Style 9 stroke restrictions may apply. See Style 9 Minimum Stroke Table for details.

¹⁰ Provide dimensions for KK, A, W or WF. If otherwise special, furnish dimensioned sketch.

¹¹ See Section D for detailed information regarding standard metric rod end thread sizes.

Style 9 Minimum Stroke Table

Bore Ø	Rod Ø	Minimum Stroke
1.50 - 4.00	All	None
5.00	2.000	None
	2.500	1.000
	3.000	1.375
	3.500	1.625
6.00	2.500	None
	3.000	1.375
	3.500	1.375
	4.000	2.000

Rod End Dimensions

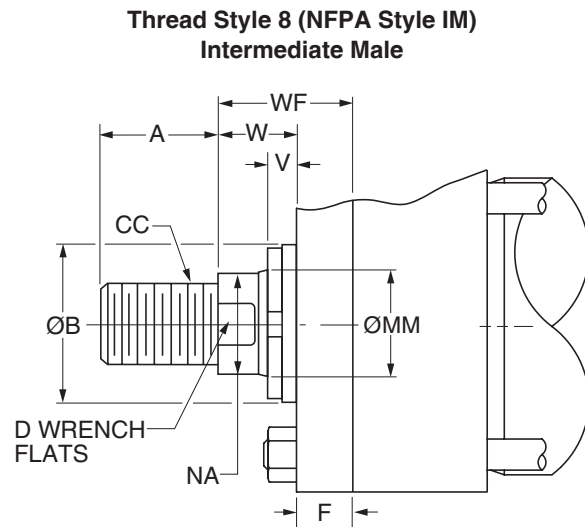
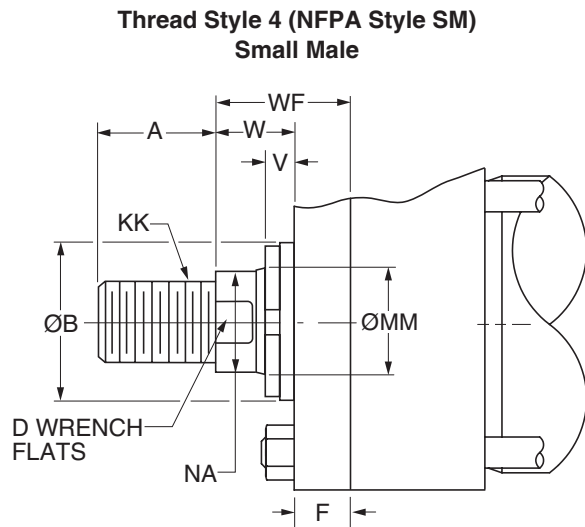

Rod End Dimensions

Bore Ø	Rod No.	MM Rod Ø	Thread		A	B Ø +0.000 -0.002	D	F	NA	V	W	WF
			Style 8 CC	Style 4 KK								
1.50	1 (Std.)	0.625	1/2-20	7/16-20	0.75	1.124	0.50	0.38	0.56	0.25	0.63	1.00
	2	1.000	7/8-14	3/4-16	1.13	1.499	0.88	0.38	0.94	0.50	1.00	1.38
2.00	1 (Std.)	1.000	7/8-14	3/4-16	1.13	1.499	0.88	0.63	0.94	0.25	0.75	1.38
	2	1.375	1 1/4-12	1-14	1.63	1.999	1.13	0.63	1.31	0.38	1.00	1.63
2.50	1 (Std.)	1.000	7/8-14	3/4-16	1.13	1.499	0.88	0.63	0.94	0.25	0.75	1.38
	2	1.750	1 1/2-12	1 1/4-12	2.00	2.374	1.50	0.63	1.69	0.50	1.25	1.88
	3	1.375	1 1/4-12	1-14	1.63	1.999	1.13	0.63	1.31	0.38	1.00	1.63
3.25	1 (Std.)	1.375	1 1/4-12	1-14	1.63	1.999	1.13	0.75	1.31	0.25	0.88	1.63
	2	2.000	1 3/4-12	1 1/2-12	2.25	2.624	1.69	0.75	1.94	0.38	1.25	2.00
	3	1.750	1 1/2-12	1 1/4-12	2.00	2.374	1.50	0.75	1.69	0.38	1.13	1.88
4.00	1 (Std.)	1.750	1 1/2-12	1 1/4-12	2.00	2.374	1.50	0.88	1.69	0.25	1.00	1.88
	2	2.500	2 1/4-12	1 7/8-12	3.00	3.124	2.06	0.88	2.38	0.38	1.38	2.25
	3	2.000	1 3/4-12	1 1/2-12	2.25	2.624	1.69	0.88	1.94	0.25	1.13	2.00
5.00	1 (Std.)	2.000	1 3/4-12	1 1/2-12	2.25	2.624	1.69	0.88	1.94	0.25	1.13	2.00
	2	3.500	3 1/4-12	2 1/2-12	3.50	4.249	3.00	0.88	3.38	0.38	1.38	2.25
	3	2.500	2 1/4-12	1 7/8-12	3.00	3.124	2.06	0.88	2.38	0.38	1.38	2.25
	4	3.000	2 3/4-12	2 1/4-12	3.50	3.749	2.63	0.88	2.88	0.38	1.38	2.25
6.00	1 (Std.)	2.500	2 1/4-12	1 7/8-12	3.00	3.124	2.06	1.00	2.38	0.25	1.25	2.25
	2	4.000	3 3/4-12	3-12	4.00	4.749	3.38	1.00	3.88	0.25	1.25	2.25
	3	3.000	2 3/4-12	2 1/4-12	3.50	3.749	2.63	1.00	2.88	0.25	1.25	2.25
	4	3.500	3 1/4-12	2 1/2-12	3.50	4.249	3.00	1.00	3.38	0.25	1.25	2.25

“Special” Thread Style 3

Special thread, extension, rod eye, blank, etc., are also available.

To order, specify “Style 3” and give desired dimensions for KK, A, W or WF.
 If otherwise special, furnish dimensioned sketch.

Rod End Dimensions

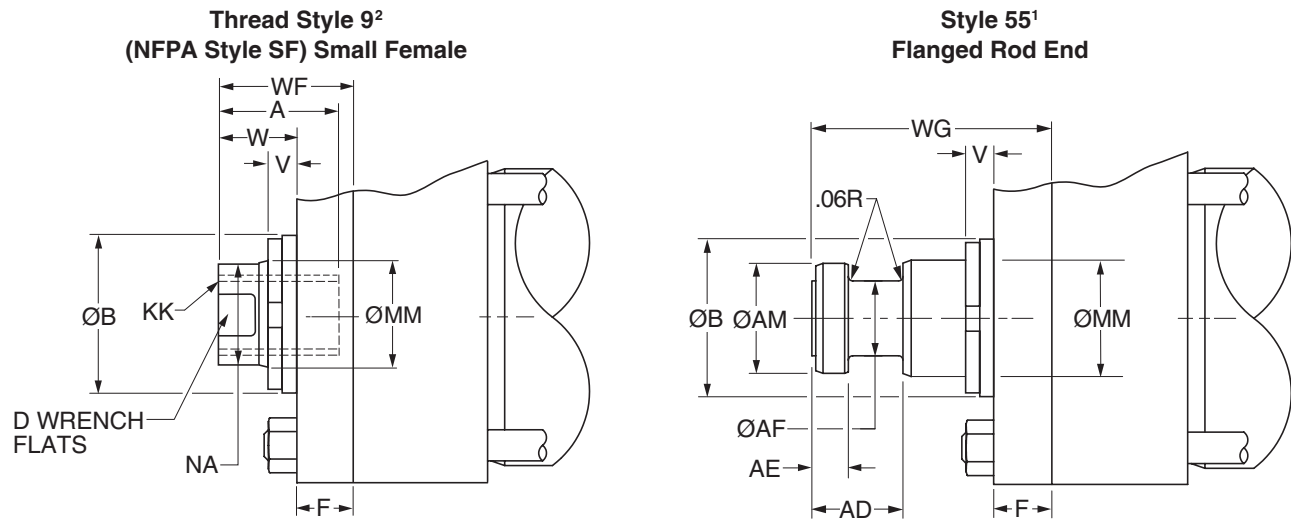

Rod End Dimensions

Bore Ø	Rod No.	MM Rod Ø	Thread	A	AD	AE +.001 -.001	AF Ø	AM Ø	B Ø +.000 -.002	D	F	NA	V	W	WF	WG
			Style 9 KK													
1.50	1 (Std.)	0.625	7/16-20	0.75	0.63	0.249	0.38	0.57	1.124	0.50	0.38	0.56	0.25	0.63	1.00	1.75
	2	1.000	3/4-16	1.13	0.94	0.374	0.69	0.95	1.499	0.88	0.38	0.94	0.50	1.00	1.38	2.38
2.00	1 (Std.)	1.000	3/4-16	1.13	0.94	0.374	0.69	0.95	1.499	0.88	0.63	0.94	0.25	0.75	1.38	2.38
	2	1.375	1-14	1.63	1.06	0.374	0.88	1.32	1.999	1.13	0.63	1.31	0.38	1.00	1.63	2.75
2.50	1 (Std.)	1.000	3/4-16	1.13	0.94	0.374	0.69	0.95	1.499	0.88	0.63	0.94	0.25	0.75	1.38	2.38
	2	1.750	1 1/4-12	2.00	1.31	0.499	1.13	1.70	2.374	1.50	0.63	1.69	0.50	1.25	1.88	3.13
	3	1.375	1-14	1.63	1.06	0.374	0.88	1.32	1.999	1.13	0.63	1.31	0.38	1.00	1.63	2.75
3.25	1 (Std.)	1.375	1-14	1.63	1.06	0.374	0.88	1.32	1.999	1.13	0.75	1.31	0.25	0.88	1.63	2.75
	2	2.000	1 1/2-12	2.25	1.69	0.624	1.38	1.95	2.624	1.69	0.75	1.94	0.38	1.25	2.00	3.75
	3	1.750	1 1/4-12	2.00	1.31	0.499	1.13	1.70	2.374	1.50	0.75	1.69	0.38	1.13	1.88	3.13
4.00	1 (Std.)	1.750	1 1/4-12	2.00	1.31	0.499	1.13	1.70	2.374	1.50	0.88	1.69	0.25	1.00	1.88	3.13
	2	2.500	1 7/8-12	3.00	1.94	0.749	1.75	2.45	3.124	2.06	0.88	2.38	0.38	1.38	2.25	4.50
	3	2.000	1 1/2-12	2.25	1.69	0.624	1.38	1.95	2.624	1.69	0.88	1.94	0.25	1.13	2.00	3.75
5.00	1 (Std.)	2.000	1 1/2-12	2.25	1.69	0.624	1.38	1.95	2.624	1.69	0.88	1.94	0.25	1.13	2.00	3.75
	2	3.500	2 1/2-12	3.50	2.69	0.999	2.50	3.45	4.249	3.00	0.88	3.38	0.38	1.38	2.25	5.63
	3	2.500	1 7/8-12	3.00	1.94	0.749	1.75	2.45	3.124	2.06	0.88	2.38	0.38	1.38	2.25	4.50
	4	3.000	2 1/4-12	3.50	2.44	0.874	2.25	2.95	3.749	2.63	0.88	2.88	0.38	1.38	2.25	4.88
6.00	1 (Std.)	2.500	1 7/8-12	3.00	1.94	0.749	1.75	2.45	3.124	2.06	1.00	2.38	0.25	1.25	2.25	4.50
	2	4.000	3-12	4.00	2.69	0.999	3.00	3.95	4.749	3.38	1.00	3.88	0.25	1.25	2.25	5.75
	3	3.000	2 1/4-12	3.50	2.44	0.874	2.25	2.95	3.749	2.63	1.00	2.88	0.25	1.25	2.25	4.88
	4	3.500	2 1/2-12	3.50	2.69	0.999	2.50	3.45	4.249	3.00	1.00	3.38	0.25	1.25	2.25	5.63

“Special” Thread Style 3

Special thread, extension, rod eye, blank, etc., are also available.

To order, specify “Style 3” and give desired dimensions for KK, A, W or WF. If otherwise special, furnish dimensioned sketch.

¹ For special WG dimension, specify “Style 3” and give desired dimension for WG. For other changes, place “S” in the model code, and describe rod end with dimensioned sketch.

² Style 9 stroke restrictions may apply. See Style 9 Minimum Stroke Table on How to Order page for details.



Mounting Information – 1.50" to 6.00" Bore

Tie Rods Extended Both Ends Mounting
Style TD
(NFA Style MX1)

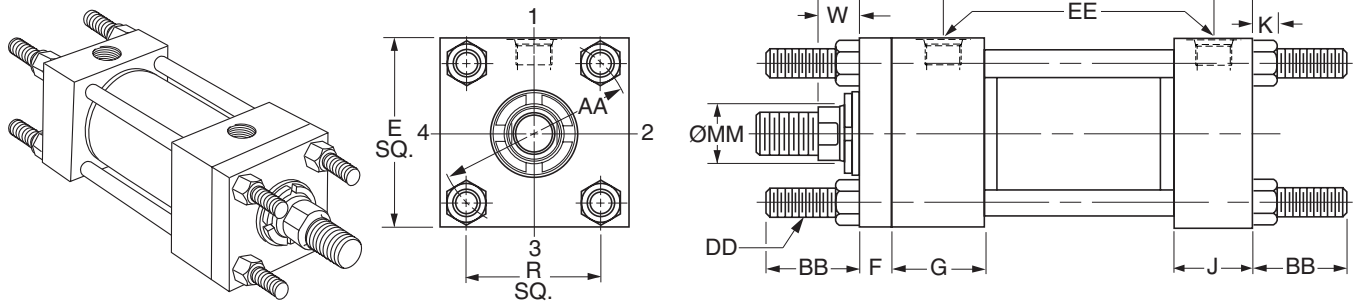

Table 1 – Dimensional and Mounting Data

Bore Ø	Rod No.	MM Rod Ø	AA	BB	DD	E	EE		F	G	J	K	R	W	Y	Add Stroke		
							NPTF ¹	SAE ²								LB	P	ZJ
1.50	1 (std.)	0.625	2.31	1.38	3/8-24	2.50	1/2	10	0.38	1.75	1.50	0.38	1.63	0.63	2.00	5.00	2.88	5.63
	2	1.000	2.31	1.38	3/8-24	2.50	1/2	10	0.38	1.75	1.50	0.38	1.63	1.00	2.38	5.00	2.88	6.00
2.00	1 (std.)	1.000	2.90	1.81	1/2-20	3.00	1/2	10	0.63	1.75	1.50	0.44	2.05	0.75	2.38	5.25	2.88	6.00
	2	1.375	2.90	1.81	1/2-20	3.00	1/2	10	0.63	1.75	1.50	0.44	2.05	1.00	2.63	5.25	2.88	6.25
2.50	1 (std.)	1.000	3.61	1.81	1/2-20	3.50	1/2	10	0.63	1.75	1.50	0.44	2.55	0.75	2.38	5.38	3.00	6.13
	2	1.750	3.61	1.81	1/2-20	3.50	1/2	10	0.63	1.75	1.50	0.44	2.55	1.25	2.88	5.38	3.00	6.63
	3	1.375	3.61	1.81	1/2-20	3.50	1/2	10	0.63	1.75	1.50	0.44	2.55	1.00	2.63	5.38	3.00	6.38
3.25	1 (std.)	1.375	4.60	2.31	5/8-18	4.50	3/4	12	0.75	2.00	1.75	0.56	3.25	0.88	2.75	6.25	3.50	7.13
	2	2.000	4.60	2.31	5/8-18	4.50	3/4	12	0.75	2.00	1.75	0.56	3.25	1.25	3.13	6.25	3.50	7.50
	3	1.750	4.60	2.31	5/8-18	4.50	3/4	12	0.75	2.00	1.75	0.56	3.25	1.13	3.00	6.25	3.50	7.38
4.00	1 (std.)	1.750	5.40	2.31	5/8-18	5.00	3/4	12	0.88	2.00	1.75	0.56	3.82	1.00	3.00	6.63	3.75	7.63
	2	2.500	5.40	2.31	5/8-18	5.00	3/4	12	0.88	2.00	1.75	0.56	3.82	1.38	3.38	6.63	3.75	8.00
	3	2.000	5.40	2.31	5/8-18	5.00	3/4	12	0.88	2.00	1.75	0.56	3.82	1.13	3.13	6.63	3.75	7.75
5.00	1 (std.)	2.000	7.00	3.19	7/8-14	6.50	3/4	12	0.88	2.00	1.75	0.81	4.95	1.13	3.13	7.13	4.25	8.25
	2	3.500	7.00	3.19	7/8-14	6.50	3/4	12	0.88	2.00	1.75	0.81	4.95	1.38	3.38	7.13	4.25	8.50
	3	2.500	7.00	3.19	7/8-14	6.50	3/4	12	0.88	2.00	1.75	0.81	4.95	1.38	3.38	7.13	4.25	8.50
	4	3.000	7.00	3.19	7/8-14	6.50	3/4	12	0.88	2.00	1.75	0.81	4.95	1.38	3.38	7.13	4.25	8.50
6.00	1 (std.)	2.500	8.10	3.63	1-14	7.50	1	16	1.00	2.25	2.25	0.88	5.73	1.25	3.50	8.38	4.88	9.63
	2	4.000	8.10	3.63	1-14	7.50	1	16	1.00	2.25	2.25	0.88	5.73	1.25	3.50	8.38	4.88	9.63
	3	3.000	8.10	3.63	1-14	7.50	1	16	1.00	2.25	2.25	0.88	5.73	1.25	3.50	8.38	4.88	9.63
	4	3.500	8.10	3.63	1-14	7.50	1	16	1.00	2.25	2.25	0.88	5.73	1.25	3.50	8.38	4.88	9.63

¹NPTF ports are available at no extra charge.

²SAE straight thread ports are standard and are indicated by port number.

Style T

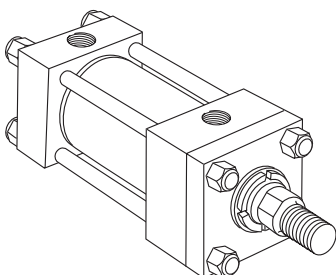

Style TB

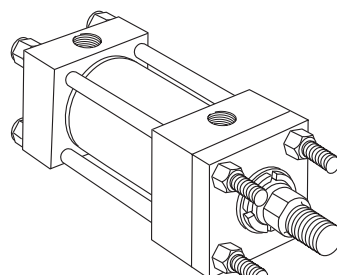

Style TC

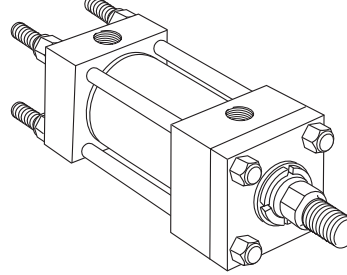

Dimensions for T, TB and TC Mount may be obtained from the above dimensional table.

Mounting Information – 1.50" to 6.00" Bore Series 2H

Head Rectangular Flange Mounting
Style J
(NFPA Style MF1)

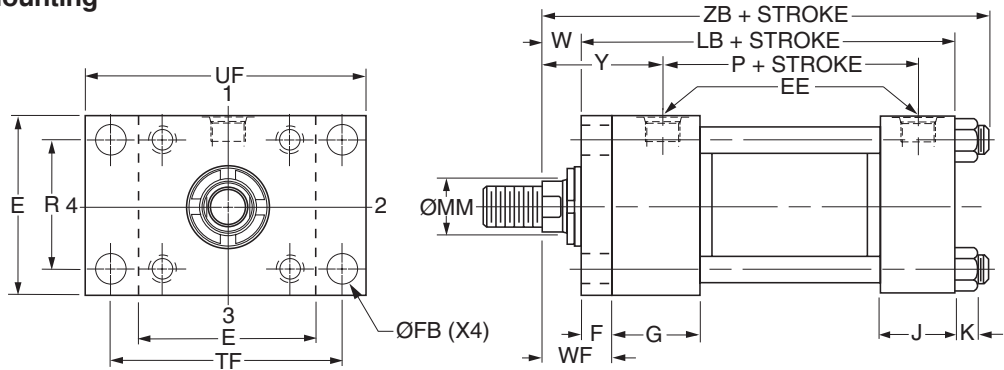
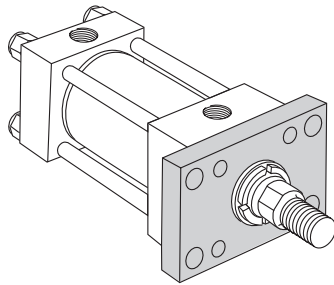

Table 1 – Dimensional and Mounting Data

Bore Ø	E	EE		F	FB Ø	G	J	K	R	TF	UF	Add Stroke	
		NPTF ¹	SAE ²									LB	P
1.50	2.50	1/2	10	0.38	0.44	1.75	1.50	0.38	1.63	3.44	4.25	5.00	2.88
2.00	3.00	1/2	10	0.63	0.56	1.75	1.50	0.44	2.05	4.13	5.13	5.25	2.88
2.50	3.50	1/2	10	0.63	0.56	1.75	1.50	0.44	2.55	4.63	5.63	5.38	3.00
3.25	4.50	3/4	12	0.75	0.69	2.00	1.75	0.56	3.25	5.88	7.13	6.25	3.50
4.00	5.00	3/4	12	0.88	0.69	2.00	1.75	0.56	3.82	6.38	7.63	6.63	3.75
5.00	6.50	3/4	12	0.88	0.94	2.00	1.75	0.81	4.95	8.19	9.75	7.13	4.25
6.00	7.50	1	16	1.00	1.06	2.25	2.25	0.88	5.73	9.44	11.25	8.38	4.88

¹NPTF ports are available at no extra charge.

²SAE straight thread ports are standard and are indicated by port number.

Table 2 – Dimensional and Mounting Data

Bore Ø	Rod No.	MM Rod Ø	W	WF	Y	Add Stroke
						ZB Max.
1.50	1 (std.)	0.625	0.63	1.00	2.00	6.25
	2	1.000	1.00	1.38	2.38	6.63
2.00	1 (std.)	1.000	0.75	1.38	2.38	6.69
	2	1.375	1.00	1.63	2.63	6.94
2.50	1 (std.)	1.000	0.75	1.38	2.38	6.81
	2	1.750	1.25	1.88	2.88	7.31
	3	1.375	1.00	1.63	2.63	7.06
3.25	1 (std.)	1.375	0.88	1.63	2.75	7.94
	2	2.000	1.25	2.00	3.13	8.31
	3	1.750	1.13	1.88	3.00	8.19
4.00	1 (std.)	1.750	1.00	1.88	3.00	8.50
	2	2.500	1.38	2.25	3.38	8.88
	3	2.000	1.13	2.00	3.13	8.63
5.00	1 (std.)	2.000	1.13	2.00	3.13	9.38
	2	3.500	1.38	2.25	3.38	9.63
	3	2.500	1.38	2.25	3.38	9.63
	4	3.000	1.38	2.25	3.38	9.63
6.00	1 (std.)	2.500	1.25	2.25	3.50	10.81
	2	4.000	1.25	2.25	3.50	10.81
	3	3.000	1.25	2.25	3.50	10.81
	4	3.500	1.25	2.25	3.50	10.81

Table 3 – Maximum Operating Pressure - 2H

Bore Ø	Maximum psi Push ³			
	Rod Code			
	1	2	3	4
1.50	1500	1000	-	-
2.00	2000	1200	-	-
2.50	2000	1100	1500	-
3.25	1800	1300	1400	-
4.00	1800	1300	1700	-
5.00	1300	800	1200	1000
6.00	1200	800	1000	900

Table 4 – Maximum Operating Pressure - 2HD

Bore Ø	Maximum psi Push ³			
	Rod Code			
	1	2	3	4
1.50	1400	1000	-	-
2.00	2000	1200	-	-
2.50	700	1000	700	-
3.25	800	600	800	-
4.00	1000	700	1000	-
5.00	850	800	850	450
6.00	650	400	650	400

³Maximum Pressure Rating – Push Application.



Mounting Information – 1.50" to 6.00" Bore Series 2H

Head Square Flange Mounting
Style JB
(NFPA Style MF5)

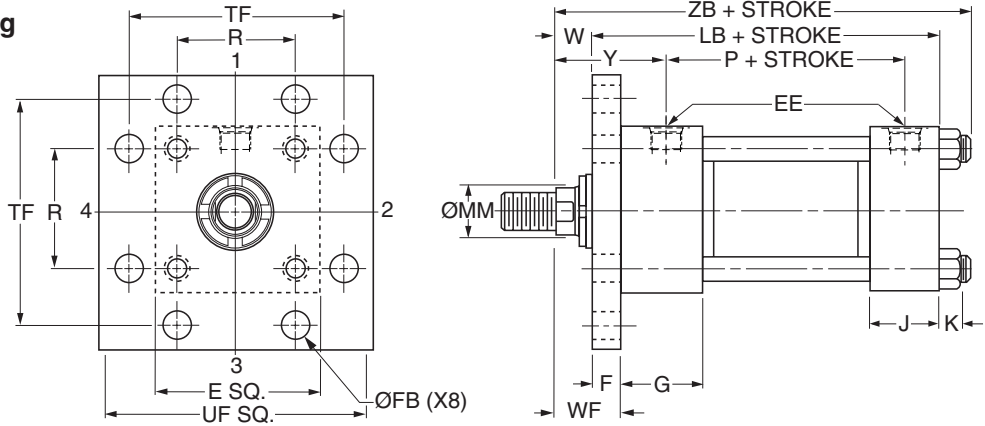
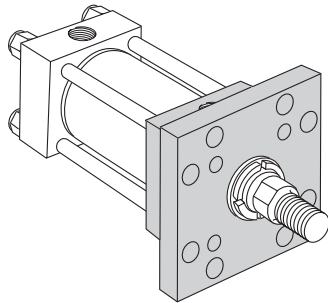

Table 1 – Dimensional and Mounting Data

Bore Ø	E	EE		F	FB Ø	G	J	K	R	TF	UF	Add Stroke	
		NPTF ¹	SAE ²									LB	P
1.50	2.50	1/2	10	0.38	0.44	1.75	1.50	0.38	1.63	3.44	4.25	5.00	2.88
2.00	3.00	1/2	10	0.63	0.56	1.75	1.50	0.44	2.05	4.13	5.13	5.25	2.88
2.50	3.50	1/2	10	0.63	0.56	1.75	1.50	0.44	2.55	4.63	5.63	5.38	3.00
3.25	4.50	3/4	12	0.75	0.69	2.00	1.75	0.56	3.25	5.88	7.13	6.25	3.50
4.00	5.00	3/4	12	0.88	0.69	2.00	1.75	0.56	3.82	6.38	7.63	6.63	3.75
5.00	6.50	3/4	12	0.88	0.94	2.00	1.75	0.81	4.95	8.19	9.75	7.13	4.25
6.00	7.50	1	16	1.00	1.06	2.25	2.25	0.88	5.73	9.44	11.25	8.38	4.88

¹NPTF ports are available at no extra charge.

²SAE straight thread ports are standard and are indicated by port number.

Table 2 – Dimensional and Mounting Data

Bore Ø	Rod No.	MM Rod Ø	W	WF	Y	Add Stroke
						ZB Max.
1.50	1 (std.)	0.625	0.63	1.00	2.00	6.25
	2	1.000	1.00	1.38	2.38	6.63
2.00	1 (std.)	1.000	0.75	1.38	2.38	6.69
	2	1.375	1.00	1.63	2.63	6.94
2.50	1 (std.)	1.000	0.75	1.38	2.38	6.81
	2	1.750	1.25	1.88	2.88	7.31
	3	1.375	1.00	1.63	2.63	7.06
3.25	1 (std.)	1.375	0.88	1.63	2.75	7.94
	2	2.000	1.25	2.00	3.13	8.31
	3	1.750	1.13	1.88	3.00	8.19
4.00	1 (std.)	1.750	1.00	1.88	3.00	8.50
	2	2.500	1.38	2.25	3.38	8.88
	3	2.000	1.13	2.00	3.13	8.63
5.00	1 (std.)	2.000	1.13	2.00	3.13	9.38
	2	3.500	1.38	2.25	3.38	9.63
	3	2.500	1.38	2.25	3.38	9.63
	4	3.000	1.38	2.25	3.38	9.63
6.00	1 (std.)	2.500	1.25	2.25	3.50	10.81
	2	4.000	1.25	2.25	3.50	10.81
	3	3.000	1.25	2.25	3.50	10.81
	4	3.500	1.25	2.25	3.50	10.81

Table 3 – Maximum Operating Pressure - 2H

Bore Ø	Maximum psi Push ³			
	Rod Code			
	1	2	3	4
1.50	3000	3000	-	-
2.00	3000	3000	-	-
2.50	3000	3000	3000	-
3.25	3000	3000	3000	-
4.00	3000	3000	3000	-
5.00	3000	3000	3000	3000
6.00	3000	2700	3000	2700

³Maximum Pressure Rating – Push Application.

Table 4 – Maximum Operating Pressure - 2HD

Bore Ø	Maximum psi Push ³			
	Rod Code			
	1	2	3	4
1.50	3000	3000	-	-
2.00	3000	3000	-	-
2.50	3000	3000	3000	-
3.25	3000	3000	3000	-
4.00	3000	3000	3000	-
5.00	2500	2300	2500	1800
6.00	2000	1600	2000	1600

Mounting Information – 1.50" to 6.00" Bore Series 2H

Head Rectangular Mounting
Style JJ
(NFPA Style ME5)

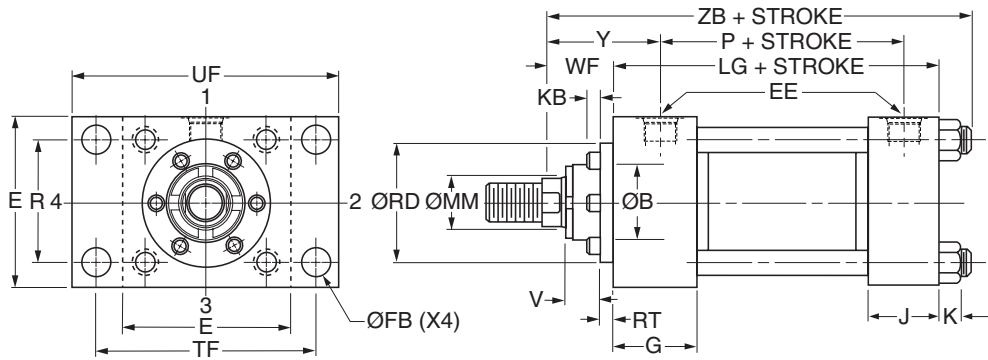
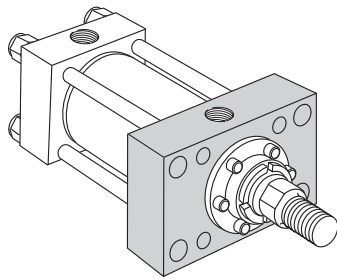

Table 1 – Dimensional and Mounting Data

Bore Ø	E	EE		FB Ø	G	J	K	R	TF	UF	Add Stroke	
		NPTF ¹	SAE ²								LG	P
1.50	2.50	1/2	10	0.44	1.75	1.50	0.38	1.63	3.44	4.25	4.63	2.88
2.00	3.00	1/2	10	0.56	1.75	1.50	0.44	2.05	4.13	5.13	4.63	2.88
2.50	3.50	1/2	10	0.56	1.75	1.50	0.44	2.55	4.63	5.63	4.75	3.00
3.25	4.50	3/4	12	0.69	2.00	1.75	0.56	3.25	5.88	7.13	5.50	3.50
4.00	5.00	3/4	12	0.69	2.00	1.75	0.56	3.82	6.38	7.63	5.75	3.75
5.00	6.50	3/4	12	0.94	2.00	1.75	0.81	4.95	8.19	9.75	6.25	4.25
6.00	7.50	1	16	1.06	2.25	2.25	0.88	5.73	9.44	11.25	7.38	4.88

¹NPTF ports are available at no extra charge.

²SAE straight thread ports are standard and are indicated by port number.

Table 2 – Dimensional and Mounting Data

Bore Ø	Rod No.	MM Rod Ø	B Ø +.000 -0.002	KB	RD Ø	RT	V	WF	Y	Add Stroke
										ZB Max
1.50	1 (std.)	0.625	1.124	-	2.13	0.38	0.25	1.00	2.00	6.25
	2	1.000	1.499	-	2.50	0.38	0.50	1.38	2.38	6.63
2.00	1 (std.)	1.000	1.499	-	2.50	0.38	0.50	1.38	2.38	6.69
	2	1.375	1.999	.25	3.00	0.38	0.63	1.63	2.63	6.94
2.50	1 (std.)	1.000	1.499	-	2.50	0.38	0.50	1.38	2.38	6.81
	2	1.750	2.374	.25	3.50	0.38	0.75	1.88	2.88	7.31
	3	1.375	1.999	.25	3.00	0.38	0.63	1.63	2.63	7.06
3.25	1 (std.)	1.375	1.999	.25	3.00	0.38	0.63	1.63	2.75	7.94
	2	2.000	2.624	.13	4.00	0.63	0.50	2.00	3.13	8.31
	3	1.750	2.374	.25	3.50	0.38	0.75	1.88	3.00	8.19
4.00	1 (std.)	1.750	2.374	.25	3.50	0.38	0.75	1.88	3.00	8.50
	2	2.500	3.124	.25	4.50	0.63	0.63	2.25	3.38	8.88
	3	2.000	2.624	.13	4.00	0.63	0.50	2.00	3.13	8.63
5.00	1 (std.)	2.000	2.624	.13	4.00	0.63	0.50	2.00	3.13	9.38
	2	3.500	4.249	.25	5.75	0.63	0.63	2.25	3.38	9.63
	3	2.500	3.124	.25	4.50	0.63	0.63	2.25	3.38	9.63
	4	3.000	3.749	.25	5.25	0.63	0.63	2.25	3.38	9.63
6.00	1 (std.)	2.500	3.124	.25	4.50	0.63	0.63	2.25	3.50	10.81
	2	4.000	4.749	.25	6.50	0.75	0.50	2.25	3.50	10.81
	3	3.000	3.749	.25	5.25	0.63	0.63	2.25	3.50	10.81
	4	3.500	4.249	.25	5.75	0.63	0.63	2.25	3.50	10.81



Mounting Information – 1.50" to 6.00" Bore Series 2H

**Cap Rectangular Flange Mounting
Style H
(NFPA Style MF2)**

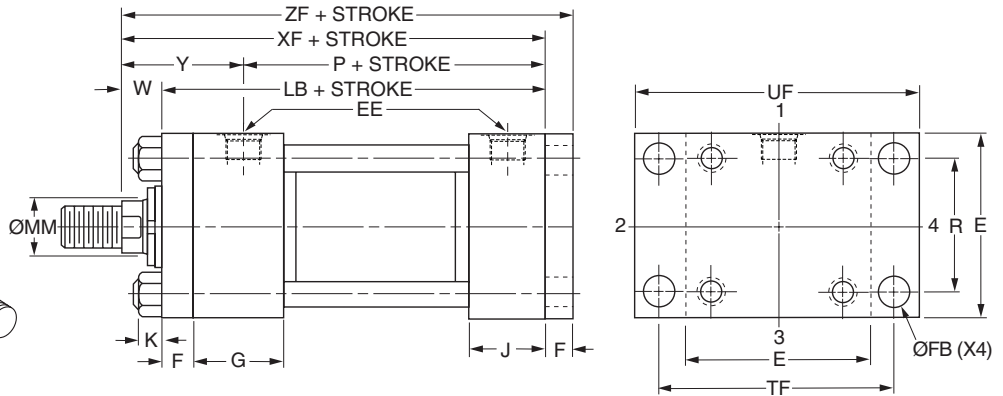
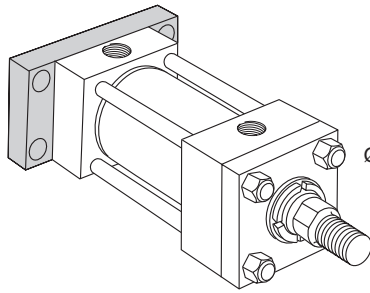

Table 1 – Dimensional and Mounting Data

Bore Ø	E	EE		F	FB Ø	G	J	K	R	TF	UF	Add Stroke	
		NPTF ¹	SAE ²									LB	P
1.50	2.50	1/2	10	0.38	0.44	1.75	1.50	0.38	1.63	3.44	4.25	5.00	2.88
2.00	3.00	1/2	10	0.63	0.56	1.75	1.50	0.44	2.05	4.13	5.13	5.25	2.88
2.50	3.50	1/2	10	0.63	0.56	1.75	1.50	0.44	2.55	4.63	5.63	5.38	3.00
3.25	4.50	3/4	12	0.75	0.69	2.00	1.75	0.56	3.25	5.88	7.13	6.25	3.50
4.00	5.00	3/4	12	0.88	0.69	2.00	1.75	0.56	3.82	6.38	7.63	6.63	3.75
5.00	6.50	3/4	12	0.88	0.94	2.00	1.75	0.81	4.95	8.19	9.75	7.13	4.25
6.00	7.50	1	16	1.00	1.06	2.25	2.25	0.88	5.73	9.44	11.25	8.38	4.88

¹NPTF ports are available at no extra charge.

²SAE straight thread ports are standard and are indicated by port number.

Table 2 – Dimensional and Mounting Data

Bore Ø	Rod No.	MM Rod Ø	W	Y	Add Stroke	
					XF	ZF
1.50	1 (std.)	0.625	0.63	2.00	5.63	6.00
	2	1.000	1.00	2.38	6.00	6.38
2.00	1 (std.)	1.000	0.75	2.38	6.00	6.63
	2	1.375	1.00	2.63	6.25	6.88
2.50	1 (std.)	1.000	0.75	2.38	6.13	6.75
	2	1.750	1.25	2.88	6.63	7.25
	3	1.375	1.00	2.63	6.38	7.00
3.25	1 (std.)	1.375	0.88	2.75	7.13	7.88
	2	2.000	1.25	3.13	7.50	8.25
	3	1.750	1.13	3.00	7.38	8.13
4.00	1 (std.)	1.750	1.00	3.00	7.63	8.50
	2	2.500	1.38	3.38	8.00	8.88
	3	2.000	1.13	3.13	7.75	8.63
5.00	1 (std.)	2.000	1.13	3.13	8.25	9.13
	2	3.500	1.38	3.38	8.50	9.38
	3	2.500	1.38	3.38	8.50	9.38
	4	3.000	1.38	3.38	8.50	9.38
6.00	1 (std.)	2.500	1.25	3.50	9.63	10.63
	2	4.000	1.25	3.50	9.63	10.63
	3	3.000	1.25	3.50	9.63	10.63
	4	3.500	1.25	3.50	9.63	10.63

Table 3 – Maximum Operating Pressure - 2H & 2HD

Bore Ø	Maximum psi Pull ³			
	Rod Code			
	1	2	3	4
1.50	2500	3000	-	-
2.00	3000	3000	-	-
2.50	3000	3000	3000	-
3.25	3000	3000	3000	-
4.00	3000	3000	3000	-
5.00	2000	3000	2000	2500
6.00	1800	2500	2000	2000

³Maximum pressure rating — pull application.

Mounting Information – 1.50" to 6.00" Bore Series 2H

Cap Square Flange Mounting
Style HB
(NFPA Style MF6)

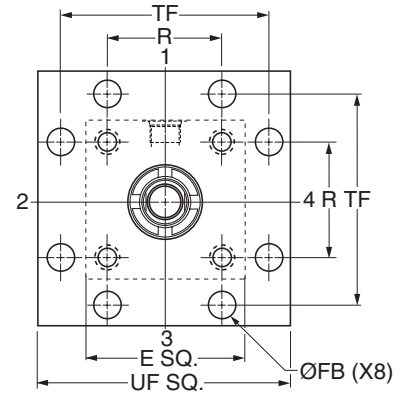
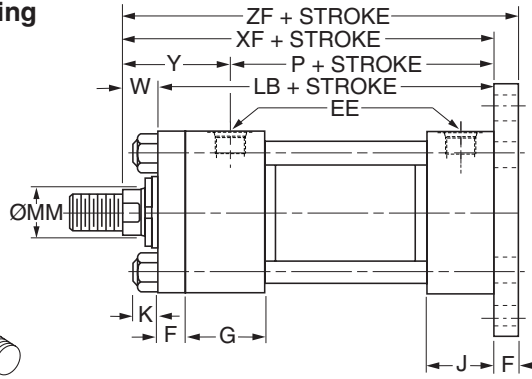
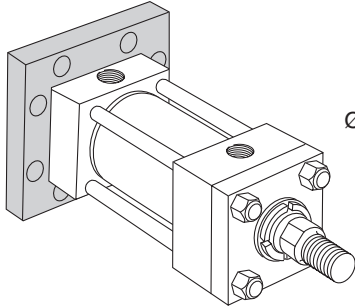

Table 1 – Dimensional and Mounting Data

Bore Ø	E	EE		F	FB Ø	G	J	K	R	TF	UF	Add Stroke	
		NPTF ¹	SAE ²									LB	P
1.50	2.50	1/2	10	0.38	0.44	1.75	1.50	0.38	1.63	3.44	4.25	5.00	2.88
2.00	3.00	1/2	10	0.63	0.56	1.75	1.50	0.44	2.05	4.13	5.13	5.25	2.88
2.50	3.50	1/2	10	0.63	0.56	1.75	1.50	0.44	2.55	4.63	5.63	5.38	3.00
3.25	4.50	3/4	12	0.75	0.69	2.00	1.75	0.56	3.25	5.88	7.13	6.25	3.50
4.00	5.00	3/4	12	0.88	0.69	2.00	1.75	0.56	3.82	6.38	7.63	6.63	3.75
5.00	6.50	3/4	12	0.88	0.94	2.00	1.75	0.81	4.95	8.19	9.75	7.13	4.25
6.00	7.50	1	16	1.00	1.06	2.25	2.25	0.88	5.73	9.44	11.25	8.38	4.88

¹NPTF ports are available at no extra charge.

²SAE straight thread ports are standard and are indicated by port number.

Table 2 – Dimensional and Mounting Data

Bore Ø	Rod No.	MM Rod Ø	W	Y	Add Stroke	
					XF	ZF
1.50	1 (std.)	0.625	0.63	2.00	5.63	6.00
	2	1.000	1.00	2.38	6.00	6.38
2.00	1 (std.)	1.000	0.75	2.38	6.00	6.63
	2	1.375	1.00	2.63	6.25	6.88
2.50	1 (std.)	1.000	0.75	2.38	6.13	6.75
	2	1.750	1.25	2.88	6.63	7.25
	3	1.375	1.00	2.63	6.38	7.00
3.25	1 (std.)	1.375	0.88	2.75	7.13	7.88
	2	2.000	1.25	3.13	7.50	8.25
	3	1.750	1.13	3.00	7.38	8.13
4.00	1 (std.)	1.750	1.00	3.00	7.63	8.50
	2	2.500	1.38	3.38	8.00	8.88
	3	2.000	1.13	3.13	7.75	8.63
5.00	1 (std.)	2.000	1.13	3.13	8.25	9.13
	2	3.500	1.38	3.38	8.50	9.38
	3	2.500	1.38	3.38	8.50	9.38
	4	3.000	1.38	3.38	8.50	9.38
6.00	1 (std.)	2.500	1.25	3.50	9.63	10.63
	2	4.000	1.25	3.50	9.63	10.63
	3	3.000	1.25	3.50	9.63	10.63
	4	3.500	1.25	3.50	9.63	10.63



Mounting Information – 1.50" to 6.00" Bore Series 2H

Cap Rectangular Flange Mounting
 Style HH
 (NFPA Style ME6)

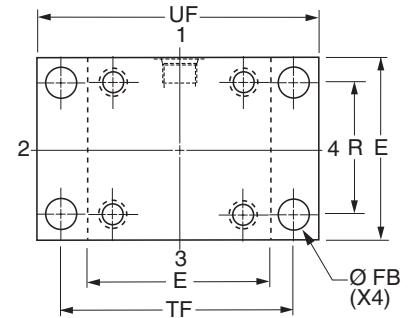
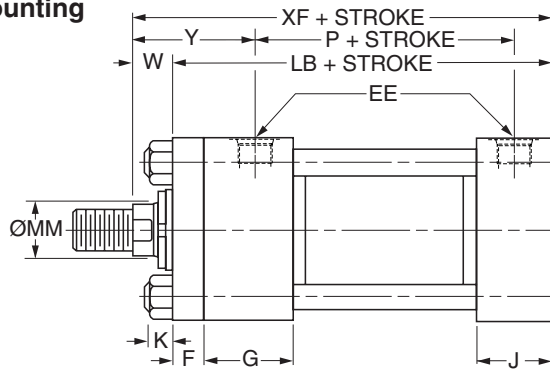
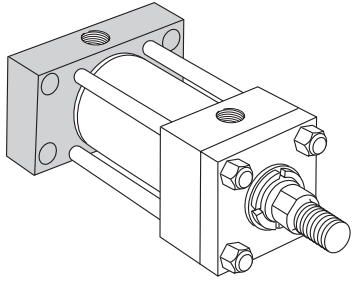

Table 1 – Dimensional and Mounting Data

Bore Ø	E	EE		F	FB Ø	G	J	K	R	TF	UF	Add Stroke	
		NPTF ¹	SAE ²									LB	P
1.50	2.50	1/2	10	0.38	0.44	1.75	1.50	0.38	1.63	3.44	4.25	5.00	2.88
2.00	3.00	1/2	10	0.63	0.56	1.75	1.50	0.44	2.05	4.13	5.13	5.25	2.88
2.50	3.50	1/2	10	0.63	0.56	1.75	1.50	0.44	2.55	4.63	5.63	5.38	3.00
3.25	4.50	3/4	12	0.75	0.69	2.00	1.75	0.56	3.25	5.88	7.13	6.25	3.50
4.00	5.00	3/4	12	0.88	0.69	2.00	1.75	0.56	3.82	6.38	7.63	6.63	3.75
5.00	6.50	3/4	12	0.88	0.94	2.00	1.75	0.81	4.95	8.19	9.75	7.13	4.25
6.00	7.50	1	16	1.00	1.06	2.25	2.25	0.88	5.73	9.44	11.25	8.38	4.88

¹NPTF ports are available at no extra charge.

²SAE straight thread ports are standard and are indicated by port number.

Table 2 – Dimensional and Mounting Data

Bore Ø	Rod No.	MM Rod Ø	W	Y	Add Stroke
					XF
1.50	1 (std.)	0.625	0.63	2.00	5.63
	2	1.000	1.00	2.38	6.00
2.00	1 (std.)	1.000	0.75	2.38	6.00
	2	1.375	1.00	2.63	6.25
2.50	1 (std.)	1.000	0.75	2.38	6.13
	2	1.750	1.25	2.88	6.63
	3	1.375	1.00	2.63	6.38
3.25	1 (std.)	1.375	0.88	2.75	7.13
	2	2.000	1.25	3.13	7.50
	3	1.750	1.13	3.00	7.38
4.00	1 (std.)	1.750	1.00	3.00	7.63
	2	2.500	1.38	3.38	8.00
	3	2.000	1.13	3.13	7.75
5.00	1 (std.)	2.000	1.13	3.13	8.25
	2	3.500	1.38	3.38	8.50
	3	2.500	1.38	3.38	8.50
	4	3.000	1.38	3.38	8.50
6.00	1 (std.)	2.500	1.25	3.50	9.63
	2	4.000	1.25	3.50	9.63
	3	3.000	1.25	3.50	9.63
	4	3.500	1.25	3.50	9.63

Mounting Information – 1.50" to 6.00" Bore Series 2H

**Side Lug Mounting
Style C
(NFPA Style MS2)**

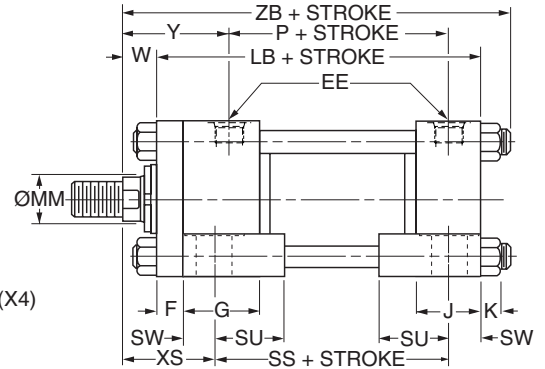
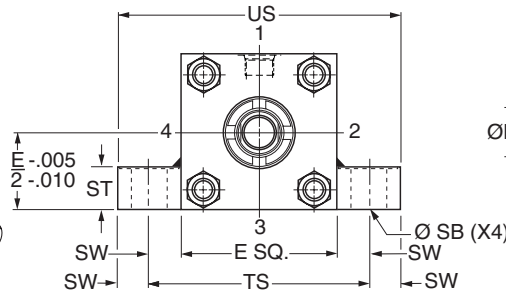
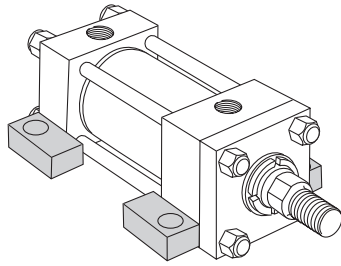

Table 1 – Dimensional and Mounting Data

Bore Ø	E	EE		F	G	J	K	SB ³ Ø	ST	SU	SW	TS	US	Add Stroke		
		NPTF ¹	SAE ²											LB	P	SS
1.50	2.50	1/2	10	0.38	1.75	1.50	0.38	0.44	0.50	0.94	0.38	3.25	4.00	5.00	2.88	3.88
2.00	3.00	1/2	10	0.63	1.75	1.50	0.44	0.56	0.75	1.25	0.50	4.00	5.00	5.25	2.88	3.63
2.50	3.50	1/2	10	0.63	1.75	1.50	0.44	0.81	1.00	1.56	0.69	4.88	6.25	5.38	3.00	3.38
3.25	4.50	3/4	12	0.75	2.00	1.75	0.56	0.81	1.00	1.56	0.69	5.88	7.25	6.25	3.50	4.13
4.00	5.00	3/4	12	0.88	2.00	1.75	0.56	1.06	1.25	2.00	0.88	6.75	8.50	6.63	3.75	4.00
5.00	6.50	3/4	12	0.88	2.00	1.75	0.81	1.06	1.25	2.00	0.88	8.25	10.00	7.13	4.25	4.50
6.00	7.50	1	16	1.00	2.25	2.25	0.88	1.31	1.50	2.50	1.13	9.75	12.00	8.38	4.88	5.13

¹NPTF ports are available at no extra charge.

²SAE straight thread ports are standard and are indicated by port number.

³Upper surface spot faced for socket head screws.

Table 2 – Dimensional and Mounting Data

Bore Ø	Rod No.	MM Rod Ø	W	XS	Y	Add Stroke
						ZB Max.
1.50	1 (std.)	0.625	0.63	1.38	2.00	6.25
	2	1.000	1.00	1.75	2.38	6.63
2.00	1 (std.)	1.000	0.75	1.88	2.38	6.69
	2	1.375	1.00	2.13	2.63	6.94
2.50	1 (std.)	1.000	0.75	2.06	2.38	6.81
	2	1.750	1.25	2.56	2.88	7.31
	3	1.375	1.00	2.31	2.63	7.06
3.25	1 (std.)	1.375	0.88	2.31	2.75	7.94
	2	2.000	1.25	2.69	3.13	8.31
	3	1.750	1.13	2.56	3.00	8.19
4.00	1 (std.)	1.750	1.00	2.75	3.00	8.50
	2	2.500	1.38	3.13	3.38	8.88
	3	2.000	1.13	2.88	3.13	8.63
5.00	1 (std.)	2.000	1.13	2.88	3.13	9.38
	2	3.500	1.38	3.13	3.38	9.63
	3	2.500	1.38	3.13	3.38	9.63
	4	3.000	1.38	3.13	3.38	9.63
6.00	1 (std.)	2.500	1.25	3.38	3.50	10.81
	2	4.000	1.25	3.38	3.50	10.81
	3	3.000	1.25	3.38	3.50	10.81
	4	3.500	1.25	3.38	3.50	10.81



Mounting Information – 1.50" to 6.00" Bore Series 2H

**Side Tapped Mounting
Style F
(NFPA Style MS4)**

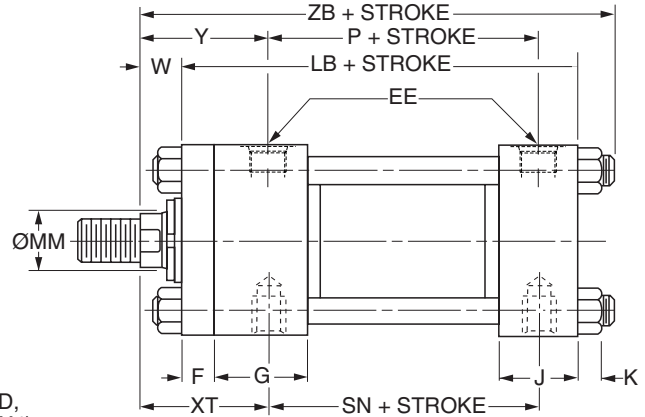
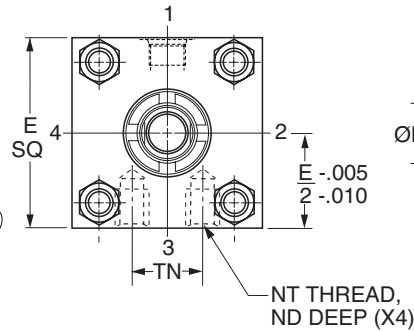
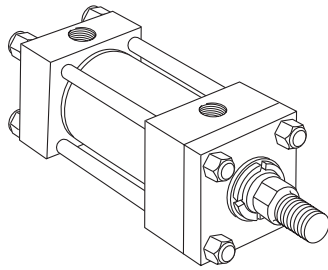

Table 1 – Dimensional and Mounting Data

Bore Ø	E	EE		F	G	J	K	ND	NT	TN	Add Stroke		
		NPTF ¹	SAE ²								LB	P	SN
1.50	2.50	1/2	10	0.38	1.75	1.50	0.38	0.38	3/8-16	0.75	5.00	2.88	2.88
2.00	3.00	1/2	10	0.63	1.75	1.50	0.44	0.44	1/2-13	0.94	5.25	2.88	2.88
2.50	3.50	1/2	10	0.63	1.75	1.50	0.44	0.50	5/8-11	1.31	5.38	3.00	3.00
3.25	4.50	3/4	12	0.75	2.00	1.75	0.56	0.69	3/4-10	1.50	6.25	3.50	3.50
4.00	5.00	3/4	12	0.88	2.00	1.75	0.56	0.69	1-8	2.06	6.63	3.75	3.75
5.00	6.50	3/4	12	0.88	2.00	1.75	0.81	1.00	1-8	2.94	7.13	4.25	4.25
6.00	7.50	1	16	1.00	2.25	2.25	0.88	1.25	1 1/4 -7	3.31	8.38	4.88	5.13

¹NPTF ports are available at no extra charge.

²SAE straight thread ports are standard and are indicated by port number.

Table 2 – Dimensional and Mounting Data

Bore Ø	Rod No.	MM Rod Ø	W	XT	Y	Add Stroke
						ZB Max.
1.50	1 (std.)	0.625	0.63	2.00	2.00	6.25
	2	1.000	1.00	2.38	2.38	6.63
2.00	1 (std.)	1.000	0.75	2.38	2.38	6.69
	2	1.375	1.00	2.63	2.63	6.94
2.50	1 (std.)	1.000	0.75	2.38	2.38	6.81
	2	1.750	1.25	2.88	2.88	7.31
	3	1.375	1.00	2.63	2.63	7.06
3.25	1 (std.)	1.375	0.88	2.75	2.75	7.94
	2	2.000	1.25	3.13	3.13	8.31
	3	1.750	1.13	3.00	3.00	8.19
4.00	1 (std.)	1.750	1.00	3.00	3.00	8.50
	2	2.500	1.38	3.38	3.38	8.88
	3	2.000	1.13	3.13	3.13	8.63
5.00	1 (std.)	2.000	1.13	3.13	3.13	9.38
	2	3.500	1.38	3.38	3.38	9.63
	3	2.500	1.38	3.38	3.38	9.63
	4	3.000	1.38	3.38	3.38	9.63
6.00	1 (std.)	2.500	1.25	3.50	3.50	10.81
	2	4.000	1.25	3.50	3.50	10.81
	3	3.000	1.25	3.50	3.50	10.81
	4	3.500	1.25	3.50	3.50	10.81

Mounting Information – 1.50" to 6.00" Bore Series 2H

Cap Fixed Clevis Mounting
Style BB
(NFPA Style MP1)

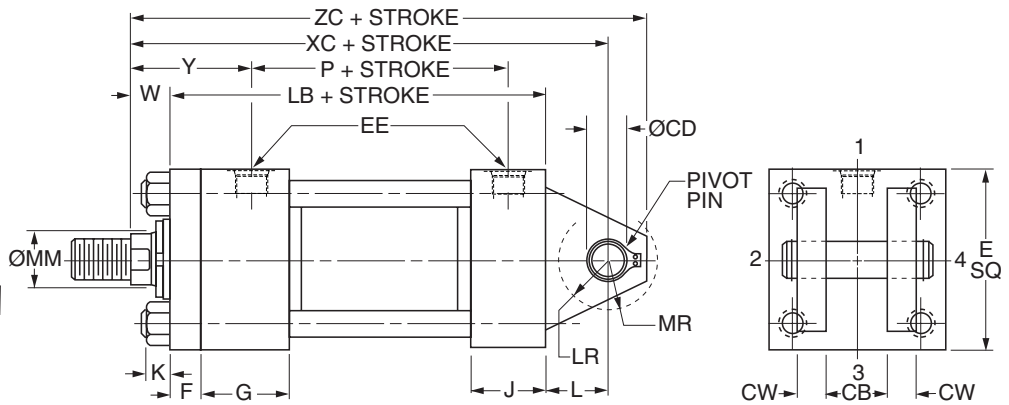
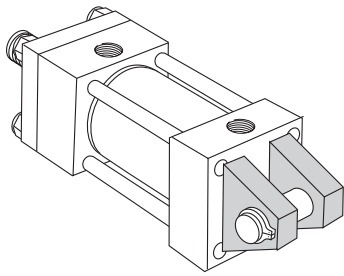

Table 1 – Dimensional and Mounting Data

Bore Ø	E	EE		CB	CD ³ Ø + .000 - .002	CW	F	G	J	K	L	LR	MR	Add Stroke	
		NPTF ¹	SAE ²											LB	P
1.50	2.50	1/2	10	0.75	.501	0.50	0.38	1.75	1.50	0.38	0.75	0.56	0.63	5.00	2.88
2.00	3.00	1/2	10	1.25	.751	0.63	0.63	1.75	1.50	0.44	1.25	1.00	0.94	5.25	2.88
2.50	3.50	1/2	10	1.25	.751	0.63	0.63	1.75	1.50	0.44	1.25	0.94	0.94	5.38	3.00
3.25	4.50	3/4	12	1.50	1.001	0.75	0.75	2.00	1.75	0.56	1.50	1.25	1.19	6.25	3.50
4.00	5.00	3/4	12	2.00	1.376	1.00	0.88	2.00	1.75	0.56	2.13	1.75	1.63	6.63	3.75
5.00	6.50	3/4	12	2.50	1.751	1.25	0.88	2.00	1.75	0.81	2.25	2.06	2.13	7.13	4.25
6.00	7.50	1	16	2.50	2.001	1.25	1.00	2.25	2.25	0.88	2.50	2.31	2.38	8.38	4.88

¹NPTF ports are available at no extra charge.

²SAE straight thread ports are standard and are indicated by port number.

³Diameter CD is Pin Diameter.

Table 2 – Dimensional and Mounting Data

Bore Ø	Rod No.	MM Rod Ø	W	Y	Add Stroke	
					XC	ZC
1.50	1 (std.)	0.625	0.63	2.00	6.38	6.88
	2	1.000	1.00	2.38	6.75	7.25
2.00	1 (std.)	1.000	0.75	2.38	7.25	8.00
	2	1.375	1.00	2.63	7.50	8.25
2.50	1 (std.)	1.000	0.75	2.38	7.38	8.13
	2	1.750	1.25	2.88	7.88	8.63
	3	1.375	1.00	2.63	7.63	8.38
3.25	1 (std.)	1.375	0.88	2.75	8.63	9.63
	2	2.000	1.25	3.13	9.00	10.00
	3	1.750	1.13	3.00	8.88	9.88
4.00	1 (std.)	1.750	1.00	3.00	9.75	11.13
	2	2.500	1.38	3.38	10.13	11.50
	3	2.000	1.13	3.13	9.88	11.25
5.00	1 (std.)	2.000	1.13	3.13	10.50	12.25
	2	3.500	1.38	3.38	10.75	12.50
	3	2.500	1.38	3.38	10.75	12.50
	4	3.000	1.38	3.38	10.75	12.50
6.00	1 (std.)	2.500	1.25	3.50	12.13	14.13
	2	4.000	1.25	3.50	12.13	14.13
	3	3.000	1.25	3.50	12.13	14.13
	4	3.500	1.25	3.50	12.13	14.13



Mounting Information – 1.50" to 6.00" Bore Series 2H

**Head Trunnion Mounting
Style D
(NFPA Style MT1)**

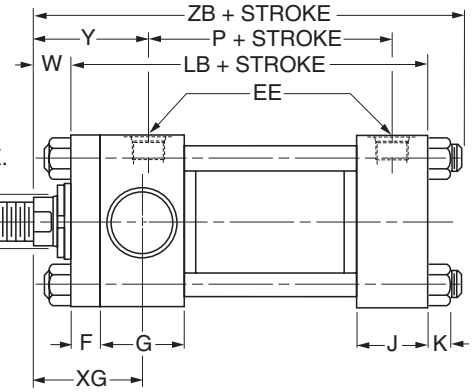
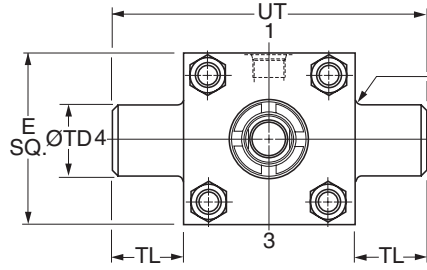
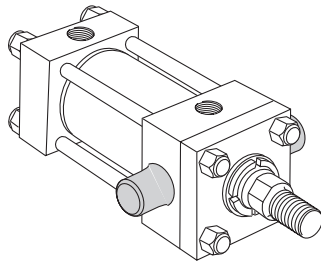

Table 1 – Dimensional and Mounting Data

Bore Ø	E	EE		F	G	J	K	TD Ø +0.000 -0.001	TL	UT	Add Stroke	
		NPTF ¹	SAE ²								LB	P
1.50	2.50	1/2	10	0.38	1.75	1.50	0.38	1.000	1.00	4.50	5.00	2.88
2.00	3.00	1/2	10	0.63	1.75	1.50	0.44	1.375	1.38	5.75	5.25	2.88
2.50	3.50	1/2	10	0.63	1.75	1.50	0.44	1.375	1.38	6.25	5.38	3.00
3.25	4.50	3/4	12	0.75	2.00	1.75	0.56	1.750	1.75	8.00	6.25	3.50
4.00	5.00	3/4	12	0.88	2.00	1.75	0.56	1.750	1.75	8.50	6.63	3.75
5.00	6.50	3/4	12	0.88	2.00	1.75	0.81	1.750	1.75	10.00	7.13	4.25
6.00	7.50	1	16	1.00	2.25	2.25	0.88	2.000	2.00	11.50	8.38	4.88

¹NPTF ports are available at no extra charge.

²SAE straight thread ports are standard and are indicated by port number.

Table 2 – Dimensional and Mounting Data

Bore Ø	Rod No.	MM Rod Ø	W	XG	Y	Add Stroke
						ZB Max.
1.50	1 (std.)	0.625	0.63	1.88	2.00	6.25
	2	1.000	1.00	2.25	2.38	6.63
2.00	1 (std.)	1.000	0.75	2.25	2.38	6.69
	2	1.375	1.00	2.50	2.63	6.94
2.50	1 (std.)	1.000	0.75	2.25	2.38	6.81
	2	1.750	1.25	2.75	2.88	7.31
	3	1.375	1.00	2.50	2.63	7.06
3.25	1 (std.)	1.375	0.88	2.63	2.75	7.94
	2	2.000	1.25	3.00	3.13	8.31
	3	1.750	1.13	2.88	3.00	8.19
4.00	1 (std.)	1.750	1.00	2.88	3.00	8.50
	2	2.500	1.38	3.25	3.38	8.88
	3	2.000	1.13	3.00	3.13	8.63
5.00	1 (std.)	2.000	1.13	3.00	3.13	9.38
	2	3.500	1.38	3.25	3.38	9.63
	3	2.500	1.38	3.25	3.38	9.63
	4	3.000	1.38	3.25	3.38	9.63
6.00	1 (std.)	2.500	1.25	3.38	3.50	10.81
	2	4.000	1.25	3.38	3.50	10.81
	3	3.000	1.25	3.38	3.50	10.81
	4	3.500	1.25	3.38	3.50	10.81

Mounting Information – 1.50" to 6.00" Bore Series 2H

Cap Trunnion Mounting
Style DB
(NFPA Style MT2)

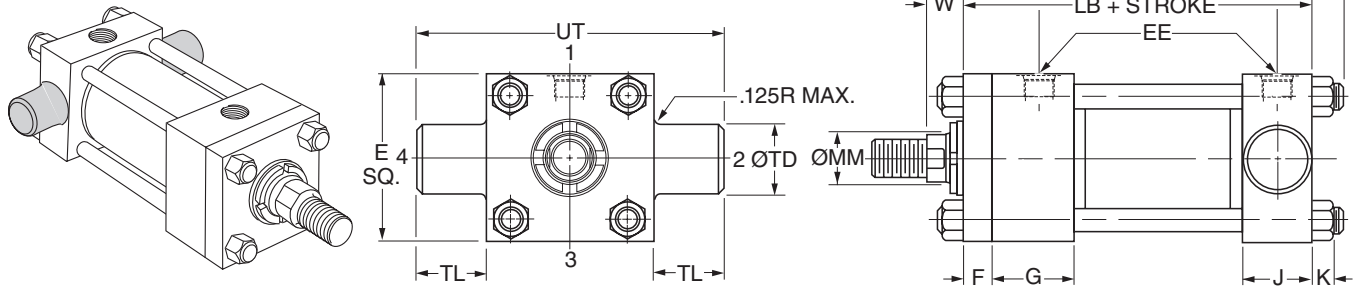

Table 1 – Dimensional and Mounting Data

Bore Ø	E	EE		F	G	J	K	TD Ø +0.000 -0.001	TL	UT	Add Stroke	
		NPTF ¹	SAE ²								LB	P
1.50	2.50	1/2	10	0.38	1.75	1.50	0.38	1.000	1.00	4.50	5.00	2.88
2.00	3.00	1/2	10	0.63	1.75	1.50	0.44	1.375	1.38	5.75	5.25	2.88
2.50	3.50	1/2	10	0.63	1.75	1.50	0.44	1.375	1.38	6.25	5.38	3.00
3.25	4.50	3/4	12	0.75	2.00	1.75	0.56	1.750	1.75	8.00	6.25	3.50
4.00	5.00	3/4	12	0.88	2.00	1.75	0.56	1.750	1.75	8.50	6.63	3.75
5.00	6.50	3/4	12	0.88	2.00	1.75	0.81	1.750	1.75	10.00	7.13	4.25
6.00	7.50	1	16	1.00	2.25	2.25	0.88	2.000	2.00	11.50	8.38	4.88

¹NPTF ports are available at no extra charge.

²SAE straight thread ports are standard and are indicated by port number.

Table 2 – Dimensional and Mounting Data

Bore Ø	Rod No.	MM Rod Ø	W	Y	Add Stroke	
					XJ	ZB Max.
1.50	1 (std.)	0.625	0.63	2.00	4.88	6.25
	2	1.000	1.00	2.38	5.25	6.63
2.00	1 (std.)	1.000	0.75	2.38	5.25	6.69
	2	1.375	1.00	2.63	5.50	6.94
2.50	1 (std.)	1.000	0.75	2.38	5.38	6.81
	2	1.750	1.25	2.88	5.88	7.31
	3	1.375	1.00	2.63	5.63	7.06
3.25	1 (std.)	1.375	0.88	2.75	6.25	7.94
	2	2.000	1.25	3.13	6.63	8.31
	3	1.750	1.13	3.00	6.50	8.19
4.00	1 (std.)	1.750	1.00	3.00	6.75	8.50
	2	2.500	1.38	3.38	7.13	8.88
	3	2.000	1.13	3.13	6.88	8.63
5.00	1 (std.)	2.000	1.13	3.13	7.38	9.38
	2	3.500	1.38	3.38	7.63	9.63
	3	2.500	1.38	3.38	7.63	9.63
	4	3.000	1.38	3.38	7.63	9.63
6.00	1 (std.)	2.500	1.25	3.50	8.38	10.81
	2	4.000	1.25	3.50	8.38	10.81
	3	3.000	1.25	3.50	8.38	10.81
	4	3.500	1.25	3.50	8.38	10.81



Mounting Information – 1.50" to 6.00" Bore Series 2H

Intermediate Fixed Trunnion Mounting
Style DD
 (NFPA Style MT4)

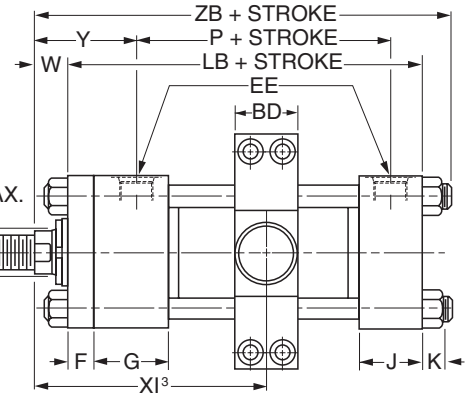
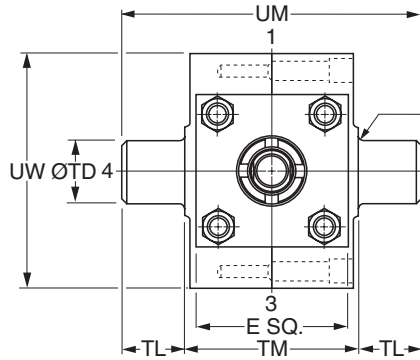
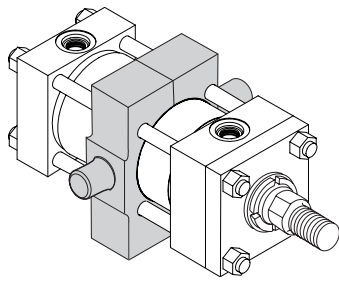

Table 1 – Dimensional and Mounting Data

Bore Ø	BD	E	EE		F	G	J	K	TD Ø +0.000 -0.001	TL	TM	UM	UT	UW	Add Stroke	
			NPTF ¹	SAE ²											LB	P
1.50	1.25	2.50	1/2	10	0.38	1.75	1.50	0.38	1.000	1.00	3.00	5.00	4.50	3.38	5.00	2.88
2.00	1.50	3.00	1/2	10	0.63	1.75	1.50	0.44	1.375	1.38	3.50	6.25	5.75	4.13	5.25	2.88
2.50	1.50	3.50	1/2	10	0.63	1.75	1.50	0.44	1.375	1.38	4.00	6.75	6.25	4.63	5.38	3.00
3.25	2.00	4.50	3/4	12	0.75	2.00	1.75	0.56	1.750	1.75	5.00	8.50	8.00	5.81	6.25	3.50
4.00	2.00	5.00	3/4	12	0.88	2.00	1.75	0.56	1.750	1.75	5.50	9.00	8.50	6.38	6.63	3.75
5.00	2.00	6.50	3/4	12	0.88	2.00	1.75	0.81	1.750	1.75	7.00	10.50	10.00	7.75	7.13	4.25
6.00	3.00	7.50	1	16	1.00	2.25	2.25	0.88	2.000	2.00	8.50	12.50	11.50	10.38	8.38	4.88

¹NPTF ports are available at no extra charge.

²SAE straight thread ports are standard and are indicated by port number.

Table 2 – Dimensional and Mounting Data

Bore Ø	Rod No.	MM Rod Ø	W	Y	Min. XI ³	Min. Stroke	Add Stroke
							ZB Max
1.50	1 (std.)	0.625	0.63	2.00	3.44	0	6.25
	2	1.000	1.00	2.38	3.81	0	6.63
2.00	1 (std.)	1.000	0.75	2.38	3.94	0.25	6.69
	2	1.375	1.00	2.63	4.19	0.25	6.94
2.50	1 (std.)	1.000	0.75	2.38	3.94	0.13	6.81
	2	1.750	1.25	2.88	4.44	0.13	7.31
	3	1.375	1.00	2.63	4.19	0.13	7.06
3.25	1 (std.)	1.375	0.88	2.75	4.69	0.38	7.94
	2	2.000	1.25	3.13	5.06	0.38	8.31
	3	1.750	1.13	3.00	4.94	0.38	8.19
4.00	1 (std.)	1.750	1.00	3.00	4.94	0.13	8.50
	2	2.500	1.38	3.38	5.31	0.13	8.88
	3	2.000	1.13	3.13	5.06	0.13	8.63
5.00	1 (std.)	2.000	1.13	3.13	5.06	0	9.38
	2	3.500	1.38	3.38	5.31	0	9.63
	3	2.500	1.38	3.38	5.31	0	9.63
	4	3.000	1.38	3.38	5.31	0	9.63
6.00	1 (std.)	2.500	1.25	3.50	6.06	0.25	10.81
	2	4.000	1.25	3.50	6.06	0.25	10.81
	3	3.000	1.25	3.50	6.06	0.25	10.81
	4	3.500	1.25	3.50	6.06	0.25	10.81

³Dimension XI to be specified by customer.

Mounting Information – 1.50" to 6.00" Bore Series 2H

Heavy Duty Intermediate Fixed Trunnion Mounting

Style DE
(NFPA Style MT4)

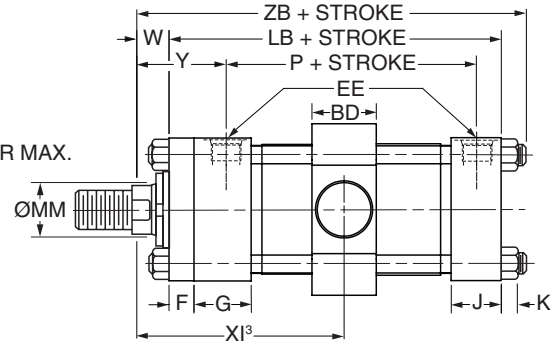
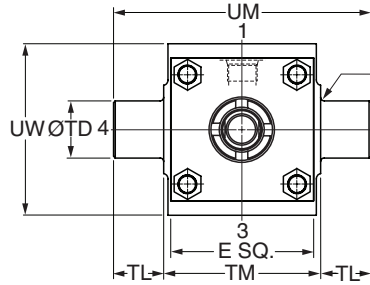
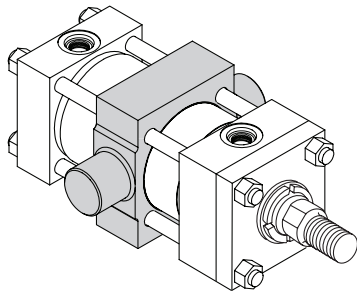

Table 1 – Dimensional and Mounting Data

Bore Ø	BD	E	EE		F	G	J	K	TD Ø +0.000 -0.001	TL	TM	UM	UW	Add Stroke		Style DE Minimum Stroke
			NPTF ¹	SAE ²										LB	P	
4.00	2.25	5.00	3/4	12	0.88	2.00	1.75	0.56	2.000	1.75	5.50	9.00	6.00	6.63	3.75	0.13
5.00	2.75	6.50	3/4	12	0.88	2.00	1.75	0.81	2.500	1.75	7.00	10.50	7.50	7.13	4.25	0.00
6.00	3.25	7.50	1	16	1.00	2.25	2.25	0.88	3.000	2.00	8.50	12.50	9.50	8.38	4.88	0.25

¹NPTF ports are available at no extra charge.

²SAE straight thread ports are standard and are indicated by port number.

Table 2 – Dimensional and Mounting Data

Bore Ø	Rod No.	MM Rod Ø	Min. XI ³	W	Y	Add Stroke
						ZB Max.
4.00	1 (std.)	1.750	4.94	1.00	3.00	8.50
	2	2.500	5.31	1.38	3.38	8.88
	3	2.000	5.06	1.13	3.13	8.63
5.00	1 (std.)	2.000	5.06	1.13	3.13	9.38
	2	3.500	5.31	1.38	3.38	9.63
	3	2.500	5.31	1.38	3.38	9.63
	4	3.000	5.31	1.38	3.38	9.63
6.00	1 (std.)	2.500	6.06	1.25	3.50	10.81
	2	4.000	6.06	1.25	3.50	10.81
	3	3.000	6.06	1.25	3.50	10.81
	4	3.500	6.06	1.25	3.50	10.81

³Dimension XI to be specified by customer.



Mounting Information – 1.50" to 6.00" Bore Series 2H

Spherical Bearing Mounting
Style SB

Bore Ø	Maximum Operating psi ¹
1.50	1500
2.00	2200
2.50	1450
3.25	1500
4.00	1850
5.00	2000
6.00	1800

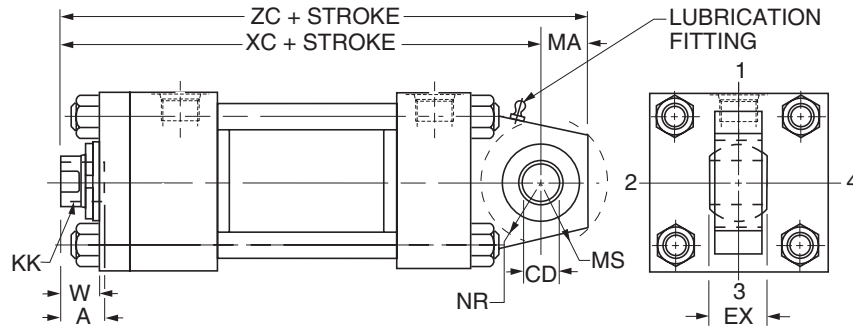

Table 1 — Dimensional and Mounting Data

Bore Ø	Rod No.	MM Rod Ø	Thread		A	CD ² Ø	EX	MA	MS	NR	W	Add Stroke		
			Style 9 KK ³	Style 7 KK ³								XC	ZC	
1.50	1 (Std.)	0.625	7/16-20	—	0.75	-.0005	0.44	0.75	0.94	0.63	0.63	6.38	7.13	
	2	1.000	—	7/16-20	0.75	.5000						6.75	7.50	
2.00	1 (Std.)	1.000	3/4-16	—	1.13	-.0005	0.66	1.00	1.38	1.00	0.75	7.25	8.25	
	2	1.375	—	3/4-16	1.13	.7500						7.50	8.50	
2.50	1 (Std.)	1.000	3/4-16	—	1.13	-.0005	0.66	1.00	1.38	1.00	0.75	7.38	8.38	
	2	1.750	—	3/4-16	1.13							1.25	7.88	8.88
	3	1.375	—	3/4-16	1.13							1.00	7.63	8.63
3.25	1 (Std.)	1.375	1-14	—	1.63	-.0005	0.88	1.25	1.69	1.25	0.88	8.63	9.88	
	2	2.000	—	1-14	1.63							1.25	9.00	10.25
	3	1.750	—	1-14	1.63							1.13	8.88	10.13
4.00	1 (Std.)	1.750	1 1/4-12	—	2.00	-.0005	1.19	1.88	2.44	1.63	1.00	9.75	11.63	
	2	2.500	—	1 1/4-12	2.00							1.38	10.13	12.00
	3	2.000	—	1 1/4-12	2.00							1.13	9.88	11.75
5.00	1 (Std.)	2.000	1 1/2-12	—	2.25	-.0005	1.53	2.50	2.88	2.06	1.13	10.50	13.00	
	2	3.500	—	1 1/2-12	2.25							1.38	10.75	13.25
	3	2.500	—	1 1/2-12	2.25							1.38	10.75	13.25
	4	3.000	—	1 1/2-12	2.25							1.38	10.75	13.25
6.00	1 (Std.)	2.500	1 7/8-12	—	3.00	-.0005	1.75	2.50	3.31	2.38	1.25	12.13	14.63	
	2	4.000	—	1 7/8-12	3.00							1.25	12.13	14.63
	3	3.000	—	1 7/8-12	3.00							1.25	12.13	14.63
	4	3.500	—	1 7/8-12	3.00							1.25	12.13	14.63

Note: for additional dimensions see Series 2H Style BB mount.

¹ Maximum operating pressure at 4:1 design factor is based on tensile strength of material. Pressure ratings are based on standard commercial bearing ratings.

² Dimension "CD" is hole diameter.

³ Threads listed are also for a spherical rod eye which match style 9 or style 7. The spherical rod eye pin diameter matches the cap pin and (if required) needs to be purchased separately; see 2H/3H mounting accessories for detailed information.

Table 2 – Recommended maximum swivel angle on each side of the cylinder centerline.

Bore Ø	Head End Mounted		Cap End Mounted	
	Angle a	Tan. of a	Angle a	Tan. of a
1.50	2.00°	.035	2.00°	.035
2.00	2.50°	.044	4.50°	.079
2.50	2.50°	.044	4.50°	.079
3.25	3.00°	.052	3.00°	.052
4.00	2.50°	.044	3.00°	.052
5.00	3.00°	.052	3.00°	.052
6.00	3.00°	.052	3.00°	.052

Note: Dimension X is the maximum off center mounting of the cylinder. To determine dimension X for various stroke lengths multiply the distance between pivot pin holes by tangent of angle a. For extended position use X = XL + 2X stroke.

Mounting Information

Head End Mounting

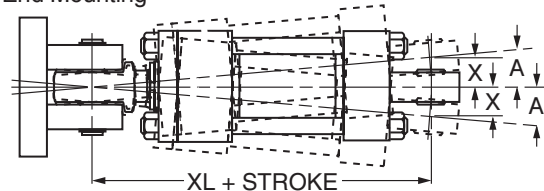

Cap End Mounting

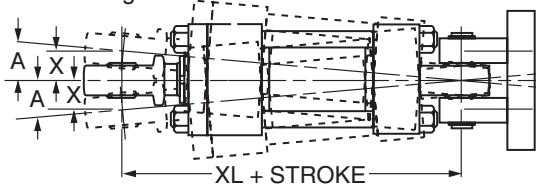

**Double Rod Cylinder
Style K**

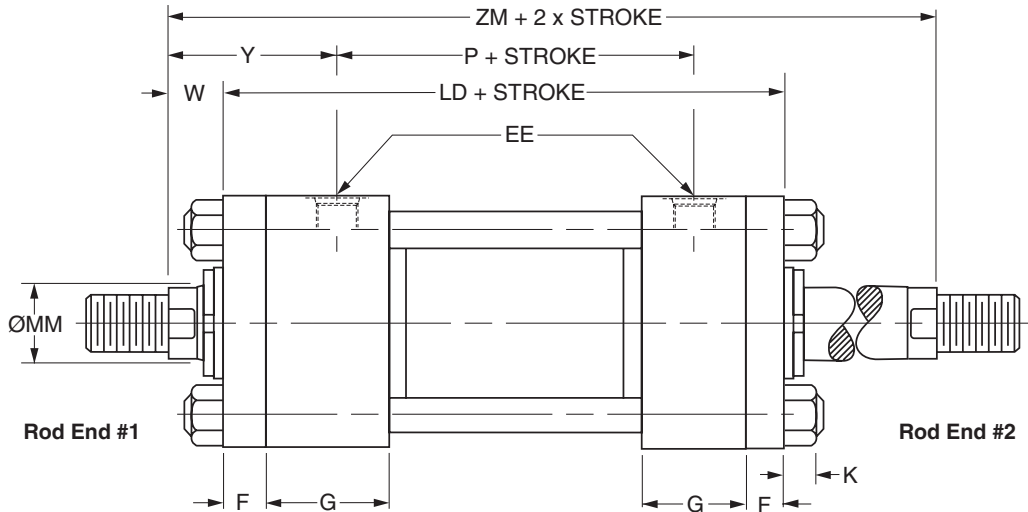

Mounting Styles for Single Rod Models	Mounting Styles for Corresponding Double Rod Models ¹	Dimensions Shown on This Page Supplement Dimensions on Pages Listed Below
		1.50" - 6.00" Bores Page No.
T	KT	12
TB	KTB	12
TD	KTD	12
J	KJ	13
JB	KJB	14
JJ	KJJ	15
C	KC	19
F	KF	20
D	KD	22
DD	KDD ²	24
DE	KDE ²	25

¹ If only one end of these Double Rod Cylinders is to be cushioned, be sure to specify clearly which end this will be.

² Specify XI dimension from rod end #1.

Bore Ø	Rod No.	MM Rod Ø	Add Stroke			Add 2X Stroke
			LD	SNK	SSK	ZM
1.50	1 (std.)	0.625	5.63	2.88	4.13	6.88
	2	1.000	5.63	2.88	4.13	7.63
2.00	1 (std.)	1.000	6.13	2.88	3.88	7.63
	2	1.375	6.13	2.88	3.88	8.13
2.50	1 (std.)	1.000	6.25	3.00	3.63	7.75
	2	1.750	6.25	3.00	3.63	8.75
	3	1.375	6.25	3.00	3.63	8.25
3.25	1 (std.)	1.375	7.25	3.50	4.38	9.00
	2	2.000	7.25	3.50	4.38	9.75
	3	1.750	7.25	3.50	4.38	9.50
4.00	1 (std.)	1.750	7.75	3.75	4.25	9.75
	2	2.500	7.75	3.75	4.25	10.50
	3	2.000	7.75	3.75	4.25	10.00
5.00	1 (std.)	2.000	8.25	4.25	4.75	10.50
	2	3.500	8.25	4.25	4.75	11.00
	3	2.500	8.25	4.25	4.75	11.00
	4	3.000	8.25	4.25	4.75	11.00
6.00	1 (std.)	2.500	9.38	4.88	5.13	11.88
	2	4.000	9.38	4.88	5.13	11.88
	3	3.000	9.38	4.88	5.13	11.88
	4	3.500	9.38	4.88	5.13	11.88
Replaces On single rod mounting styles:			LB	SN	SS	-
			All Mtg. Styles	F	C	All Mtg. Styles

**How to Use Double Rod Cylinder
Dimension Drawings**

To determine dimensions for a double rod cylinder, first refer to the desired single rod mounting style cylinder shown on preceding pages of this catalog. (See table above.) After selecting necessary dimensions from that drawing, return to this page supplement the single rod dimensions with those shown on drawing at right and dimension table below. Note that double rod cylinders have a head (Dim. G) at both ends and that dimension LD replaces LB. The double rod dimensions differ from, or are in addition to those for single

rod cylinders shown on preceding pages and provide the information needed to completely dimension a double rod cylinder.

On a double rod cylinder where the two rod ends are different, be sure to clearly state which rod end is to be assembled at which end. Port position 1 is standard. If other than standard, specify pos. 2, 3 or 4 when viewed from rod end #1 only. See port position information in Section E.

Bolt-On Gland Option Series 2HD & 3HD Heavy Duty Hydraulic Cylinders



Now Featuring Optional Bolt-On Gland

**For 1.50"-6.00" Bore Series 2H and
7.00" & 8.00" Bore Series 3H Cylinders**

- **Non-threaded gland is clamped between bolt-on circular retainer and head for simplified service**
- **Polyurethane Rod Seal with multiple sealing edges for leak proof service**
- **Long inboard rod bearing surface that is lubricated from within**

Parker Series 2HD & 3HD – your best choice in heavy duty hydraulic cylinders

Parker Series 2HD and 3HD hydraulic cylinders offer increased durability and ease of service with the addition of a bolt-on rod gland. The 2HD/3HD rod gland was designed to withstand the toughest applications while maintaining the original dimensional envelope of the

Series 2H and 3H cylinder. When requesting this option, please take note of the following page that depicts rod gland retainer dimensions unique to the rod end of the 2HD/3HD cylinder. All other dimensions will remain the same as the standard Series 2H or 3H cylinder.



Primary Seal – Polyurethane Rod Seal is a proven leak proof design – completely self-compensating and self-relieving to withstand variations and conform to mechanical deflection that may occur. Alternative seal materials are available to suit your application.

Secondary Seal – Rod Wiper – wipes clean any oil film adhering to the rod on the extend stroke and cleans the rod on the return stroke.

Rod Gland Assembly – Bronze gland is externally removable without cylinder disassembly. Long inboard bearing surface is ahead of the seals assuring lubrication by cylinder operating fluid.

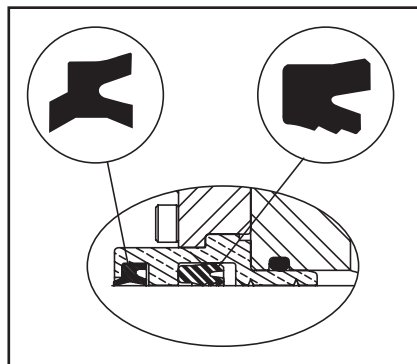
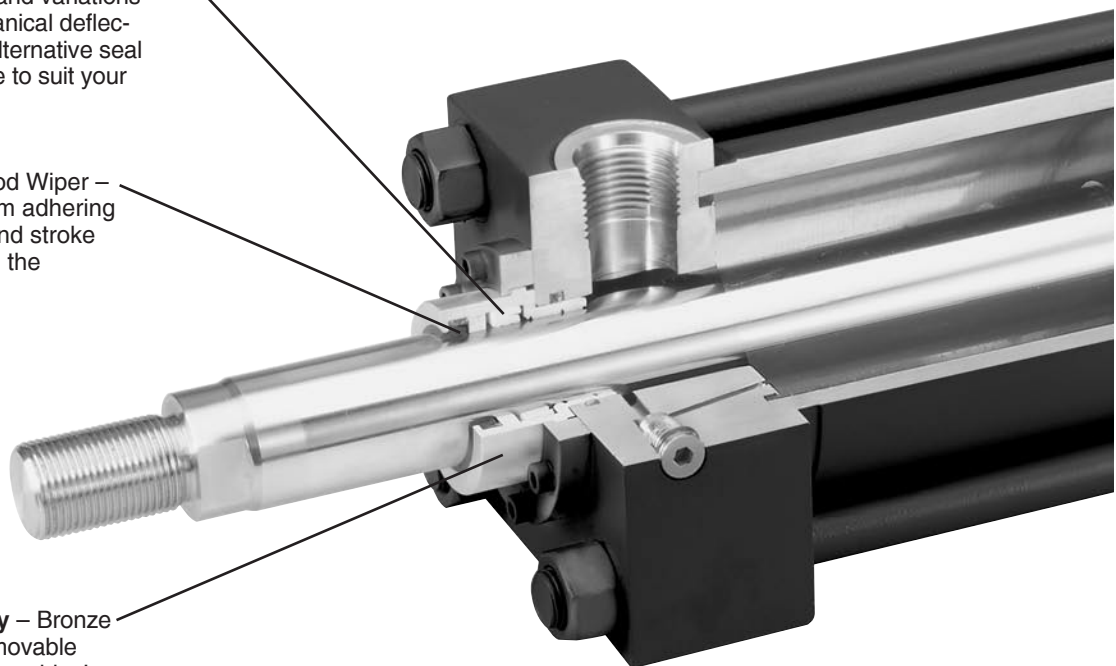

Gland Assembly

Gland Assembly is externally removable without cylinder disassembly. An O-ring is used as a seal between the gland and head. The rod seal has multiple sealing edges to produce “dry rod” performance. It is molded from a special polyurethane material that is extremely resistant to abrasion and extrusion, resulting in exceptional service life. Wiperseal cleans rod of dirt, preventing it from entering the gland and also acts as a secondary rod seal.

2HD / 3HD Rod Gland Dimensional Comparison

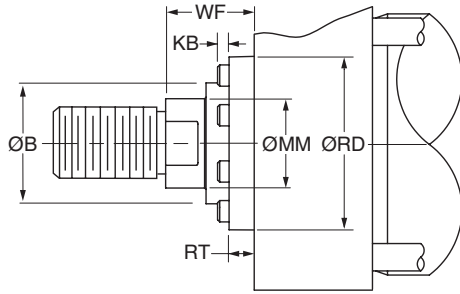

Bolt On Rod Gland (B)

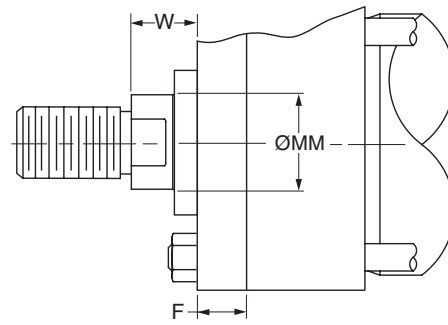

Tie Rod Retained Gland (R)

Bore Ø	Rod No.	MM Rod Ø	2HD Rod Gland Retention				Bolt On Rod Gland Dimensions							
			Mounting Style				B Ø +0.000 -0.002	RD Ø	RT	KB	VF	W	WF	F
			TC, H, HB, HH, C, F, D, DB, DD, DE, BB, SB	TB, TD	J, JB ¹	JJ								
1.50	1 (Std.)	0.625	B	R	R	B	1.124	1.94	0.38	0.19	0.25	0.63	1.00	0.38
	2	1.000	R	R	R	B	1.499	2.38	0.38	0.19	0.50	1.00	1.38	0.38
2.00	1 (Std.)	1.000	B	R	R	B	1.499	2.38	0.38	0.19	0.50	0.75	1.38	0.63
	2	1.375	R	R	R	B	1.999	2.88	0.38	0.19	0.63	1.00	1.63	0.63
2.50	1 (Std.)	1.000	B	B	B	B	1.499	2.38	0.38	0.19	0.50	0.75	1.38	0.63
	2	1.750	B	B	B	B	2.374	3.47	0.63	0.19	0.50	1.25	1.88	0.63
	3	1.375	B	B	R	B	1.999	2.88	0.38	0.19	0.63	1.00	1.63	0.63
3.25	1 (Std.)	1.375	B	B	B	B	1.999	2.88	0.38	0.19	0.63	0.88	1.63	0.75
	2	2.000	B	B	B	B	2.624	3.72	0.63	0.19	0.50	1.25	2.00	0.75
	3	1.750	B	B	B	B	2.374	3.47	0.63	0.25	0.50	1.13	1.88	0.75
4.00	1 (Std.)	1.750	B	B	B	B	2.374	3.47	0.63	0.19	0.50	1.00	1.88	0.88
	2	2.500	B	B	B	B	3.124	4.25	0.63	0.25	0.63	1.38	2.25	0.88
	3	2.000	B	B	B	B	2.624	3.72	0.63	0.25	0.50	1.13	2.00	0.88
5.00	1 (Std.)	2.000	B	B	B	B	2.624	3.72	0.63	0.25	0.50	1.13	2.00	0.88
	2	3.500	B	B	B	B	4.249	5.94	0.94	0.25	0.31	1.38	2.25	0.88
	3	2.500	B	B	B	B	3.124	4.25	0.63	-	0.63	1.38	2.25	0.88
	4	3.000	B	B	B	B	3.749	5.44	0.88	-	0.31	1.38	2.25	0.88
6.00	1 (Std.)	2.500	B	B	B	B	3.124	4.25	0.63	0.25	0.63	1.25	2.25	1.00
	2	4.000	B	B	B	B	4.749	6.31	0.94	-	0.31	1.25	2.25	1.00
	3	3.000	B	B	B	B	3.749	5.44	0.88	-	0.31	1.25	2.25	1.00
	4	3.500	B	B	B	B	4.249	5.94	0.94	-	0.31	1.25	2.25	1.00
7.00	1 (Std.)	3.000	B	B	B	B	3.749	5.44	0.88	-	0.31	-	2.25	1.00
	2	5.000	B	B	B	B	5.749	7.44	0.94	-	0.31	-	2.25	1.00
	3	3.500	B	B	B	B	4.249	5.94	0.94	-	0.31	-	2.25	1.00
	4	4.000	B	B	B	B	4.749	6.31	0.94	-	0.31	-	2.25	1.00
	5	4.500	B	B	B	B	5.249	6.94	0.94	-	0.31	-	2.25	1.00
8.00	1 (Std.)	3.500	B	B	B	B	4.249	5.94	0.94	-	0.31	-	2.25	1.00
	2	5.500	B	B	B	B	6.249	7.94	0.94	-	0.31	-	2.25	1.00
	3	4.000	B	B	B	B	4.749	6.31	0.94	-	0.31	-	2.25	1.00
	4	4.500	B	B	B	B	5.249	6.94	0.94	-	0.31	-	2.25	1.00
	5	5.000	B	B	B	B	5.749	7.44	0.94	-	0.31	-	2.25	1.00

B = Bolt-On Gland with Circular Retainer

R = Tie Rod Retained Gland

¹ 2H J & JB Mounts have reduced pressure ratings. Refer to J and JB mounts in 2H Section for de-rated operating pressure associated with the use of the 2HD gland.

High Pressure Hydraulic Cylinders

Series 3H

7.00" through 20.00"

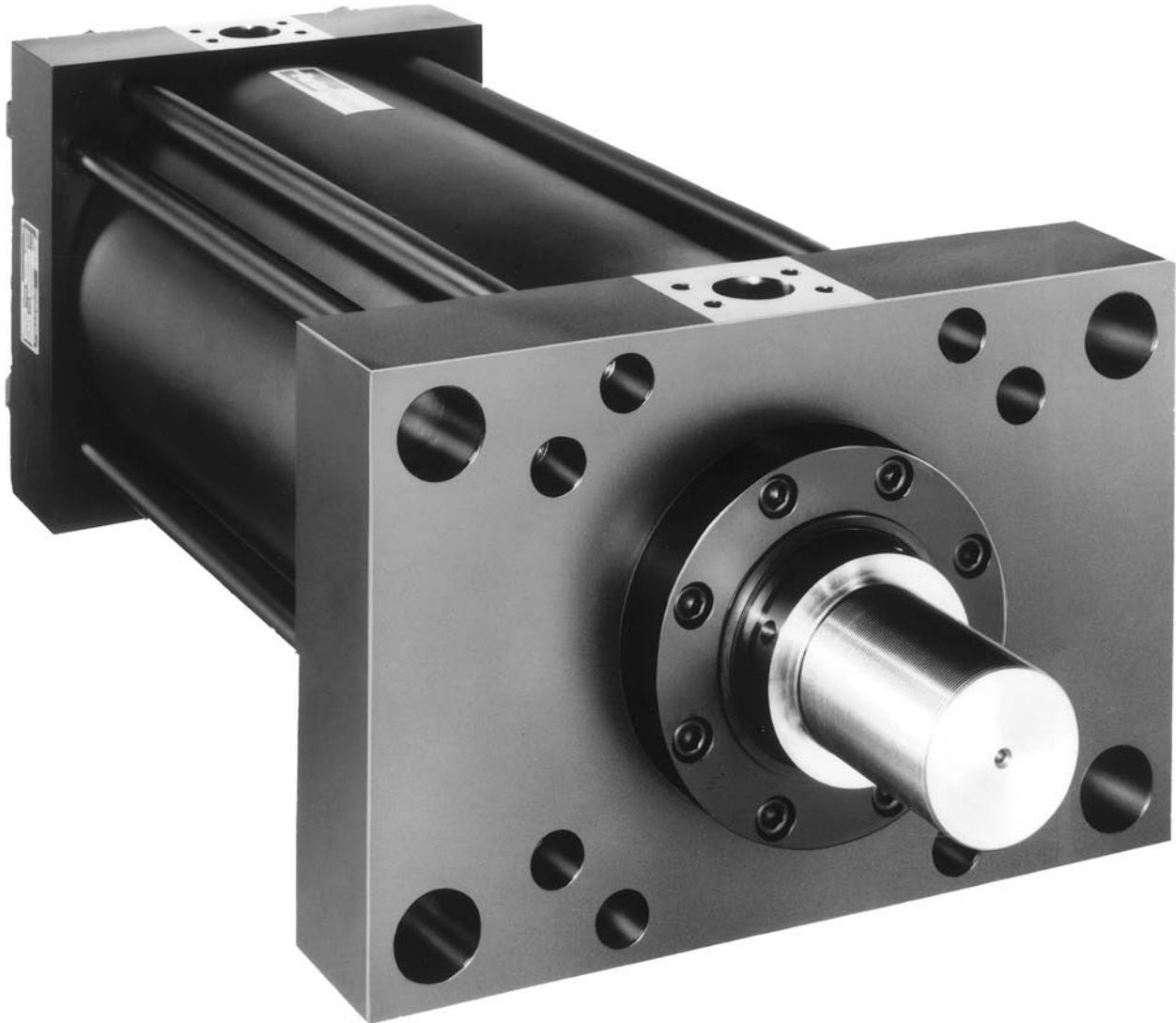

B

Heavy Duty Service – Industrial Tie-Rod Construction

- Nominal Pressure – 3000 psi
- Sixteen Standard Mounting Styles –
7.00" and 8.00" Bore
- Twelve Standard Mounting Styles –
10.00" through 20.00" Bore

The large bore, high pressure hydraulic cylinder Parker designed to meet your needs

Parker Series 3H cylinders provide unmatched reliability, performance, and innovative design features that aid in increasing productivity while reducing operating costs.

Parker's externally removable bolt-on gland assembly makes preventive and routine maintenance quick and easy! In many cases, the cylinder does not have to be removed or disassembled to facilitate service. Our innovative design provides for fast turn around, reduced downtime, and increased productivity.

In addition to our patented removable gland assembly, Series 3H cylinders also include a multitude of

innovative design features such as: anti-extrusion body end seals, floating cushions, hi load piston (standard), and various port and rod end options to meet your application requirements.

Every Series 3H cylinder is individually tested before leaving our plant to assure proper and leak free operation. All Series 3H cylinders come with an 18 month warranty standard.

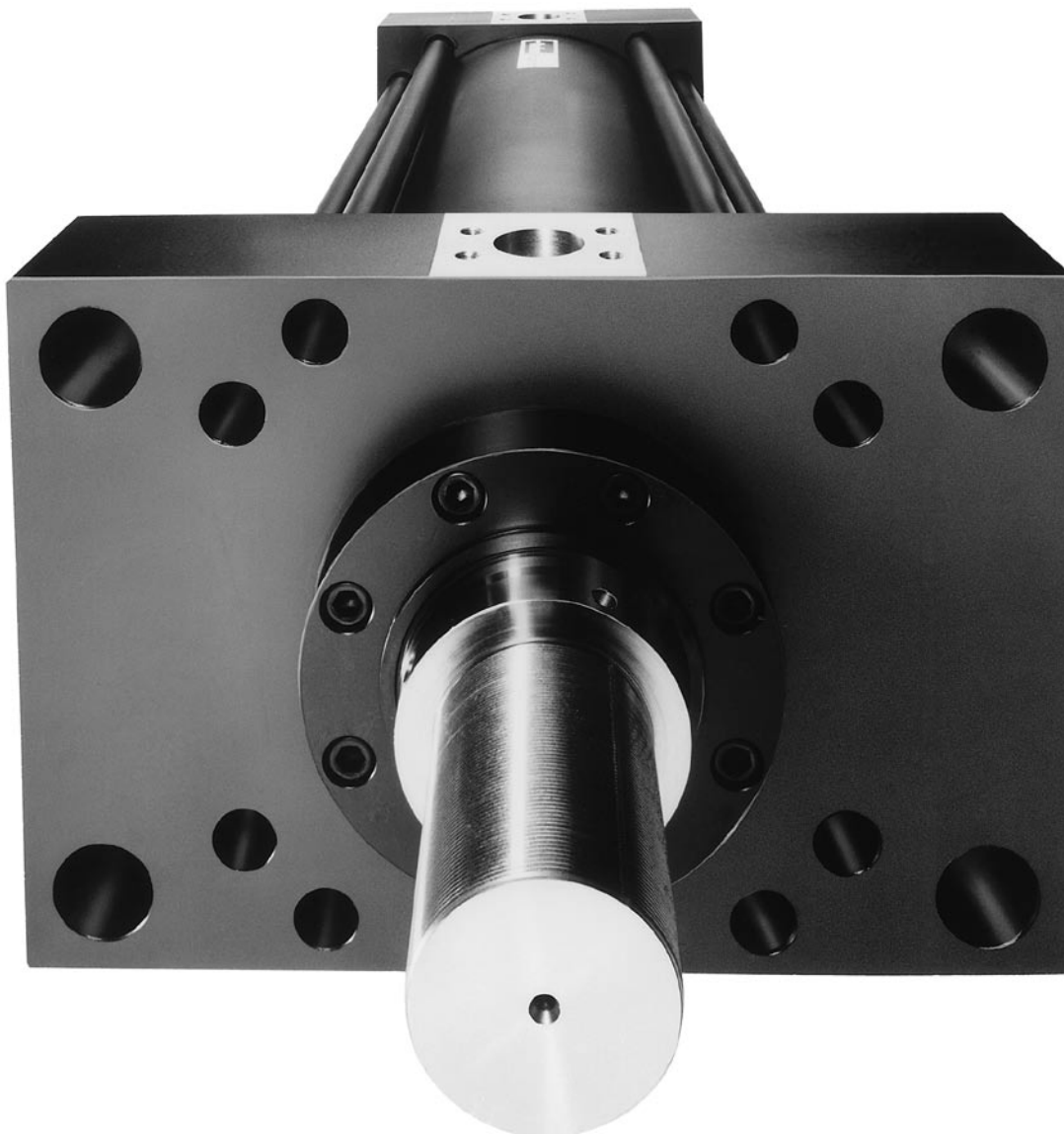

Section B

Series 3H Heavy Duty Hydraulic Cylinders

	7.00" & 8.00" Bore	10.00" through 20.00" Bore
Specifications, Mounting Styles	34	35
3H Cylinder Model Code & How to Order	36	36
Rod End Styles and Dimensions	38	39
TB, TC and TD Dimensions	40	53
J Mount Dimensions	43	—
JB Mount Dimensions	44	56
JJ Mount Dimensions	45	54, 55
C Mount Dimensions	46	59
F Mount Dimensions	46	—
HH Mount Dimensions	42	57
HB Mount Dimensions	42	58
H Mount Dimensions	41	—
BB Mount Dimensions	47	60
D Mount Dimensions	48	61
DB Mount Dimensions	49	62
DD Mount Dimensions	50	63
DE Mount Dimensions	51	—
Double Rod End Cylinders	52	64



Specifications / Mountings – 7.00" and 8.00" Series 3H

Standard Specifications

- Heavy Duty Service — ANSI/(NFPA) T3.6.7R2 - 1996 Specifications and Mounting Dimension Standards
- Standard Construction — Square Head – Tie Rod Design
- Nominal Pressure — 3000 psi¹
- Standard Fluid — Hydraulic Oil
- Standard Temperature — -10°F to +165°F²
- Piston Rod Diameter — 3.000" through 5.500"

In line with our policy of continuing product improvement, specifications in this catalog are subject to change.

- Mounting Styles — 16 standard styles at various application ratings
- Strokes — Available in any practical stroke length
- Cushions — Optional at either end or both ends of stroke
- Rod Ends — Four Standard Choices — specials to order

¹ If hydraulic operating pressure exceeds 3000 psi, send application data for engineering evaluation and recommendation. See Section E for actual design factors.

² See Section E for higher temperature service.

Available Mounting Styles

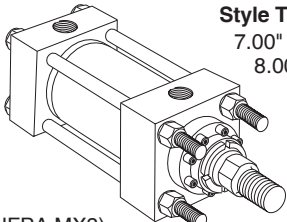
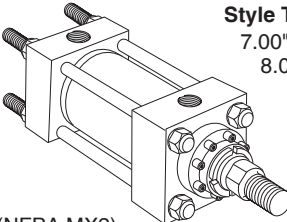
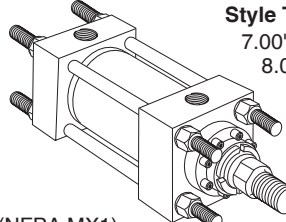
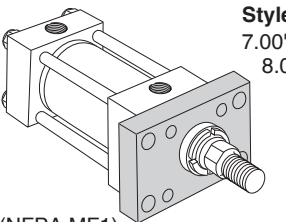
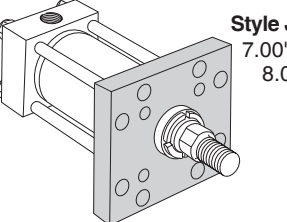
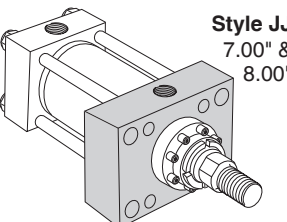
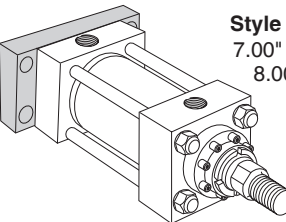
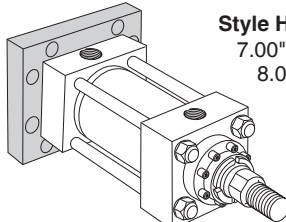
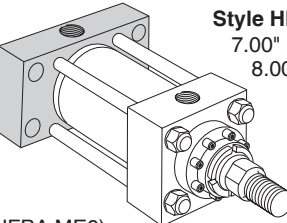
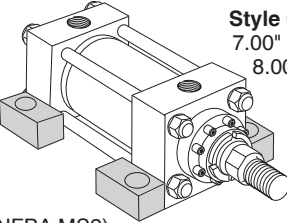
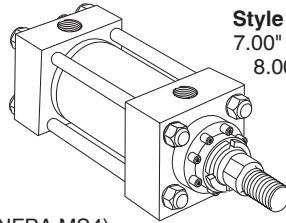
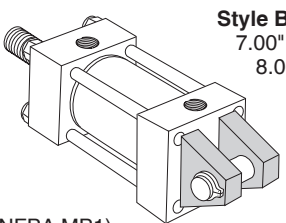
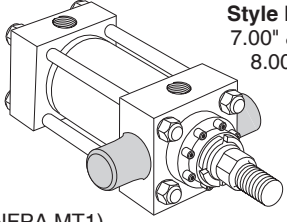
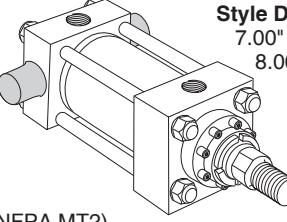
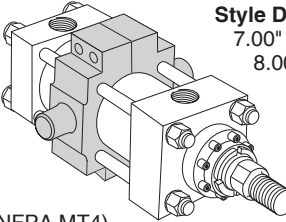
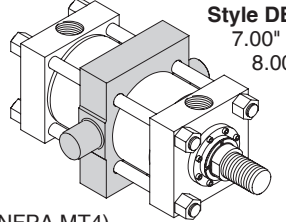
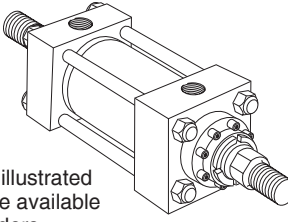
<p>Tie Rods Extended Head End</p>  <p>Style TB 7.00" & 8.00"</p> <p>(NFPA MX3)</p>	<p>Tie Rods Extended Cap End</p>  <p>Style TC 7.00" & 8.00"</p> <p>(NFPA MX2)</p>	<p>Tie Rods Extended Both Ends</p>  <p>Style TD 7.00" & 8.00"</p> <p>(NFPA MX1)</p>	<p>Head Rectangular Flange</p>  <p>Style J 7.00" & 8.00"</p> <p>(NFPA MF1)</p>
<p>Head Square Flange</p>  <p>Style JB 7.00" & 8.00"</p> <p>(NFPA MF5)</p>	<p>Head Rectangular</p>  <p>Style JJ 7.00" & 8.00"</p> <p>(NFPA ME5)</p>	<p>Cap Rectangular Flange</p>  <p>Style H 7.00" & 8.00"</p> <p>(NFPA MF2)</p>	<p>Cap Square Flange</p>  <p>Style HB 7.00" & 8.00"</p> <p>(NFPA MF6)</p>
<p>Cap Rectangular</p>  <p>Style HH 7.00" & 8.00"</p> <p>(NFPA ME6)</p>	<p>Side Lug</p>  <p>Style C 7.00" & 8.00"</p> <p>(NFPA MS2)</p>	<p>Side Tapped</p>  <p>Style F 7.00" & 8.00"</p> <p>(NFPA MS4)</p>	<p>Cap Fixed Clevis</p>  <p>Style BB 7.00" & 8.00"</p> <p>(NFPA MP1)</p>
<p>Head Trunnion</p>  <p>Style D 7.00" & 8.00"</p> <p>(NFPA MT1)</p>	<p>Cap Trunnion</p>  <p>Style DB 7.00" & 8.00"</p> <p>(NFPA MT2)</p>	<p>Intermediate Fixed Trunnion</p>  <p>Style DD 7.00" & 8.00"</p> <p>(NFPA MT4)</p>	<p>HD Intermediate Trunnion Mount</p>  <p>Style DE¹ 7.00" & 8.00"</p> <p>(NFPA MT4)</p>
<p>Double Rod Cylinders</p>  <p>Style KT Shown</p>			

Most of the above illustrated mounting styles are available in double rod cylinders.

¹Style DE Mount conforms to NFPA MT4 dimensional standard.
NOTE: Series 3H Hydraulic Cylinders fully meet ANSI/(NFPA) T3.6.7R2 - 1996 Specifications and Mounting Dimension Standards for Square Head Industrial Fluidpower Cylinders.

Standard Specifications

- Heavy Duty Service
- Standard Construction – Square Head – Tie Rod Design
- Nominal Pressure – 3000 psi¹
- Standard Fluid – Hydraulic Oil
- Standard Temperature – -10°F to +165°F²
- Bore Sizes – 10.00" through 20.00" (Larger sizes available)
- Piston Rod Diameter – 4.500" through 10.000"
- Mounting Styles – 12 standard styles at various application ratings
- Strokes – Available in any practical stroke length
- Cushions – Optional at either end or both ends of stroke
- Rod Ends – Three Standard Choices – Specials to Order

¹ If hydraulic operating pressure exceeds 3000 psi, send application data for engineering evaluation and recommendation. See Section E for actual design factors.

² See Section E for higher temperature service.

In line with our policy of continuing product improvement, specifications in this catalog are subject to change.

Available Mounting Styles

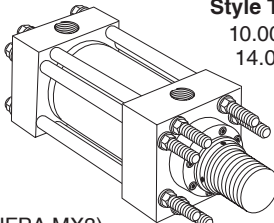
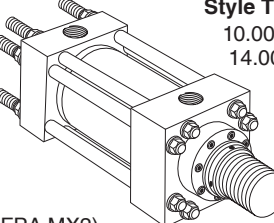
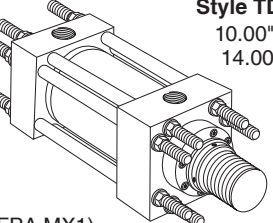
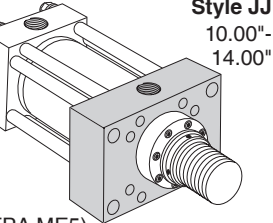
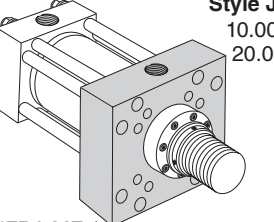
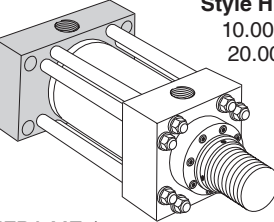
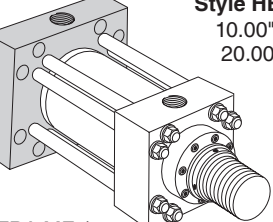
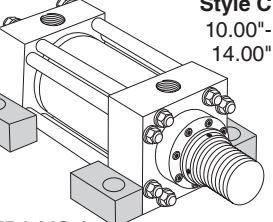
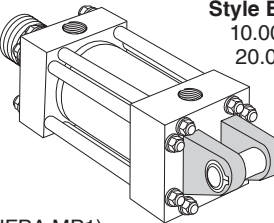
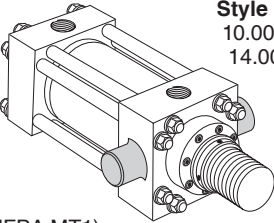
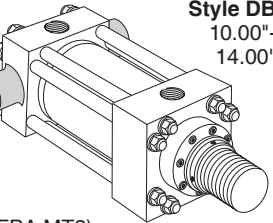
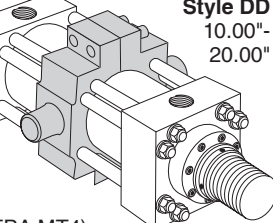
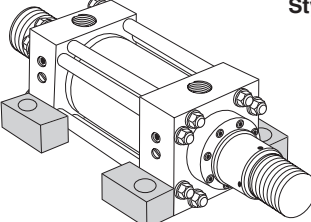
<p>Tie Rods Extended Head End</p>  <p>Style TB 10.00"-14.00"</p> <p>(NFPA MX3)</p>	<p>Tie Rods Extended Cap End</p>  <p>Style TC 10.00"-14.00"</p> <p>(NFPA MX2)</p>	<p>Tie Rods Extended Both Ends</p>  <p>Style TD 10.00"-14.00"</p> <p>(NFPA MX1)</p>	<p>Head Rectangular</p>  <p>Style JJ 10.00"-14.00"</p> <p>(NFPA ME5)</p>
<p>Head Square Flange</p>  <p>Style JB 10.00"-20.00"</p> <p>(NFPA MF5)</p>	<p>Cap Rectangular</p>  <p>Style HH 10.00"-20.00"</p> <p>(NFPA ME6)</p>	<p>Cap Square Flange</p>  <p>Style HB 10.00"-20.00"</p> <p>(NFPA MF6)</p>	<p>Side Lug</p>  <p>Style C 10.00"-14.00"</p> <p>(NFPA MS2)</p>
<p>Cap Fixed Clevis</p>  <p>Style BB 10.00"-20.00"</p> <p>(NFPA MP1)</p>	<p>Head Trunnion</p>  <p>Style D 10.00"-14.00"</p> <p>(NFPA MT1)</p>	<p>Cap Trunnion</p>  <p>Style DB 10.00"-14.00"</p> <p>(NFPA MT2)</p>	<p>Intermediate Fixed Trunnion</p>  <p>Style DD 10.00"-20.00"</p> <p>(NFPA MT4)</p>
<p>Double Rod Cylinders</p>  <p>Style KC Shown</p> <p>Most of the above illustrated mounting styles are available in double rod cylinders.</p>			



3H Model Code

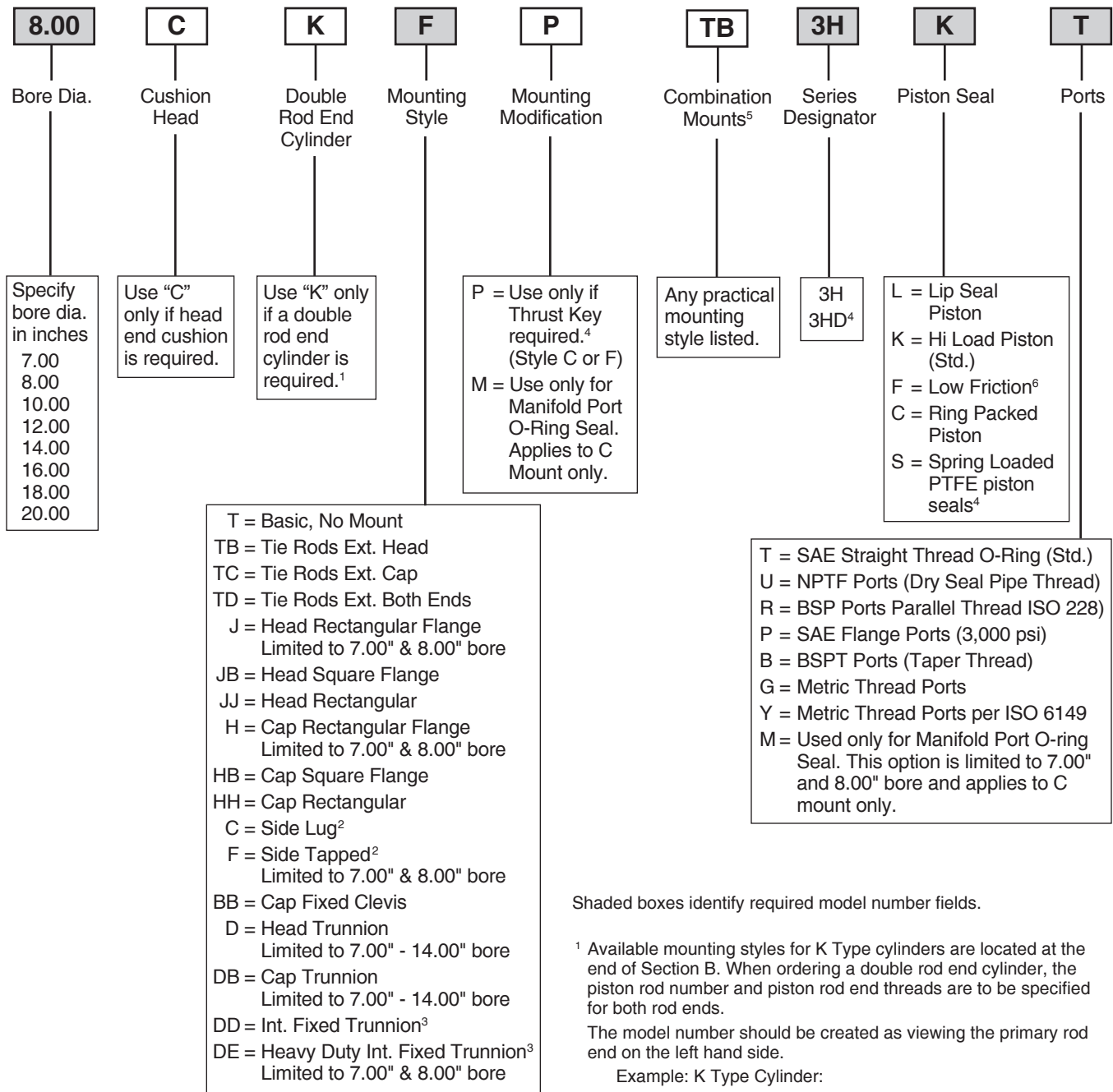

Shaded boxes identify required model number fields.

¹ Available mounting styles for K Type cylinders are located at the end of Section B. When ordering a double rod end cylinder, the piston rod number and piston rod end threads are to be specified for both rod ends.

The model number should be created as viewing the primary rod end on the left hand side.

Example: K Type Cylinder:
7.00CKTD3HLT14A28AC10.000

² Mounting Styles C and F should have a minimum stroke length equal to or greater than their bore size.

³ Specify XI dimension.

⁴ Limited to 7.00" and 8.00" bore.

⁵ In general, the model numbers as read left to right corresponding to the cylinder as viewed from left to right with the primary end at the left. The second or subsequent mountings are mountings called out as they appear in the assembly moving away from the rod end. Except when tie rod extension mountings are part of a combination, all combinations should have a "S" (Special) in the model code and a note in the body of the order clarifying the mounting arrangement. The "P", as used to define a thrust key is not considered to be a mounting. However it is located at the primary end.

⁶ Low Friction Piston Seal limited to 7.00" and 8.00" bore.

3H Model Code

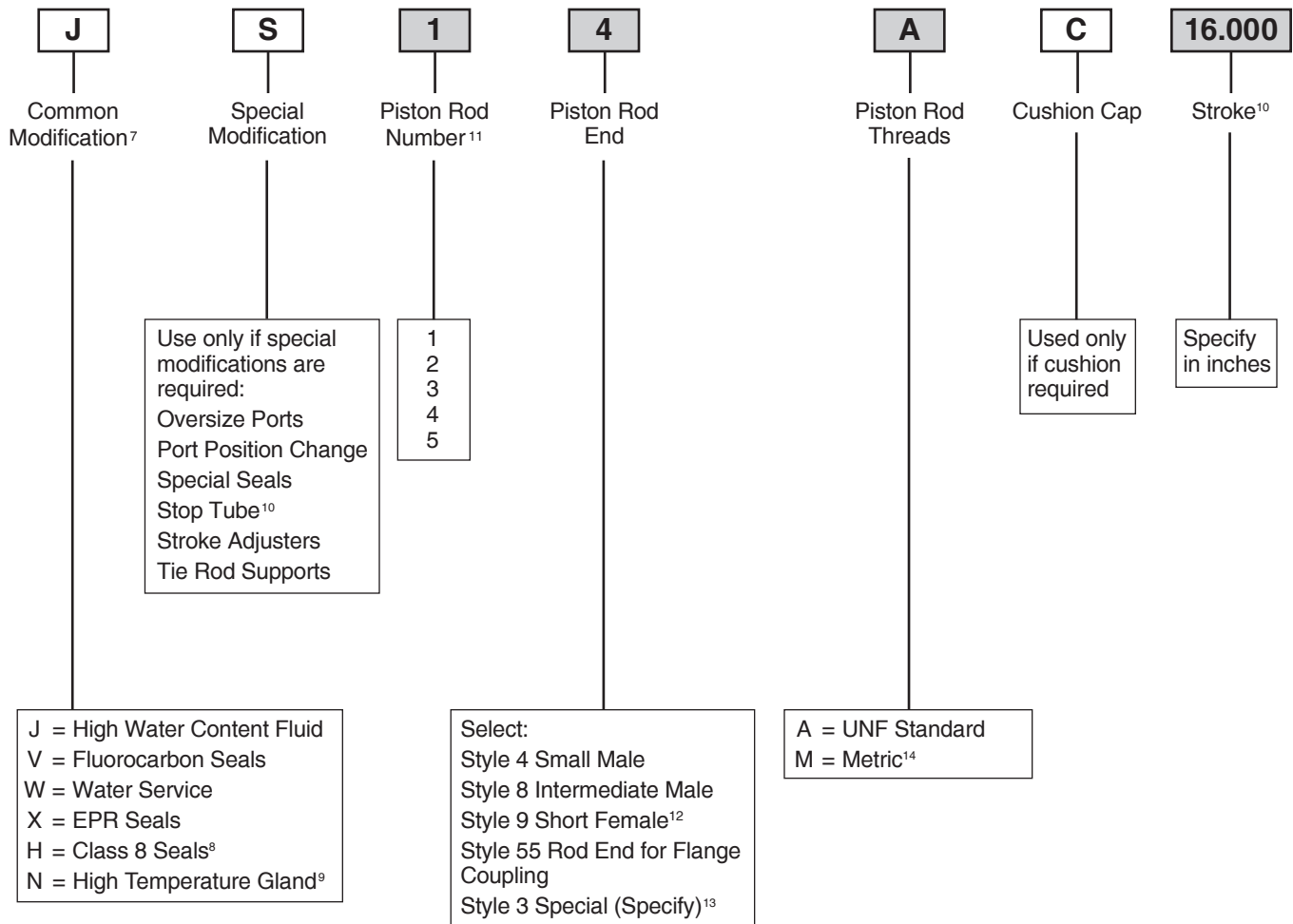

Shaded boxes identify required model number fields.

⁷ See common modifications Section D for additional options.

⁸ Class 8 seal option limited to 7.00" & 8.00" bore cylinders.

⁹ Energized PTFE rod seals & wiperseal are limited to rod sizes of 5.500" and smaller in 7.00" & 8.00" bore size. All other cylinder seals are fluorocarbon.

¹⁰ S = Stop Tube. Specify: stop tube length, net stroke and gross stroke. Gross stroke = stop tube length + net stroke. Gross stroke to be placed in the model number field.

Example:

2.000 inches long stop tube
 +14.000 inches net stroke
 16.000 inches gross stroke

¹¹ Refer to Rod buckling chart in Section E to assure rod number selected will not buckle under load.

¹² Style 9 stroke restrictions may apply. See Style 9 minimum stroke table for details.

¹³ Provide dimensions for KK, A, W or WF. If otherwise special, furnish dimensioned sketch.

¹⁴ See Section D for detailed information regarding standard metric rod end thread sizes.

Style 9 Minimum Stroke Table

Bore Ø	Rod Ø	Minimum Stroke	Bore Ø	Rod Ø	Minimum Stroke
7.00	3.000	1.250	12.00	5.500	1.250
	3.500	1.500		7.000	2.375
	4.000	1.500		8.000	1.125
	5.000	3.125	14.00	7.000	2.000
8.00	3.500	1.500		8.000	2.750
	4.000	1.500	10.000	4.250	
	5.000	2.875	16.00	8.000	1.750
5.500	3.625	9.000		2.500	
10.00	4.500	1.125	18.00	9.000	1.500
	5.000	1.375		10.000	2.250
	5.500	2.000	20.00	10.000	1.250
	7.000	3.125			

Rod End Dimensions – 7.00" and 8.00" Bore

**Thread Style 4 (NFPA Style SM)
Small Male**

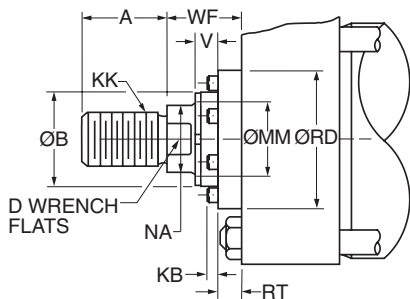

**Thread Style 8 (NFPA Style IM)
Intermediate Male**

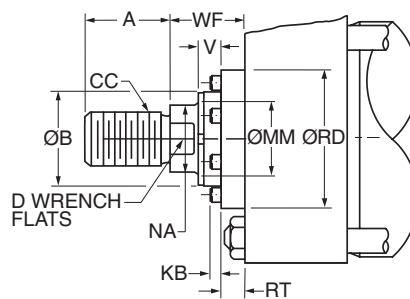

**Thread Style 9² (NFPA Style SF)
Small Female**

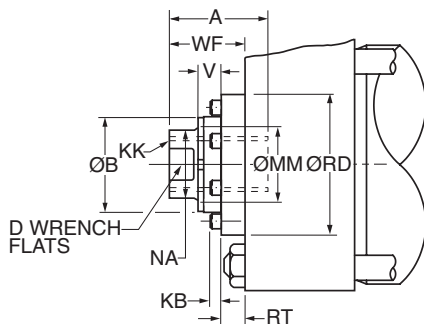

Thread Style 55¹

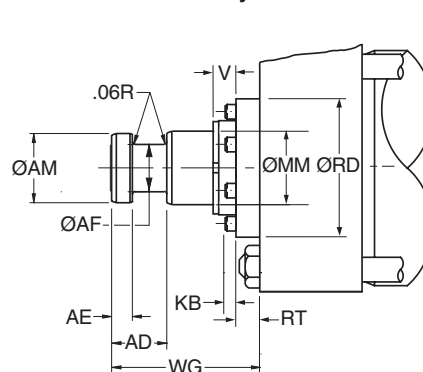

Rod End Dimensions – 7.00" & 8.00" Bore

Bore Ø	Rod No.	MM Rod Ø	Thread		Rod Extensions and Pilot Dimensions								
			Style 8 CC	Style 4 & 9 KK	A	B Ø +.000 -0.002	D	KB	NA	V	RD Ø	RT	WF
7.00	1 (std.)	3.000	2 3/4-12	2 1/4-12	3.50	3.749	2.63	0.250	2.88	0.63	5.25	0.63	2.25
	2	5.000	4 3/4-12	3 1/2-12	5.00	5.749	⁻³	0.000	4.88	0.25	7.25	1.00	2.25
	3	3.500	3 1/4-12	2 1/2-12	3.50	4.249	3.00	0.250	3.38	0.63	5.75	0.63	2.25
	4	4.000	3 3/4-12	3-12	4.00	4.749	3.38	0.250	3.88	0.50	6.50	0.75	2.25
	5	4.500	4 1/4-12	3 1/4-12	4.50	5.249	⁻³	0.250	4.38	0.50	7.00	0.75	2.25
8.00	1 (std.)	3.500	3 1/4-12	2 1/2-12	3.50	4.249	3.00	0.250	3.38	0.63	5.75	0.63	2.25
	2	5.500	5 1/4-12	4-12	5.50	6.249	⁻³	0.000	5.38	0.25	8.25	1.00	2.25
	3	4.000	3 3/4-12	3-12	4.00	4.749	3.38	0.250	3.88	0.50	6.50	0.75	2.25
	4	4.500	4 1/4-12	3 1/4-12	4.50	5.249	⁻³	0.250	4.38	0.50	7.00	0.75	2.25
	5	5.000	4 3/4-12	3 1/2-12	5.00	5.749	⁻³	0.000	4.88	0.25	7.25	1.00	2.25

“Special” Thread Style 3

Special thread, extension, rod eye, blank, etc., are also available.

To order, specify “Style 3” and give desired dimensions for KK, A, W or WF. If otherwise special, furnish dimensioned sketch.

¹ For special WG dimension, specify “Style 3” and give desired dimension for WG. For other changes, place “S” in the model code, and describe rod end with dimensioned sketch.

² Style 9 stroke restrictions may apply. See Style 9 Minimum Stroke Table on How to Order page for details.

³ These piston rod numbers will have 4 spanner wrench holes instead of wrench flats. See rod drawings on next page for dimensions.

Style 55 Rod End

MM Rod Ø	AD	AE +.001 -0.001	AF Ø	AM Ø	WG ¹
3.000	2.44	0.874	2.25	2.95	4.88
3.500	2.69	0.999	2.50	3.45	5.63
4.000	2.69	0.999	3.00	3.95	5.75
4.500	3.19	1.499	3.50	4.45	6.50
5.000	3.19	1.499	3.88	4.95	6.63
5.500	3.94	1.874	4.38	5.45	7.50

Rod End Dimensions – 10.00" - 20.00" Bore

**Thread Style 4 (NFPA Style SM)
Small Male**

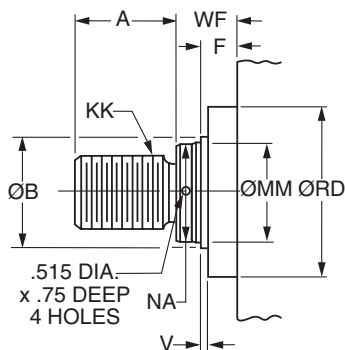

**Thread Style 55¹
Flanged Rod End**

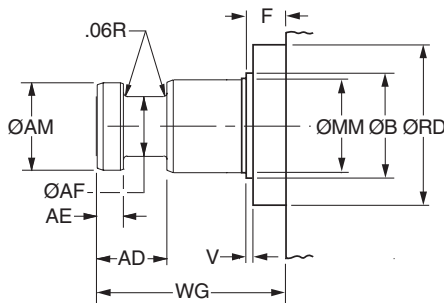

**Thread Style 9² (NFPA Style SF)
Small Female**

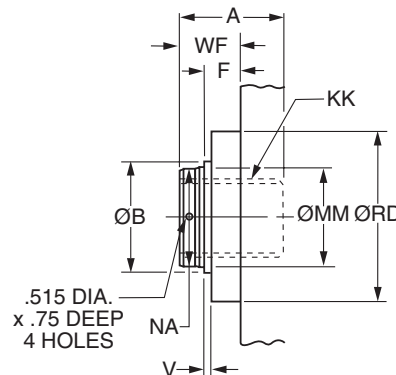

Rod End Dimensions – 10.00" - 20.00" Bore

Bore Ø	Rod No.	MM Rod Ø	Thread Style 4 & 9 KK	Rod Extensions and Pilot Dimensions						
				A	B Ø +.000 - .005	F	NA	RD	V	WF
10.00	1 (std.)	4.500	3 1/4-12	4.50	5.249	1.94	4.38	8.25	0.25	2.94
	2	7.000	5-12	7.00	7.999	1.94	6.88	10.50	0.38	3.50
	3	5.000	3 1/2-12	5.00	5.749	1.94	4.88	8.88	0.25	3.19
	4	5.500	4-12	5.50	6.249	1.94	5.38	9.38	0.25	3.19
12.00	1 (std.)	5.500	4-12	5.50	6.249	1.94	5.38	9.38	0.25	3.19
	2	8.000	5 3/4-12	8.00	8.999	1.94	7.88	12.50	0.38	4.00
	3	7.000	5-12	7.00	7.999	1.94	6.88	10.50	0.38	3.50
14.00	1 (std.)	7.000	5-12	7.00	7.999	1.94	6.88	10.50	0.38	3.50
	2	10.000	7 1/4-12	10.00	10.999	1.94	9.88	14.50	0.38	4.50
	3	8.000	5 3/4-12	8.00	8.999	1.94	7.88	12.50	0.38	4.00
16.00	1	8.000	5 3/4-12	8.00	8.999	1.94	7.88	12.50	0.38	4.00
	3	9.000	6 1/2-12	9.00	9.999	1.94	8.88	13.50	0.38	4.25
	4	10.000	7 1/4-12	10.00	10.999	1.94	9.88	14.50	0.38	4.50
18.00	1	9.000	6 1/2-12	9.00	9.999	1.94	8.88	13.50	0.38	4.25
	3	10.000	7 1/4-12	10.00	10.999	1.94	9.88	14.50	0.38	4.50
20.00	1	10.000	7 1/4-12	10.00	10.999	1.94	9.88	14.50	0.38	4.50

“Special” Thread Style 3

Special thread, extension, rod eye, blank, etc., are also available.

To order, specify “Style 3” and give desired dimensions for KK, A, W or WF. If otherwise special, furnish dimensioned sketch.

¹ For special WG dimension, specify “Style 3” and give desired dimension for WG. For other changes, place “S” in the model code, and describe rod end with dimensioned sketch.

² Style 9 stroke restrictions may apply. See Style 9 Minimum Stroke Table on How to Order page for details.

Style 55 Rod End

MM Rod Ø	AD	AE +.001 - .001	AF Ø	AM Ø	WG ¹
4.500	3.19	1.499	3.50	4.45	6.50
5.000	3.19	1.499	3.88	4.95	6.63
5.500	3.94	1.874	4.38	5.45	7.50
7.000	4.06	1.999	5.75	6.95	8.44
8.000	4.06	1.999	6.50	7.95	8.69
9.000	4.63	2.374	7.25	8.95	8.75
10.000	4.63	2.38	8.00	9.95	9.75



Mounting Information – 7.00" and 8.00" Bore Series 3H

Tie Rods Extended Both Ends
Style TD
 (NFFPA Style MX1)

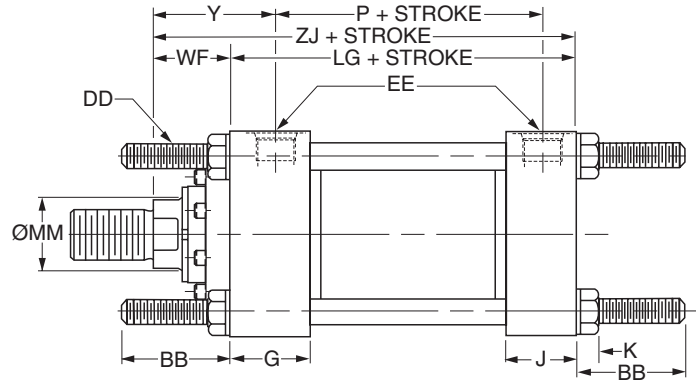
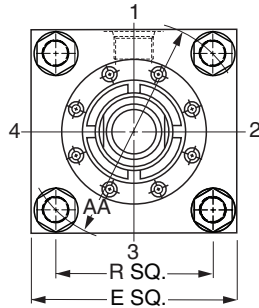
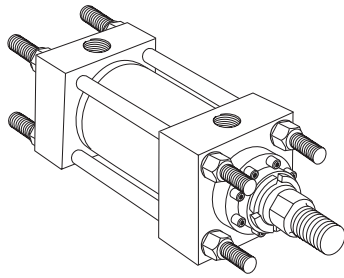

Basic Mounting (T) – NFFPA MXO – Not shown is no tie rod extended and can be supplied upon request.

Table 1 – Dimensional and Mounting Data

Bore Ø	Rod No.	MM Rod Ø	AA	BB	DD	E	EE		G	J	K	R	WF	Y	Add Stroke		
							NPTF ¹	SAE ²							LG	P	ZJ
7.00	1 (std.)	3.000	9.31	4.13	1 1/8-12	8.50	1 1/4	20	2.75	2.75	1.16	6.58	2.25	3.69	8.50	5.63	10.75
	2	5.000	9.31	4.13	1 1/8-12	8.50	1 1/4	20	2.75	2.75	1.16	6.58	2.25	3.69	8.50	5.63	10.75
	3	3.500	9.31	4.13	1 1/8-12	8.50	1 1/4	20	2.75	2.75	1.16	6.58	2.25	3.69	8.50	5.63	10.75
	4	4.000	9.31	4.13	1 1/8-12	8.50	1 1/4	20	2.75	2.75	1.16	6.58	2.25	3.69	8.50	5.63	10.75
	5	4.500	9.31	4.13	1 1/8-12	8.50	1 1/4	20	2.75	2.75	1.16	6.58	2.25	3.69	8.50	5.63	10.75
8.00	1 (std.)	3.500	10.61	4.50	1 1/4-12	9.50	1 1/2	24	3.00	3.00	1.28	7.50	2.25	3.81	9.50	6.38	11.75
	2	5.500	10.61	4.50	1 1/4-12	9.50	1 1/2	24	3.00	3.00	1.28	7.50	2.25	3.81	9.50	6.38	11.75
	3	4.000	10.61	4.50	1 1/4-12	9.50	1 1/2	24	3.00	3.00	1.28	7.50	2.25	3.81	9.50	6.38	11.75
	4	4.500	10.61	4.50	1 1/4-12	9.50	1 1/2	24	3.00	3.00	1.28	7.50	2.25	3.81	9.50	6.38	11.75
	5	5.000	10.61	4.50	1 1/4-12	9.50	1 1/2	24	3.00	3.00	1.28	7.50	2.25	3.81	9.50	6.38	11.75

¹NPTF ports are available at no extra charge.

²SAE straight thread ports are standard and are indicated by port number.

Style TB

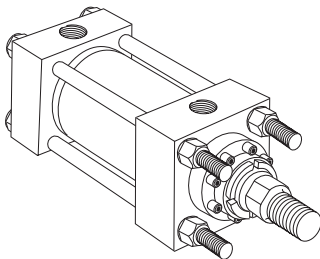

Style TC

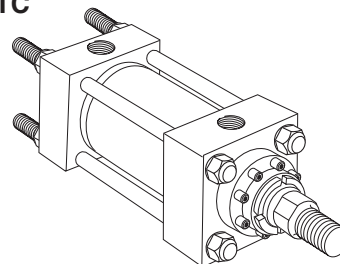

Dimensions for TB and TC Mount may be obtained from the above dimensional table.

Mounting Information – 7.00" and 8.00" Bore Series 3H

Cap Rectangular Flange Mounting
 Style H
 (NFPA Style MF2)

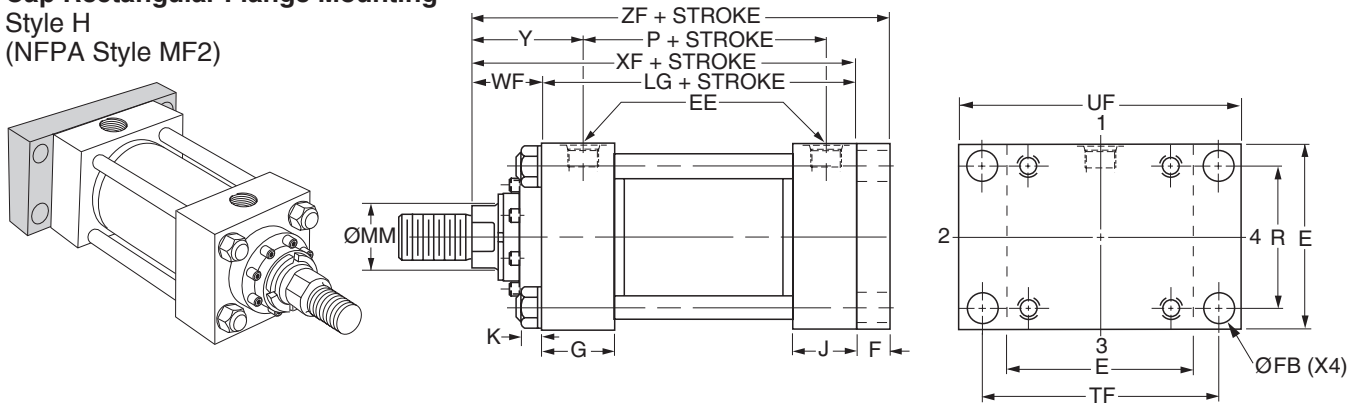

Table 1 – Dimensional and Mounting Data

Bore Ø	Rod No.	MM Rod Ø	E	EE		F	FB Ø	G	J	K	R	TF	UF	WF	Y	Add Stroke			
				NPTF ¹	SAE ²											LG	P	XF	ZF
7.00	1 (std.)	3.000	8.50	1 1/4	20	1.00	1.19	2.75	2.75	1.16	6.58	10.63	12.63	2.25	3.69	8.50	5.63	10.75	11.75
	2	5.000	8.50	1 1/4	20	1.00	1.19	2.75	2.75	1.16	6.58	10.63	12.63	2.25	3.69	8.50	5.63	10.75	11.75
	3	3.500	8.50	1 1/4	20	1.00	1.19	2.75	2.75	1.16	6.58	10.63	12.63	2.25	3.69	8.50	5.63	10.75	11.75
	4	4.000	8.50	1 1/4	20	1.00	1.19	2.75	2.75	1.16	6.58	10.63	12.63	2.25	3.69	8.50	5.63	10.75	11.75
	5	4.500	8.50	1 1/4	20	1.00	1.19	2.75	2.75	1.16	6.58	10.63	12.63	2.25	3.69	8.50	5.63	10.75	11.75
8.00	1 (std.)	3.500	9.50	1 1/2	24	1.00	1.31	3.00	3.00	1.28	7.50	11.81	14.00	2.25	3.81	9.50	6.38	11.75	12.75
	2	5.500	9.50	1 1/2	24	1.00	1.31	3.00	3.00	1.28	7.50	11.81	14.00	2.25	3.81	9.50	6.38	11.75	12.75
	3	4.000	9.50	1 1/2	24	1.00	1.31	3.00	3.00	1.28	7.50	11.81	14.00	2.25	3.81	9.50	6.38	11.75	12.75
	4	4.500	9.50	1 1/2	24	1.00	1.31	3.00	3.00	1.28	7.50	11.81	14.00	2.25	3.81	9.50	6.38	11.75	12.75
	5	5.000	9.50	1 1/2	24	1.00	1.31	3.00	3.00	1.28	7.50	11.81	14.00	2.25	3.81	9.50	6.38	11.75	12.75

¹NPTF ports are available at no extra charge.

²SAE straight thread ports are standard and are indicated by port number.

Table 2 – Maximum Operating Pressure - 3H & 3HD

Bore Ø	Max. psi Pull ³				
	Rod Code				
	1	2	3	4	5
7.00	2000	3000	2000	2500	2800
8.00	1700	2500	1700	1800	2200

³Maximum pressure rating – pull application.



Mounting Information – 7.00" and 8.00" Bore Series 3H

Cap Square Flange Mounting
Style HB
(NFPA Style MF6)

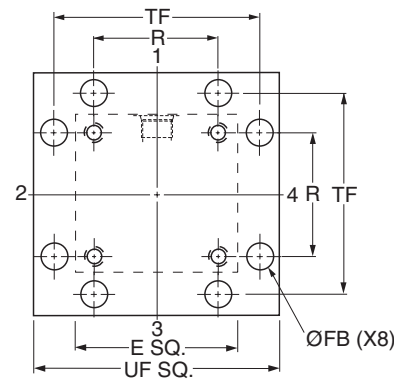
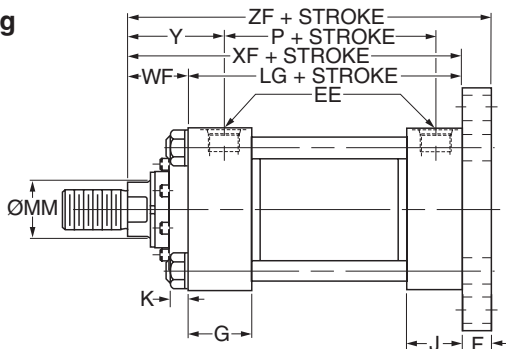
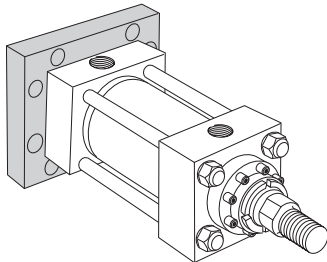

Table 1 – Dimensional and Mounting Data

Bore Ø	Rod No.	MM Rod Ø	E	EE		F	FB Ø	G	J	K	R	TF	UF	WF	Y	Add Stroke			
				NPTF ¹	SAE ²											LG	P	XF	ZF
7.00	1 (std.)	3.000	8.50	1 1/4	20	1.00	1.19	2.75	2.75	1.16	6.58	10.63	12.63	2.25	3.69	8.50	5.63	10.75	11.75
	2	5.000	8.50	1 1/4	20	1.00	1.19	2.75	2.75	1.16	6.58	10.63	12.63	2.25	3.69	8.50	5.63	10.75	11.75
	3	3.500	8.50	1 1/4	20	1.00	1.19	2.75	2.75	1.16	6.58	10.63	12.63	2.25	3.69	8.50	5.63	10.75	11.75
	4	4.000	8.50	1 1/4	20	1.00	1.19	2.75	2.75	1.16	6.58	10.63	12.63	2.25	3.69	8.50	5.63	10.75	11.75
	5	4.500	8.50	1 1/4	20	1.00	1.19	2.75	2.75	1.16	6.58	10.63	12.63	2.25	3.69	8.50	5.63	10.75	11.75
8.00	1 (std.)	3.500	9.50	1 1/2	24	1.00	1.31	3.00	3.00	1.28	7.50	11.81	14.00	2.25	3.81	9.50	6.38	11.75	12.75
	2	5.500	9.50	1 1/2	24	1.00	1.31	3.00	3.00	1.28	7.50	11.81	14.00	2.25	3.81	9.50	6.38	11.75	12.75
	3	4.000	9.50	1 1/2	24	1.00	1.31	3.00	3.00	1.28	7.50	11.81	14.00	2.25	3.81	9.50	6.38	11.75	12.75
	4	4.500	9.50	1 1/2	24	1.00	1.31	3.00	3.00	1.28	7.50	11.81	14.00	2.25	3.81	9.50	6.38	11.75	12.75
	5	5.000	9.50	1 1/2	24	1.00	1.31	3.00	3.00	1.28	7.50	11.81	14.00	2.25	3.81	9.50	6.38	11.75	12.75

¹NPTF ports are available at no extra charge.

²SAE straight thread ports are standard and are indicated by port number.

Cap Rectangular Mounting
Style HH
(NFPA Style ME6)

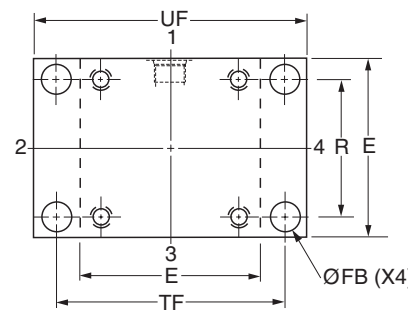
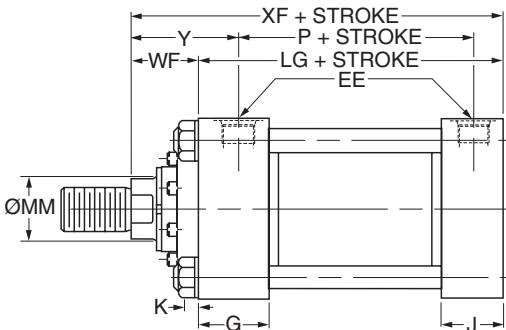
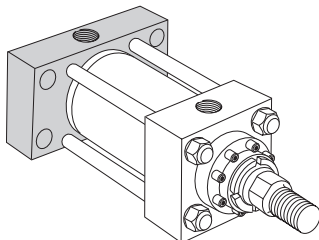

Table 1 – Dimensional and Mounting Data

Bore Ø	Rod No.	MM Rod Ø	E	EE		FB Ø	G	J	K	R	TF	UF	WF	Y	Add Stroke		
				NPTF ¹	SAE ²										LG	P	XF
7.00	1 (std.)	3.000	8.50	1 1/4	20	1.19	2.75	2.75	1.16	6.58	10.63	12.63	2.25	3.69	8.50	5.63	10.75
	2	5.000	8.50	1 1/4	20	1.19	2.75	2.75	1.16	6.58	10.63	12.63	2.25	3.69	8.50	5.63	10.75
	3	3.500	8.50	1 1/4	20	1.19	2.75	2.75	1.16	6.58	10.63	12.63	2.25	3.69	8.50	5.63	10.75
	4	4.000	8.50	1 1/4	20	1.19	2.75	2.75	1.16	6.58	10.63	12.63	2.25	3.69	8.50	5.63	10.75
	5	4.500	8.50	1 1/4	20	1.19	2.75	2.75	1.16	6.58	10.63	12.63	2.25	3.69	8.50	5.63	10.75
8.00	1 (std.)	3.500	9.50	1 1/2	24	1.31	3.00	3.00	1.28	7.50	11.81	14.00	2.25	3.81	9.50	6.38	11.75
	2	5.500	9.50	1 1/2	24	1.31	3.00	3.00	1.28	7.50	11.81	14.00	2.25	3.81	9.50	6.38	11.75
	3	4.000	9.50	1 1/2	24	1.31	3.00	3.00	1.28	7.50	11.81	14.00	2.25	3.81	9.50	6.38	11.75
	4	4.500	9.50	1 1/2	24	1.31	3.00	3.00	1.28	7.50	11.81	14.00	2.25	3.81	9.50	6.38	11.75
	5	5.000	9.50	1 1/2	24	1.31	3.00	3.00	1.28	7.50	11.81	14.00	2.25	3.81	9.50	6.38	11.75

¹NPTF ports are available at no extra charge.

²SAE straight thread ports are standard and are indicated by port number.

Mounting Information – 7.00" and 8.00" Bore Series 3H

Head Rectangular Flange Mounting

Style J
(NFPA Style MF1)

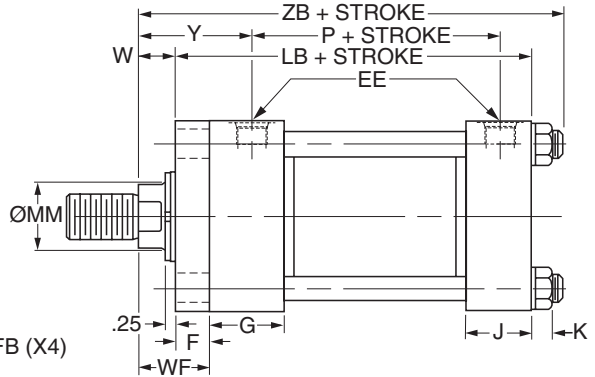
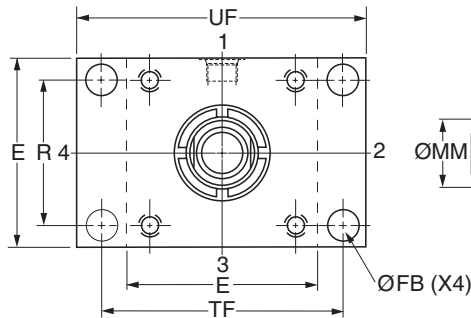
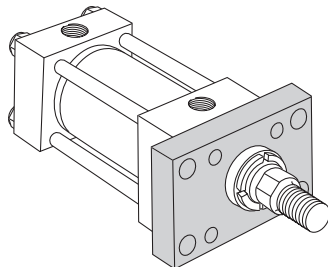

Table 1 – Dimensional and Mounting Data

For pressures exceeding those shown use mounting styles JB or JJ.

Bore Ø	Rod No.	MM Rod Ø	E	EE		F	FB Ø	G	J	K	R	TF	UF	W	WF	Y	Add Stroke		
				NPTF ¹	SAE ²												LB	P	ZB Max.
7.00	1 (std.)	3.000	8.50	1 1/4	20	1.00	1.19	2.75	2.75	1.16	6.58	10.63	12.63	1.25	2.25	3.69	9.50	5.63	12.31
	2	5.000	8.50	1 1/4	20	1.00	1.19	2.75	2.75	1.16	6.58	10.63	12.63	1.25	2.25	3.69	9.50	5.63	12.31
	3	3.500	8.50	1 1/4	20	1.00	1.19	2.75	2.75	1.16	6.58	10.63	12.63	1.25	2.25	3.69	9.50	5.63	12.31
	4	4.000	8.50	1 1/4	20	1.00	1.19	2.75	2.75	1.16	6.58	10.63	12.63	1.25	2.25	3.69	9.50	5.63	12.31
	5	4.500	8.50	1 1/4	20	1.00	1.19	2.75	2.75	1.16	6.58	10.63	12.63	1.25	2.25	3.69	9.50	5.63	12.31
8.00	1 (std.)	3.500	9.50	1 1/2	24	1.00	1.31	3.00	3.00	1.28	7.50	11.81	14.00	1.25	2.25	3.81	10.50	6.38	13.56
	2	5.500	9.50	1 1/2	24	1.00	1.31	3.00	3.00	1.28	7.50	11.81	14.00	1.25	2.25	3.81	10.50	6.38	13.56
	3	4.000	9.50	1 1/2	24	1.00	1.31	3.00	3.00	1.28	7.50	11.81	14.00	1.25	2.25	3.81	10.50	6.38	13.56
	4	4.500	9.50	1 1/2	24	1.00	1.31	3.00	3.00	1.28	7.50	11.81	14.00	1.25	2.25	3.81	10.50	6.38	13.56
	5	5.000	9.50	1 1/2	24	1.00	1.31	3.00	3.00	1.28	7.50	11.81	14.00	1.25	2.25	3.81	10.50	6.38	13.56

¹NPTF ports are available at no extra charge.

²SAE straight thread ports are standard and are indicated by port number.

Table 2 – Maximum Operating Pressure – 3H

Bore Ø	Max. psi Push ³				
	Rod Code				
	1	2	3	4	5
7.00	1400	800	1200	1100	1000
8.00	1100	800	1000	1000	800

³Maximum pressure rating – push application.

Table 3 – Maximum Operating Pressure – 3HD

Bore Ø	Max. psi Push ³				
	Rod Code				
	1	2	3	4	5
7.00	1000	400	800	400	400
8.00	800	400	700	400	400

³Maximum pressure rating – push application.



Mounting Information – 7.00" and 8.00" Bore Series 3H

Head Square Flange Mounting
 Style JB
 (NFPA Style MF5)

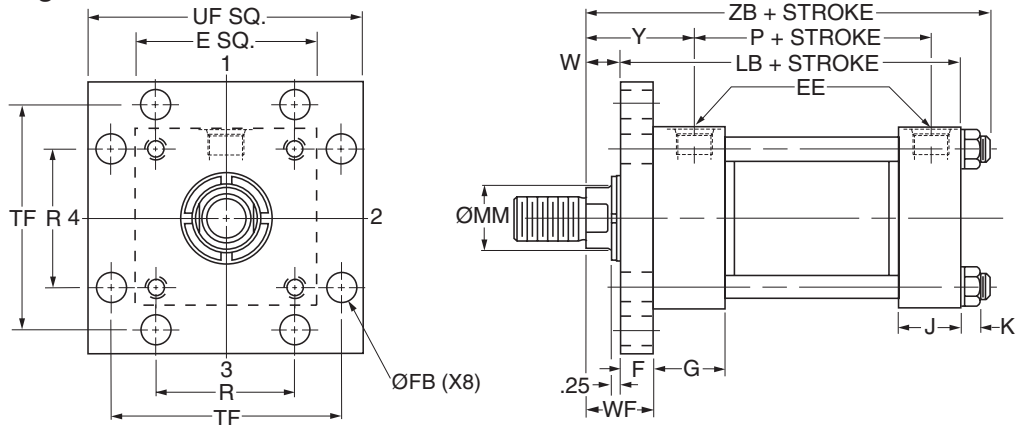
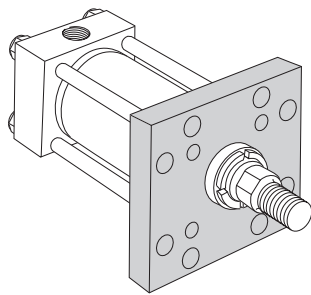

Table 1 – Dimensional and Mounting Data

Bore Ø	Rod No.	MM Rod Ø	E	EE		F	FB Ø	G	J	K	R	TF	UF	W	WF	Y	Add Stroke		
				NPTF ¹	SAE ²												LB	P	ZB Max.
7.00	1 (std.)	3.000	8.50	1 1/4	20	1.00	1.19	2.75	2.75	1.16	6.58	10.63	12.63	1.25	2.25	3.69	9.50	5.63	12.31
	2	5.000	8.50	1 1/4	20	1.00	1.19	2.75	2.75	1.16	6.58	10.63	12.63	1.25	2.25	3.69	9.50	5.63	12.31
	3	3.500	8.50	1 1/4	20	1.00	1.19	2.75	2.75	1.16	6.58	10.63	12.63	1.25	2.25	3.69	9.50	5.63	12.31
	4	4.000	8.50	1 1/4	20	1.00	1.19	2.75	2.75	1.16	6.58	10.63	12.63	1.25	2.25	3.69	9.50	5.63	12.31
	5	4.500	8.50	1 1/4	20	1.00	1.19	2.75	2.75	1.16	6.58	10.63	12.63	1.25	2.25	3.69	9.50	5.63	12.31
8.00	1 (std.)	3.500	9.50	1 1/2	24	1.00	1.31	3.00	3.00	1.28	7.50	11.81	14.00	1.25	2.25	3.81	10.50	6.38	13.56
	2	5.500	9.50	1 1/2	24	1.00	1.31	3.00	3.00	1.28	7.50	11.81	14.00	1.25	2.25	3.81	10.50	6.38	13.56
	3	4.000	9.50	1 1/2	24	1.00	1.31	3.00	3.00	1.28	7.50	11.81	14.00	1.25	2.25	3.81	10.50	6.38	13.56
	4	4.500	9.50	1 1/2	24	1.00	1.31	3.00	3.00	1.28	7.50	11.81	14.00	1.25	2.25	3.81	10.50	6.38	13.56
	5	5.000	9.50	1 1/2	24	1.00	1.31	3.00	3.00	1.28	7.50	11.81	14.00	1.25	2.25	3.81	10.50	6.38	13.56

¹NPTF ports are available at no extra charge.

²SAE straight thread ports are standard and are indicated by port number.

Table 2 – Maximum Operating Pressure – 3H

Bore Ø	Max. psi Push ³				
	Rod Code				
	1	2	3	4	5
7.00	3000	2700	3000	3000	3000
8.00	3000	2300	2500	2500	2500

³Maximum pressure rating – push application.

Table 3 – Maximum Operating Pressure – 3HD

Bore Ø	Max. psi Push ³				
	Rod Code				
	1	2	3	4	5
7.00	2500	1500	2200	1500	1500
8.00	2000	1400	2000	1400	1400

³Maximum pressure rating – push application.

Mounting Information – 7.00" and 8.00" Bore Series 3H

Head Rectangular Mounting
 Style JJ
 (NFA Style ME5)

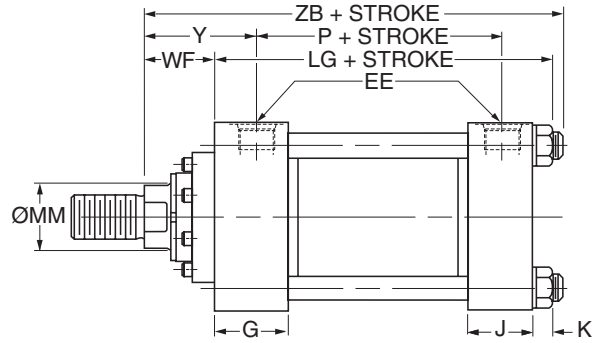
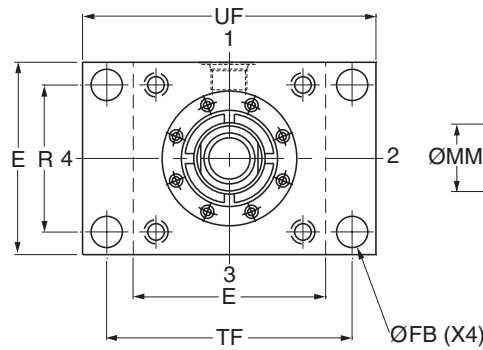
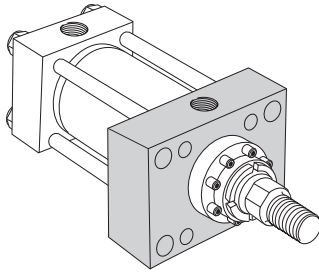

Table 1 – Dimensional and Mounting Data

Bore Ø	Rod No.	MM Rod Ø	E	EE		FB Ø	G	J	K	R	TF	UF	WF	Y	Add Stroke		
				NPTF ¹	SAE ²										LG	P	ZB Max.
7.00	1 (std.)	3.000	8.50	1 1/4	20	1.19	2.75	2.75	1.16	6.58	10.63	12.63	2.25	3.69	8.50	5.63	12.31
	2	5.000	8.50	1 1/4	20	1.19	2.75	2.75	1.16	6.58	10.63	12.63	2.25	3.69	8.50	5.63	12.31
	3	3.500	8.50	1 1/4	20	1.19	2.75	2.75	1.16	6.58	10.63	12.63	2.25	3.69	8.50	5.63	12.31
	4	4.000	8.50	1 1/4	20	1.19	2.75	2.75	1.16	6.58	10.63	12.63	2.25	3.69	8.50	5.63	12.31
	5	4.500	8.50	1 1/4	20	1.19	2.75	2.75	1.16	6.58	10.63	12.63	2.25	3.69	8.50	5.63	12.31
8.00	1 (std.)	3.500	9.50	1 1/2	24	1.31	3.00	3.00	1.28	7.50	11.81	14.00	2.25	3.81	9.50	6.38	13.56
	2	5.500	9.50	1 1/2	24	1.31	3.00	3.00	1.28	7.50	11.81	14.00	2.25	3.81	9.50	6.38	13.56
	3	4.000	9.50	1 1/2	24	1.31	3.00	3.00	1.28	7.50	11.81	14.00	2.25	3.81	9.50	6.38	13.56
	4	4.500	9.50	1 1/2	24	1.31	3.00	3.00	1.28	7.50	11.81	14.00	2.25	3.81	9.50	6.38	13.56
	5	5.000	9.50	1 1/2	24	1.31	3.00	3.00	1.28	7.50	11.81	14.00	2.25	3.81	9.50	6.38	13.56

¹NPTF ports are available at no extra charge.

²SAE straight thread ports are standard and are indicated by port number.



Mounting Information – 7.00" and 8.00" Bore Series 3H

**Side Lug Mounting
Style C
(NFPA Style MS2)**

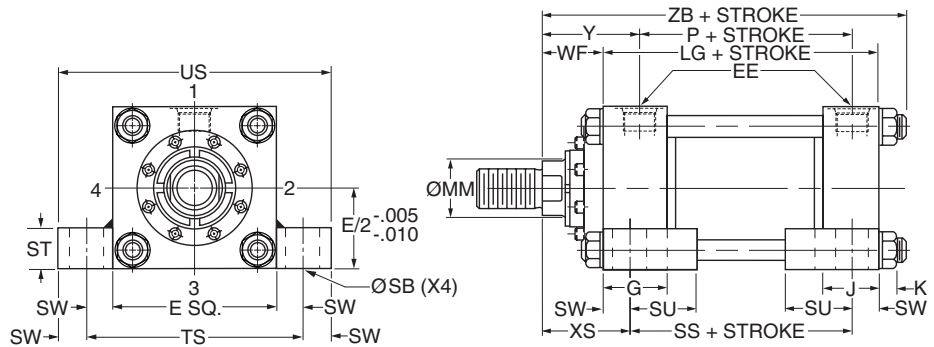
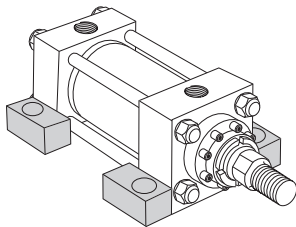

Table 1 – Dimensional and Mounting Data

Bore Ø	Rod No.	MM Rod Ø	E	EE		G	J	K	SB Ø	ST	SU	SW	TS	US	WF	XS	Y	Add Stroke			
				NPTF ¹	SAE ²													LG	P	SS	ZB Max.
7.00	1 (std.)	3.000	8.50	1 1/4	20	2.75	2.75	1.16	1.56	1.75	2.88	1.38	11.25	14.00	2.25	3.63	3.69	8.50	5.63	5.75	12.31
	2	5.000	8.50	1 1/4	20	2.75	2.75	1.16	1.56	1.75	2.88	1.38	11.25	14.00	2.25	3.63	3.69	8.50	5.63	5.75	12.31
	3	3.500	8.50	1 1/4	20	2.75	2.75	1.16	1.56	1.75	2.88	1.38	11.25	14.00	2.25	3.63	3.69	8.50	5.63	5.75	12.31
	4	4.000	8.50	1 1/4	20	2.75	2.75	1.16	1.56	1.75	2.88	1.38	11.25	14.00	2.25	3.63	3.69	8.50	5.63	5.75	12.31
	5	4.500	8.50	1 1/4	20	2.75	2.75	1.16	1.56	1.75	2.88	1.38	11.25	14.00	2.25	3.63	3.69	8.50	5.63	5.75	12.31
8.00	1 (std.)	3.500	9.50	1 1/2	24	3.00	3.00	1.28	1.56	1.75	2.88	1.38	12.25	15.00	2.25	3.63	3.81	9.50	6.38	6.75	13.56
	2	5.500	9.50	1 1/2	24	3.00	3.00	1.28	1.56	1.75	2.88	1.38	12.25	15.00	2.25	3.63	3.81	9.50	6.38	6.75	13.56
	3	4.000	9.50	1 1/2	24	3.00	3.00	1.28	1.56	1.75	2.88	1.38	12.25	15.00	2.25	3.63	3.81	9.50	6.38	6.75	13.56
	4	4.500	9.50	1 1/2	24	3.00	3.00	1.28	1.56	1.75	2.88	1.38	12.25	15.00	2.25	3.63	3.81	9.50	6.38	6.75	13.56
	5	5.000	9.50	1 1/2	24	3.00	3.00	1.28	1.56	1.75	2.88	1.38	12.25	15.00	2.25	3.63	3.81	9.50	6.38	6.75	13.56

¹NPTF ports are available at no extra charge.

²SAE straight thread ports are standard and are indicated by port number.

**Side Tapped Mounting
Style F
(NFPA Style MS4)**

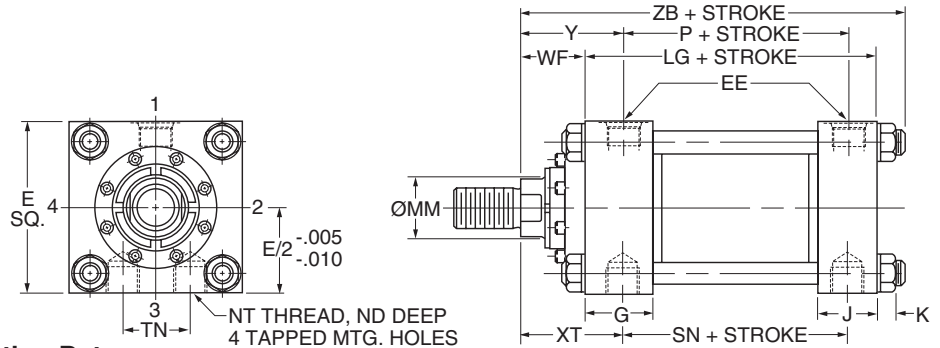
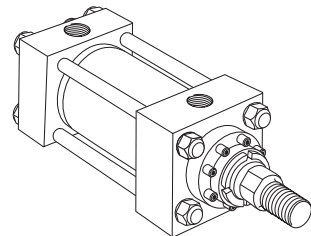

Table 1 – Dimensional and Mounting Data

Bore Ø	Rod No.	MM Rod Ø	E	EE		G	J	K	ND	NT	TN	WF	XT	Y	Add Stroke			
				NPTF ¹	SAE ²										LG	P	SN	ZB Max.
7.00	1 (std.)	3.000	8.50	1 1/4	20	2.75	2.75	1.16	1.13	1 1/2-6	3.75	2.25	3.81	3.69	8.50	5.63	5.88	12.31
	2	5.000	8.50	1 1/4	20	2.75	2.75	1.16	1.13	1 1/2-6	3.75	2.25	3.81	3.69	8.50	5.63	5.88	12.31
	3	3.500	8.50	1 1/4	20	2.75	2.75	1.16	1.13	1 1/2-6	3.75	2.25	3.81	3.69	8.50	5.63	5.88	12.31
	4	4.000	8.50	1 1/4	20	2.75	2.75	1.16	1.13	1 1/2-6	3.75	2.25	3.81	3.69	8.50	5.63	5.88	12.31
	5	4.500	8.50	1 1/4	20	2.75	2.75	1.16	1.13	1 1/2-6	3.75	2.25	3.81	3.69	8.50	5.63	5.88	12.31
8.00	1 (std.)	3.500	9.50	1 1/2	24	3.00	3.00	1.28	1.50	1 1/2-6	4.25	2.25	3.94	3.81	9.50	6.38	6.63	13.56
	2	5.500	9.50	1 1/2	24	3.00	3.00	1.28	1.50	1 1/2-6	4.25	2.25	3.94	3.81	9.50	6.38	6.63	13.56
	3	4.000	9.50	1 1/2	24	3.00	3.00	1.28	1.50	1 1/2-6	4.25	2.25	3.94	3.81	9.50	6.38	6.63	13.56
	4	4.500	9.50	1 1/2	24	3.00	3.00	1.28	1.50	1 1/2-6	4.25	2.25	3.94	3.81	9.50	6.38	6.63	13.56
	5	5.000	9.50	1 1/2	24	3.00	3.00	1.28	1.50	1 1/2-6	4.25	2.25	3.94	3.81	9.50	6.38	6.63	13.56

¹NPTF ports are available at no extra charge.

²SAE straight thread ports are standard and are indicated by port number.



Mounting Information – 7.00" and 8.00" Bore Series 3H

**Cap Fixed Clevis Mounting
Style BB
(NFPA Style MP1)**

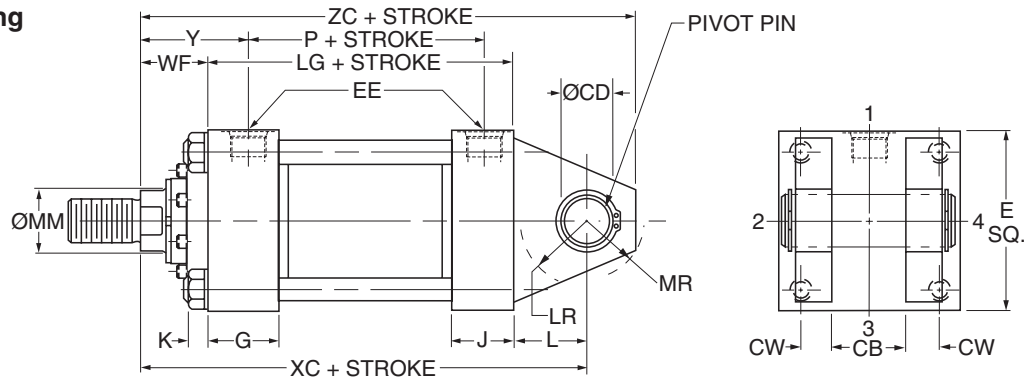
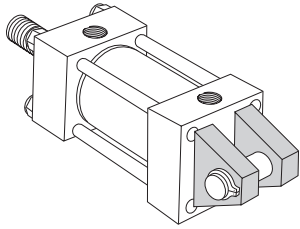

Table 1 – Dimensional and Mounting Data

Bore Ø	Rod No.	MM Rod Ø	CB	CD ³ Ø +0.000 -0.002	CW	E	EE		G	J	K	L	LR	MR	WF	Y
							NPTF ¹	SAE ²								
7.00	1 (std.)	3.000	3.00	2.501	1.50	8.50	1 1/4	20	2.75	2.75	1.16	3.00	2.75	2.88	2.25	3.69
	2	5.000	3.00	2.501	1.50	8.50	1 1/4	20	2.75	2.75	1.16	3.00	2.75	2.88	2.25	3.69
	3	3.500	3.00	2.501	1.50	8.50	1 1/4	20	2.75	2.75	1.16	3.00	2.75	2.88	2.25	3.69
	4	4.000	3.00	2.501	1.50	8.50	1 1/4	20	2.75	2.75	1.16	3.00	2.75	2.88	2.25	3.69
	5	4.500	3.00	2.501	1.50	8.50	1 1/4	20	2.75	2.75	1.16	3.00	2.75	2.88	2.25	3.69
8.00	1 (std.)	3.500	3.00	3.001	1.50	9.50	1 1/2	24	3.00	3.00	1.28	3.25	3.25	3.13	2.25	3.81
	2	5.500	3.00	3.001	1.50	9.50	1 1/2	24	3.00	3.00	1.28	3.25	3.25	3.13	2.25	3.81
	3	4.000	3.00	3.001	1.50	9.50	1 1/2	24	3.00	3.00	1.28	3.25	3.25	3.13	2.25	3.81
	4	4.500	3.00	3.001	1.50	9.50	1 1/2	24	3.00	3.00	1.28	3.25	3.25	3.13	2.25	3.81
	5	5.000	3.00	3.001	1.50	9.50	1 1/2	24	3.00	3.00	1.28	3.25	3.25	3.13	2.25	3.81

¹NPTF ports are available at no extra charge.

²SAE straight thread ports are standard and are indicated by port number.

³Dimension CD is pin diameter.

Table 2 – Dimensional and Mounting Data

Bore Ø	Rod No.	MM Rod Ø	WF	Add Stroke			
				LG	P	XC	ZC
7.00	1 (std.)	3.000	2.25	8.50	5.63	13.75	16.25
	2	5.000	2.25	8.50	5.63	13.75	16.25
	3	3.500	2.25	8.50	5.63	13.75	16.25
	4	4.000	2.25	8.50	5.63	13.75	16.25
	5	4.500	2.25	8.50	5.63	13.75	16.25
8.00	1 (std.)	3.500	2.25	9.50	6.38	15.00	17.75
	2	5.500	2.25	9.50	6.38	15.00	17.75
	3	4.000	2.25	9.50	6.38	15.00	17.75
	4	4.500	2.25	9.50	6.38	15.00	17.75
	5	5.000	2.25	9.50	6.38	15.00	17.75



Mounting Information – 7.00" and 8.00" Bore Series 3H

Head Trunnion Mounting
Style D
(NFPA Style MT1)

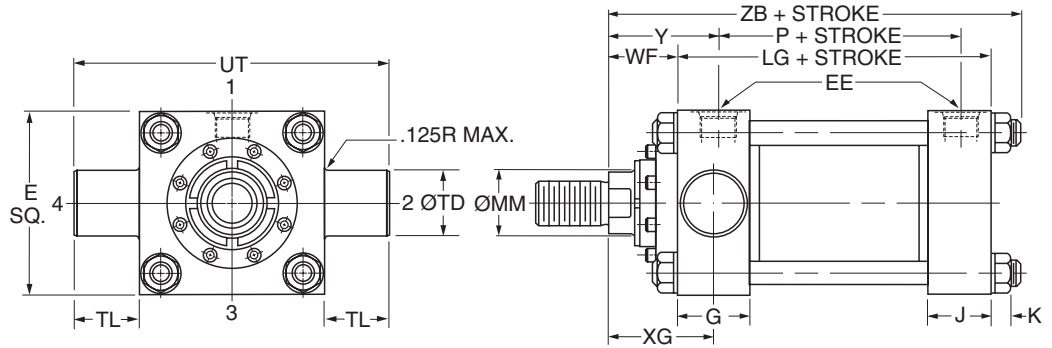
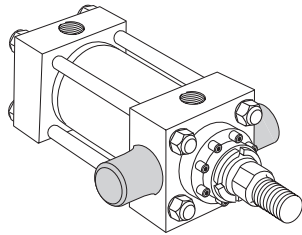

Table 1 – Dimensional and Mounting Data

Bore Ø	Rod No.	MM Rod Ø	E	EE		G	J	K	TD Ø +0.000 -0.002	TL	UT	WF	Y	XG
				NPTF ¹	SAE ²									
7.00	1 (std.)	3.000	8.50	1 1/4	20	2.75	2.75	1.16	2.500	2.50	13.50	2.25	3.69	3.63
	2	5.000	8.50	1 1/4	20	2.75	2.75	1.16	2.500	2.50	13.50	2.25	3.69	3.63
	3	3.500	8.50	1 1/4	20	2.75	2.75	1.16	2.500	2.50	13.50	2.25	3.69	3.63
	4	4.000	8.50	1 1/4	20	2.75	2.75	1.16	2.500	2.50	13.50	2.25	3.69	3.63
	5	4.500	8.50	1 1/4	20	2.75	2.75	1.16	2.500	2.50	13.50	2.25	3.69	3.63
8.00	1 (std.)	3.500	9.50	1 1/2	24	3.00	3.00	1.28	3.000	3.00	15.50	2.25	3.81	3.75
	2	5.500	9.50	1 1/2	24	3.00	3.00	1.28	3.000	3.00	15.50	2.25	3.81	3.75
	3	4.000	9.50	1 1/2	24	3.00	3.00	1.28	3.000	3.00	15.50	2.25	3.81	3.75
	4	4.500	9.50	1 1/2	24	3.00	3.00	1.28	3.000	3.00	15.50	2.25	3.81	3.75
	5	5.000	9.50	1 1/2	24	3.00	3.00	1.28	3.000	3.00	15.50	2.25	3.81	3.75

¹NPTF ports are available at no extra charge.

²SAE straight thread ports are standard and are indicated by port number.

Table 2 – Dimensional and Mounting Data

Bore Ø	Rod No.	MM Rod Ø	Add Stroke		
			LG	P	ZB Max.
7.00	1 (std.)	3.000	8.50	5.63	12.31
	2	5.000	8.50	5.63	12.31
	3	3.500	8.50	5.63	12.31
	4	4.000	8.50	5.63	12.31
	5	4.500	8.50	5.63	12.31
8.00	1 (std.)	3.500	9.50	6.38	13.56
	2	5.500	9.50	6.38	13.56
	3	4.000	9.50	6.38	13.56
	4	4.500	9.50	6.38	13.56
	5	5.000	9.50	6.38	13.56

Mounting Information – 7.00" and 8.00" Bore Series 3H

Cap Trunnion Mounting
Style DB
(NFPA Style MT2)

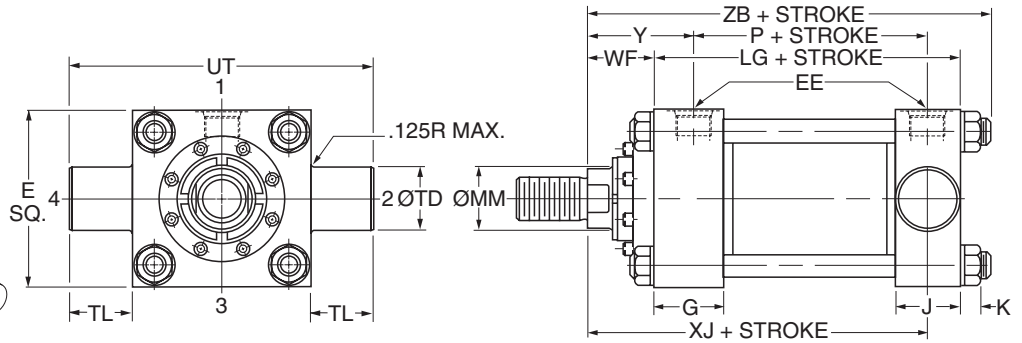
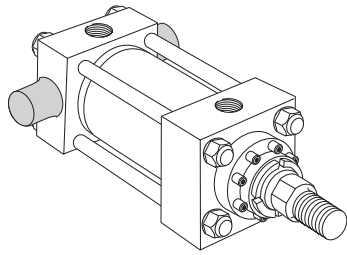

Table 1 – Dimensional and Mounting Data

Bore Ø	Rod No.	MM Rod Ø	E	EE		G	J	K	TD Ø +0.000 -0.002	TL	UT	WF	Y
				NPTF ¹	SAE ²								
7.00	1 (std.)	3.000	8.50	1 1/4	20	2.75	2.75	1.16	2.500	2.50	13.50	2.25	3.69
	2	5.000	8.50	1 1/4	20	2.75	2.75	1.16	2.500	2.50	13.50	2.25	3.69
	3	3.500	8.50	1 1/4	20	2.75	2.75	1.16	2.500	2.50	13.50	2.25	3.69
	4	4.000	8.50	1 1/4	20	2.75	2.75	1.16	2.500	2.50	13.50	2.25	3.69
	5	4.500	8.50	1 1/4	20	2.75	2.75	1.16	2.500	2.50	13.50	2.25	3.69
8.00	1 (std.)	3.500	9.50	1 1/2	24	3.00	3.00	1.28	3.000	3.00	15.50	2.25	3.81
	2	5.500	9.50	1 1/2	24	3.00	3.00	1.28	3.000	3.00	15.50	2.25	3.81
	3	4.000	9.50	1 1/2	24	3.00	3.00	1.28	3.000	3.00	15.50	2.25	3.81
	4	4.500	9.50	1 1/2	24	3.00	3.00	1.28	3.000	3.00	15.50	2.25	3.81
	5	5.000	9.50	1 1/2	24	3.00	3.00	1.28	3.000	3.00	15.50	2.25	3.81

¹NPTF ports are available at no extra charge.

²SAE straight thread ports are standard and are indicated by port number.

Table 2 – Dimensional and Mounting Data

Bore Ø	Rod No.	MM Rod Ø	Add Stroke			
			LG	P	XJ	ZB Max
7.00	1 (std.)	3.000	8.50	5.63	9.38	12.31
	2	5.000	8.50	5.63	9.38	12.31
	3	3.500	8.50	5.63	9.38	12.31
	4	4.000	8.50	5.63	9.38	12.31
	5	4.500	8.50	5.63	9.38	12.31
8.00	1 (std.)	3.500	9.50	6.38	10.25	13.56
	2	5.500	9.50	6.38	10.25	13.56
	3	4.000	9.50	6.38	10.25	13.56
	4	4.500	9.50	6.38	10.25	13.56
	5	5.000	9.50	6.38	10.25	13.56



Mounting Information – 7.00" and 8.00" Bore Series 3H

Intermediate Fixed Trunnion Mounting
Style DD
 (NFPA Former Standard Style MT4)

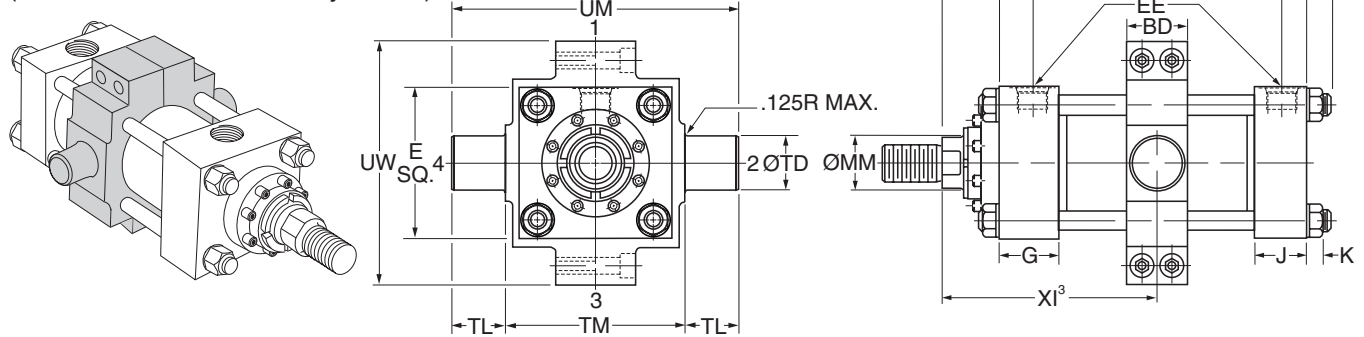

Table 1 – Dimensional and Mounting Data

Bore Ø	Rod No.	MM Rod Ø	BD	E	EE		G	J	K	TD Ø +0.000 -0.002	TL	TM	UM	UW	WF	Y	Min. XI ³
					NPTF ¹	SAE ²											
7.00	1 (std.)	3.000	3.00	8.50	1 1/4	20	2.75	2.75	1.16	2.500	2.50	9.75	14.75	11.50	2.25	3.69	6.56
	2	5.000	3.00	8.50	1 1/4	20	2.75	2.75	1.16	2.500	2.50	9.75	14.75	11.50	2.25	3.69	6.56
	3	3.500	3.00	8.50	1 1/4	20	2.75	2.75	1.16	2.500	2.50	9.75	14.75	11.50	2.25	3.69	6.56
	4	4.000	3.00	8.50	1 1/4	20	2.75	2.75	1.16	2.500	2.50	9.75	14.75	11.50	2.25	3.69	6.56
	5	4.500	3.00	8.50	1 1/4	20	2.75	2.75	1.16	2.500	2.50	9.75	14.75	11.50	2.25	3.69	6.56
8.00	1 (std.)	3.500	3.50	9.50	1 1/2	24	3.00	3.00	1.28	3.000	3.00	11.00	17.00	13.38	2.25	3.81	7.06
	2	5.500	3.50	9.50	1 1/2	24	3.00	3.00	1.28	3.000	3.00	11.00	17.00	13.38	2.25	3.81	7.06
	3	4.000	3.50	9.50	1 1/2	24	3.00	3.00	1.28	3.000	3.00	11.00	17.00	13.38	2.25	3.81	7.06
	4	4.500	3.50	9.50	1 1/2	24	3.00	3.00	1.28	3.000	3.00	11.00	17.00	13.38	2.25	3.81	7.06
	5	5.000	3.50	9.50	1 1/2	24	3.00	3.00	1.28	3.000	3.00	11.00	17.00	13.38	2.25	3.81	7.06

¹NPTF ports are available at no extra charge.

²SAE straight thread ports are standard and are indicated by port number.

³Dimension XI to be specified by customer.

Table 2 – Dimensional and Mounting Data

Bore Ø	Rod No.	MM Rod Ø	Style DD Minimum Stroke	Add Stroke		
				LG	P	ZB Max.
7.00	1 (std.)	3.000	0.13	8.50	5.63	12.31
	2	5.000	0.13	8.50	5.63	12.31
	3	3.500	0.13	8.50	5.63	12.31
	4	4.000	0.13	8.50	5.63	12.31
	5	4.500	0.13	8.50	5.63	12.31
8.00	1 (std.)	3.500	0.13	9.50	6.38	13.56
	2	5.500	0.13	9.50	6.38	13.56
	3	4.000	0.13	9.50	6.38	13.56
	4	4.500	0.13	9.50	6.38	13.56
	5	5.000	0.13	9.50	6.38	13.56

Mounting Information – 7.00" and 8.00" Bore Series 3H

Heavy Duty Intermediate Fixed Trunnion Mounting
Style DE
 (NFPA Current Standard Style MT4)

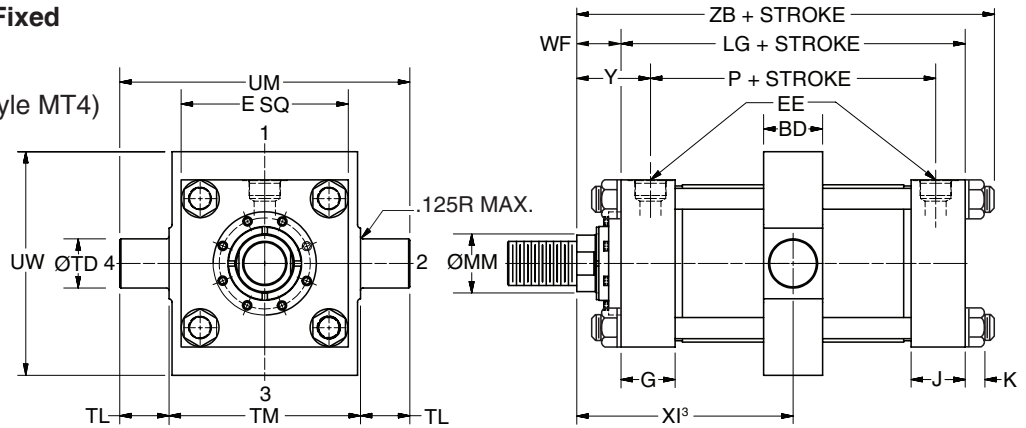
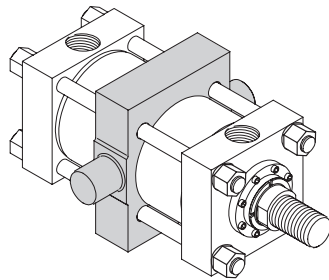

Table 1 – Dimensional and Mounting Data

Bore Ø	Rod No.	MM Rod Ø	BD	E	EE		G	J	K	TD Ø +.000 -.002	TL	TM	UM	UW	WF	Y	Min XI ³
					NPTF ¹	SAE ²											
7.00	1 (std.)	3.000	4.000	8.50	1 1/4	20	2.75	2.75	1.16	3.500	2.50	9.75	14.75	11.38	2.25	3.69	7.06
	2	5.000	4.000	8.50	1 1/4	20	2.75	2.75	1.16	3.500	2.50	9.75	14.75	11.38	2.25	3.69	7.06
	3	3.500	4.000	8.50	1 1/4	20	2.75	2.75	1.16	3.500	2.50	9.75	14.75	11.38	2.25	3.69	7.06
	4	4.000	4.000	8.50	1 1/4	20	2.75	2.75	1.16	3.500	2.50	9.75	14.75	11.38	2.25	3.69	7.06
	5	4.500	4.000	8.50	1 1/4	20	2.75	2.75	1.16	3.500	2.50	9.75	14.75	11.38	2.25	3.69	7.06
8.00	1 (std.)	3.500	4.500	9.50	1 1/2	24	3.00	3.00	1.28	4.000	3.00	11.00	17.00	12.00	2.25	3.81	7.56
	2	5.500	4.500	9.50	1 1/2	24	3.00	3.00	1.28	4.000	3.00	11.00	17.00	12.00	2.25	3.81	7.56
	3	4.000	4.500	9.50	1 1/2	24	3.00	3.00	1.28	4.000	3.00	11.00	17.00	12.00	2.25	3.81	7.56
	4	4.500	4.500	9.50	1 1/2	24	3.00	3.00	1.28	4.000	3.00	11.00	17.00	12.00	2.25	3.81	7.56
	5	5.000	4.500	9.50	1 1/2	24	3.00	3.00	1.28	4.000	3.00	11.00	17.00	12.00	2.25	3.81	7.56

¹NPTF ports are available at no extra charge.

²SAE straight thread ports are standard and are indicated by port number.

³Dimension XI to be specified by customer.

Table 2 – Dimensional and Mounting Data

Bore Ø	Rod No.	MM Rod Ø	Style DE Minimum Stroke	Add Stroke		
				LG	P	ZB Max.
7.00	1 (std.)	3.000	1.13	8.50	5.63	12.31
	2	5.000	1.13	8.50	5.63	12.31
	3	3.500	1.13	8.50	5.63	12.31
	4	4.000	1.13	8.50	5.63	12.31
	5	4.500	1.13	8.50	5.63	12.31
8.00	1 (std.)	3.500	1.13	9.50	6.38	13.56
	2	5.500	1.13	9.50	6.38	13.56
	3	4.000	1.13	9.50	6.38	13.56
	4	4.500	1.13	9.50	6.38	13.56
	5	5.000	1.13	9.50	6.38	13.56



Double Rod Models – 7.00" and 8.00" Bore

Double Rod Cylinder
Style K

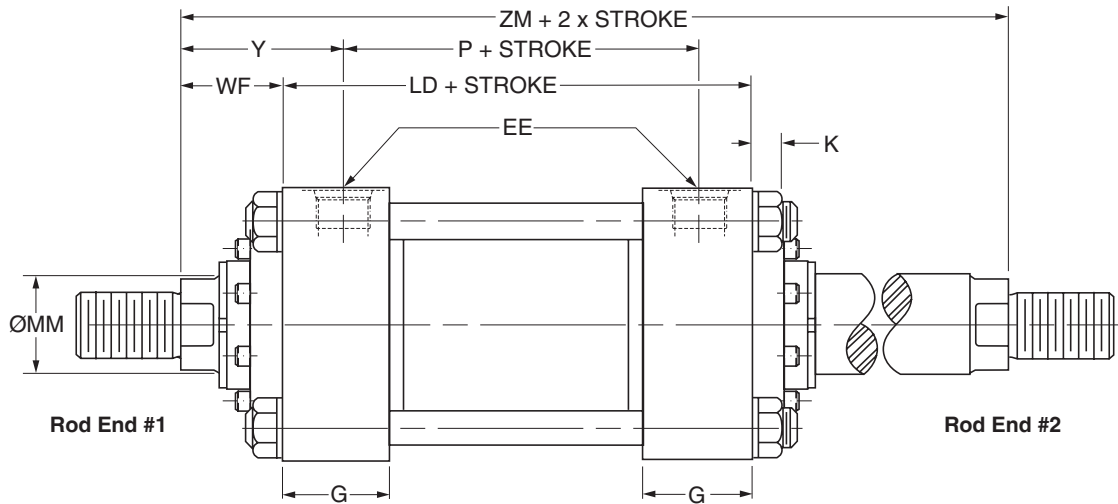

Mounting Styles for Single Rod Models	Mounting Styles for Corresponding Double Rod Models ¹	Dimensions Shown on This Page Supplement Dimensions on Pages Listed Below for 7.00" - 8.00" Bores
TB	KTB	40
TD	KTD	40
J	KJ	43
JB	KJB	44
JJ	KJJ	45
C	KC	46
F	KF	46
D	KD	48
DD	KDD ²	50
DE	KDE ²	51

¹ If only one end of these Double Rod Cylinders is to be cushioned, be sure to specify clearly which end this will be.

² Specify XI dimension from rod end #1.

Bore Ø	Rod No.	MM Rod Ø	WF	Add Stroke			Add 2X Stroke
				LD	SNK	SSK	ZM
7.00	1 (std.)	3.00	2.25	8.50	5.38	5.75	13.00
	2	5.00	2.25	8.50	5.38	5.75	13.00
	3	3.50	2.25	8.50	5.38	5.75	13.00
	4	4.00	2.25	8.50	5.38	5.75	13.00
	5	4.50	2.25	8.50	5.38	5.75	13.00
8.00	1 (std.)	3.50	2.25	9.50	6.13	6.75	14.00
	2	5.50	2.25	9.50	6.13	6.75	14.00
	3	4.00	2.25	9.50	6.13	6.75	14.00
	4	4.50	2.25	9.50	6.13	6.75	14.00
	5	5.00	2.25	9.50	6.13	6.75	14.00
Replaces On single rod mounting styles:				LB	SN	SS	-
				All Mtg. Styles	F	C	All Mtg. Styles

How to Use Double Rod Cylinder
Dimension Drawings

To determine dimensions for a double rod cylinder, first refer to the desired single rod mounting style cylinder shown on preceding pages of this catalog. (See table above.) After selecting necessary dimensions from that drawing, return to this page supplement the single rod dimensions with those shown on drawing at right and dimension table below. Note that double rod cylinders have a head (Dim. G) at both ends and that dimension LD replaces LB. The double rod dimensions differ from, or are in addition to those for single

rod cylinders shown on preceding pages and provide the information needed to completely dimension a double rod cylinder.

On a double rod cylinder where the two rod ends are different, be sure to clearly state which rod end is to be assembled at which end. Port position 1 is standard. If other than standard, specify pos. 2, 3 or 4 when viewed from rod end #1 only. See port position information in Section E.

Tie Rods Extended Both Ends Mounting
Style TD
(NFPA Style MX1)

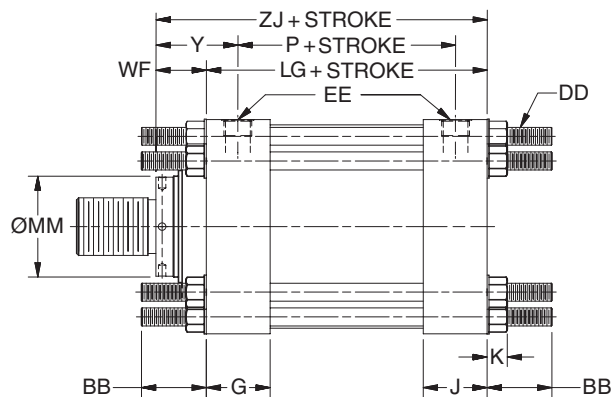
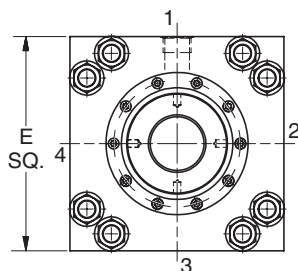
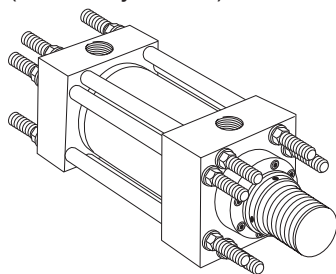

Table 1 – Dimensional and Mounting Data

Bore Ø	Rod No.	MM Rod Ø	BB	DD	E	EE			G	J	K	WF	Y	Add Stroke		
						NPTF ¹	SAE Flange Ports ²	SAE Straight Thread ³						LG	P	ZJ
10.00	1 (std.)	4.500	4.13	1 1/8-12	12.63	2.00	2.00	24	3.69	3.69	1.28	2.94	4.75	12.13	8.50	15.06
	2	7.000	4.13	1 1/8-12	12.63	2.00	2.00	24	3.69	3.69	1.28	3.50	5.31	12.13	8.50	15.63
	3	5.000	4.13	1 1/8-12	12.63	2.00	2.00	24	3.69	3.69	1.28	3.19	5.00	12.13	8.50	15.31
	4	5.500	4.13	1 1/8-12	12.63	2.00	2.00	24	3.69	3.69	1.28	3.19	5.00	12.13	8.50	15.31
12.00	1 (std.)	5.500	4.50	1 1/4-12	14.88	2.50	2.50	24	4.44	4.44	1.41	3.19	5.38	14.50	10.13	17.69
	2	8.000	4.50	1 1/4-12	14.88	2.50	2.50	24	4.44	4.44	1.41	4.00	6.19	14.50	10.13	18.50
	3	7.000	4.50	1 1/4-12	14.88	2.50	2.50	24	4.44	4.44	1.41	3.50	5.69	14.50	10.13	18.00
14.00	1 (std.)	7.000	4.50	1 1/4-12	17.13	2.50	2.50	24	4.88	4.88	1.41	3.50	5.88	15.63	10.88	19.13
	2	10.000	4.50	1 1/4-12	17.13	2.50	2.50	24	4.88	4.88	1.41	4.50	6.88	15.63	10.88	20.13
	3	8.000	4.50	1 1/4-12	17.13	2.50	2.50	24	4.88	4.88	1.41	4.00	6.38	15.63	10.88	19.63

¹NPTF ports are available at no extra charge.

²Optional SAE flange ports may be specified – flange to be supplied by customer. See Table 2 for flange port pattern dimensions.

³SAE straight thread ports are standard and are indicated by port number.

Table 2 – Optional SAE Flange Port Pattern

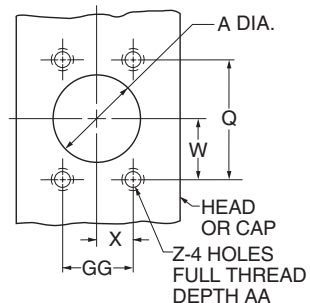

Nom. Flange Size	A	Q	GG	W	X	Z-THD UNC-2B	AA Min.	SAE
2	2.00	3.062	1.688	1.53	0.84	1/2-13	1.06	32
2 1/2	2.50	3.500	2.000	1.75	1.00	1/2-13	1.19	40

Table 3 – Tie Rod Information

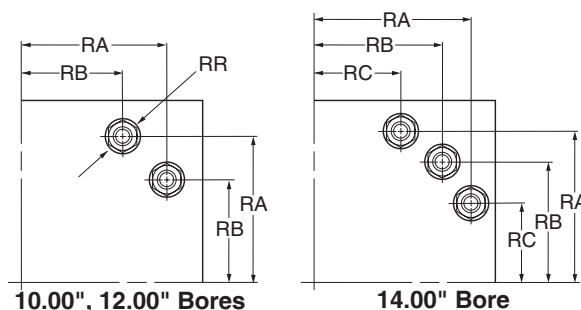

Bore Ø	10.00	12.00	14.00
Tie Rod Thread	1 1/8-12	1 1/4-12	1 1/4-12
RA	5.291	6.270	7.485
RB	3.775	4.555	6.143
RC	—	—	4.409
RR	2.13	2.38	2.25

Style TB

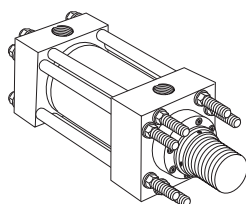

Style TC

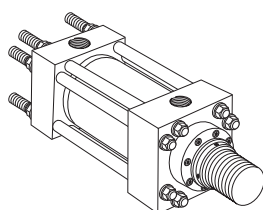

Dimensions for TB and TC Mount may be obtained from the above dimensional table.



Head Rectangular Mounting
Style JJ (10"-14" Bore)
(NFPA Style ME5)

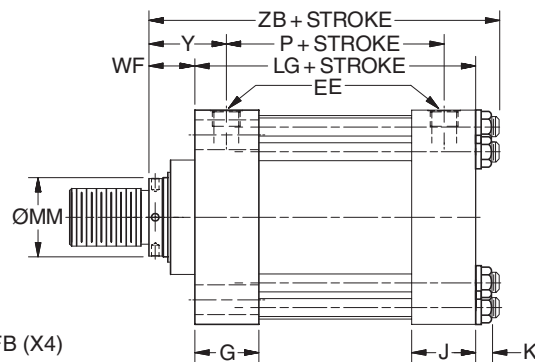
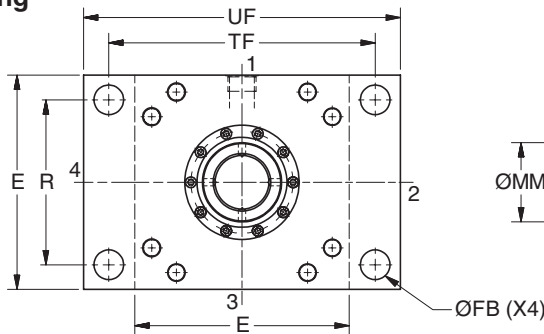
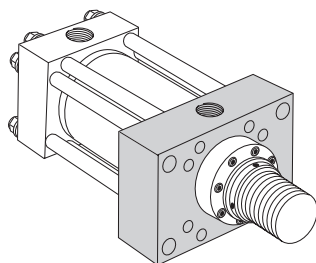

Table 1 – Dimensional and Mounting Data

Bore Ø	Rod No.	MM Rod Ø	E	Ports (EE)			FB Ø	G	J	K	R	TF	UF	WF	Y	Add Stroke		
				NPTF ¹	SAE Flange Port ²	SAE Straight Thread Port ³										LG	P	ZB Max.
10.00	1 (std.)	4.500	12.63	2.00	2.00	24	1.81	3.69	3.69	1.28	9.62	15.88	19.00	2.94	4.75	12.13	8.50	16.69
	2	7.000	12.63	2.00	2.00	24	1.81	3.69	3.69	1.28	9.62	15.88	19.00	3.50	5.31	12.13	8.50	17.25
	3	5.000	12.63	2.00	2.00	24	1.81	3.69	3.69	1.28	9.62	15.88	19.00	3.19	5.00	12.13	8.50	16.94
	4	5.500	12.63	2.00	2.00	24	1.81	3.69	3.69	1.28	9.62	15.88	19.00	3.19	5.00	12.13	8.50	16.94
12.00	1 (std.)	5.500	14.88	2.50	2.50	24	2.06	4.44	4.44	1.41	11.45	18.50	22.00	3.19	5.38	14.50	10.13	19.44
	2	8.000	14.88	2.50	2.50	24	2.06	4.44	4.44	1.41	11.45	18.50	22.00	4.00	6.19	14.50	10.13	20.25
	3	7.000	14.88	2.50	2.50	24	2.06	4.44	4.44	1.41	11.45	18.50	22.00	3.50	5.69	14.50	10.13	19.75
14.00	1 (std.)	7.000	17.13	2.50	2.50	24	2.31	4.88	4.88	1.41	13.26	21.00	25.00	3.50	5.88	15.63	10.88	20.88
	2	10.000	17.13	2.50	2.50	24	2.31	4.88	4.88	1.41	13.26	21.00	25.00	4.50	6.88	15.63	10.88	21.88
	3	8.000	17.13	2.50	2.50	24	2.31	4.88	4.88	1.41	13.26	21.00	25.00	4.00	6.38	15.63	10.88	21.38

¹NPTF ports are available at no extra charge.

²Optional SAE flange ports may be specified – flange to be supplied by customer. See Table 2 for flange port pattern dimensions.

³SAE straight thread ports are standard and are indicated by port number.

Table 2 – Optional SAE Flange Port Pattern

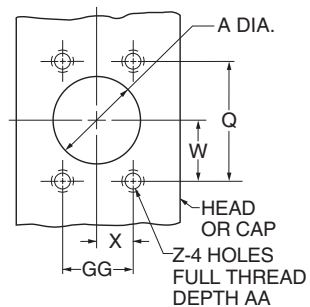

Nom. Flange Size	A	Q	GG	W	X	Z-THD UNC-2B	AA Min.	SAE
2	2.00	3.062	1.688	1.53	0.84	1/2-13	1.06	32
2 1/2	2.50	3.500	2.000	1.75	1.00	1/2-13	1.19	40

Head Rectangular Mounting
Style JJ (16"-20" Bore)
(NFPA Style ME5)

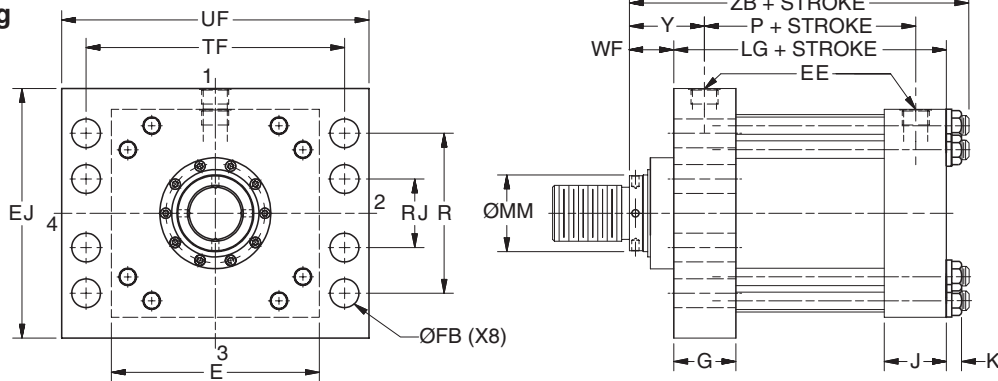
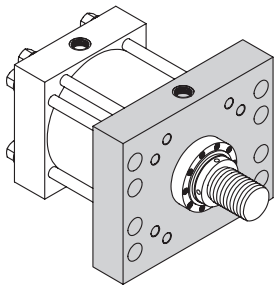

Table 1 – Dimensional and Mounting Data

Bore Ø	Rod No.	MM Rod Ø	E	EJ	Ports (EE)		FB Ø	G	J	K	R	RJ	TF	UF	WF	Y	Add Stroke		
					SAE Flange Port ¹	SAE Straight Thread Port ²											LG	P	ZB Max.
16.00	1 (std.)	8.000	19.00	20.00	3.00	24	1.81	5.88	5.88	1.91	15.50	8.00	21.00	24.50	4.00	7.00	18.13	12.13	24.38
	3	9.000	19.00	20.00	3.00	24	1.81	5.88	5.88	1.91	15.50	8.00	21.00	24.50	4.25	7.25	18.13	12.13	24.63
	4	10.000	19.00	20.00	3.00	24	1.81	5.88	5.88	1.91	15.50	8.00	21.00	24.50	4.50	7.50	18.13	12.13	24.88
18.00	1 (std.)	9.000	22.00	23.00	3.00	24	2.06	6.88	6.88	1.91	18.00	7.25	24.25	28.25	4.25	7.25	21.13	15.13	27.63
	3	10.000	22.00	23.00	3.00	24	2.06	6.88	6.88	1.91	18.00	7.25	24.25	28.25	4.50	7.50	21.13	15.13	27.88
20.00	1 (std.)	10.000	24.00	25.00	3.00	24	2.06	7.88	7.88	1.91	20.00	8.00	26.50	30.50	4.50	7.50	23.63	17.63	30.38

¹Optional SAE flange ports may be specified – flange to be supplied by customer. See Table 2 for flange port pattern dimensions.

²SAE straight thread ports are standard and are indicated by port number.

Table 2 – Optional SAE Flange Port Pattern

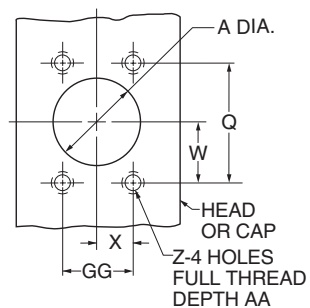

Nom. Flange Size	A	Q	GG	W	X	Z-THD UNC-2B	AA Min.	SAE
3	3.00	4.188	2.438	2.09	1.22	5/8-11	1.19	48



Head Square Flange Mounting
Style JB
(NFPA Style MF5)

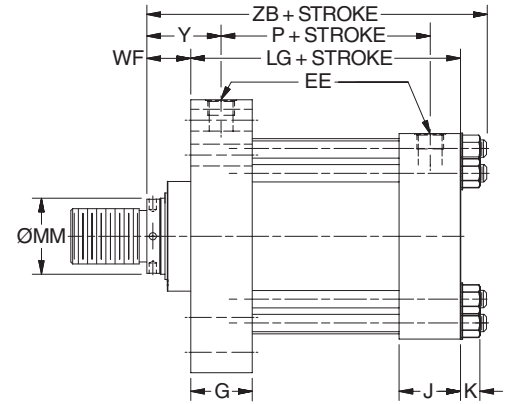
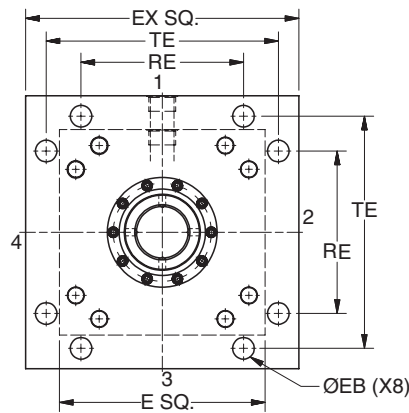
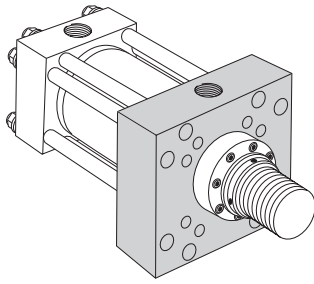

Table 1 – Dimensional and Mounting Data

Bore Ø	Rod No.	MM Rod Ø	E	EB Ø	Ports (EE)			EX	G	J	K	RE	TE	WF	Y	Add Stroke		
					NPTF ¹	SAE Flange Port ²	SAE Straight Thread Port ³									LG	P	ZB Max.
10.00	1 (std.)	4.500	12.63	1.31	2.00	2.00	24	16.63	3.69	3.69	1.28	9.89	14.13	2.94	4.75	12.13	8.50	16.69
	2	7.000	12.63	1.31	2.00	2.00	24	16.63	3.69	3.69	1.28	9.89	14.13	3.50	5.31	12.13	8.50	17.25
	3	5.000	12.63	1.31	2.00	2.00	24	16.63	3.69	3.69	1.28	9.89	14.13	3.19	5.00	12.13	8.50	16.94
	4	5.500	12.63	1.31	2.00	2.00	24	16.63	3.69	3.69	1.28	9.89	14.13	3.19	5.00	12.13	8.50	16.94
12.00	1 (std.)	5.500	14.88	1.56	2.50	2.50	24	19.75	4.44	4.44	1.41	11.75	16.79	3.19	5.38	14.50	10.13	19.44
	2	8.000	14.88	1.56	2.50	2.50	24	19.75	4.44	4.44	1.41	11.75	16.79	4.00	6.19	14.50	10.13	20.25
	3	7.000	14.88	1.56	2.50	2.50	24	19.75	4.44	4.44	1.41	11.75	16.79	3.50	5.69	14.50	10.13	19.75
14.00	1 (std.)	7.000	17.13	1.81	2.50	2.50	24	21.75	4.88	4.88	1.41	12.90	18.43	3.50	5.88	15.63	10.88	20.88
	2	10.000	17.13	1.81	2.50	2.50	24	21.75	4.88	4.88	1.41	12.90	18.43	4.50	6.88	15.63	10.88	21.88
	3	8.000	17.13	1.81	2.50	2.50	24	21.75	4.88	4.88	1.41	12.90	18.43	4.00	6.38	15.63	10.88	21.38
16.00	1 (std.)	8.000	19.00	1.81	-	3.00	24	24.50	5.88	5.88	1.91	15.28	21.03	4.00	7.00	18.13	12.13	24.38
	3	9.000	19.00	1.81	-	3.00	24	24.50	5.88	5.88	1.91	15.28	21.03	4.25	7.25	18.13	12.13	24.63
	4	10.000	19.00	1.81	-	3.00	24	24.50	5.88	5.88	1.91	15.28	21.03	4.50	7.50	18.13	12.13	24.88
18.00	1 (std.)	9.000	22.00	2.06	-	3.00	24	26.50	6.88	6.88	1.91	16.45	22.65	4.25	7.25	21.13	15.13	27.63
	3	10.000	22.00	2.06	-	3.00	24	26.50	6.88	6.88	1.91	16.45	22.65	4.50	7.50	21.13	15.13	27.88
20.00	1 (std.)	10.000	24.00	2.06	-	3.00	24	29.00	7.88	7.88	1.91	18.07	24.87	4.50	7.50	23.63	17.63	30.38

¹NPTF ports are available at no extra charge.

²Optional SAE flange ports may be specified – flange to be supplied by customer. See Table 2 for flange port pattern dimensions.

³SAE straight thread ports are standard and are indicated by port number.

Table 2 – Optional SAE Flange Port Pattern

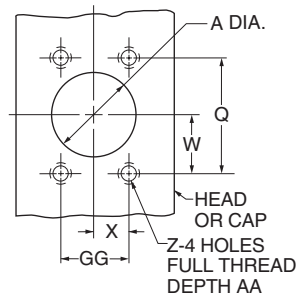

Nom. Flange Size	A	Q	GG	W	X	Z-THD UNC-2B	AA Min.	SAE
2	2.00	3.062	1.688	1.53	0.84	1/2-13	1.06	32
2 1/2	2.50	3.500	2.000	1.75	1.00	1/2-13	1.19	40
3	3.00	4.188	2.438	2.09	1.22	5/8-11	1.19	48

Cap Rectangular Mounting
Style HH
(NFPA Style ME6)

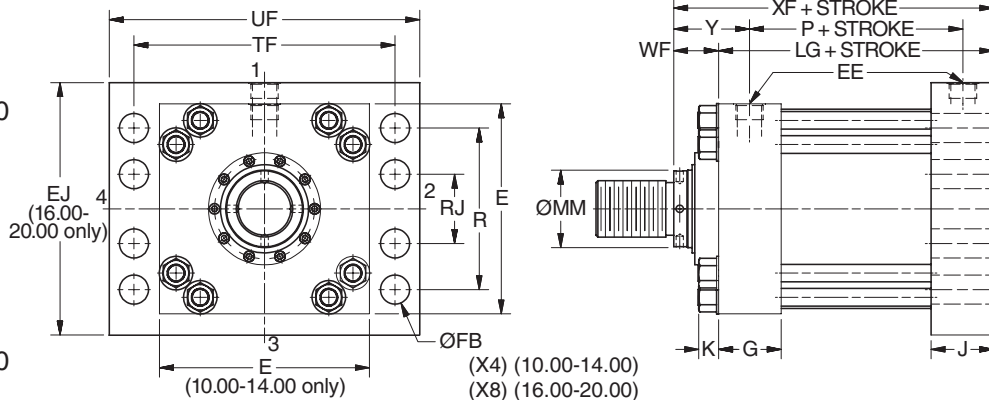
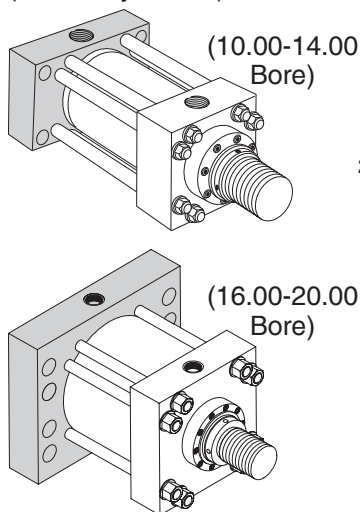

Table 1 – Dimensional and Mounting Data

Bore Ø	Rod No.	MM Rod Ø	E	Ports (EE)			EJ	FB Ø	G	J	K	R	RJ	TF	UF	WF	Y	Add Stroke		
				NPTF ¹	SAE Flange Port ²	SAE Straight Thread Port ³												LG	P	XF
10.00	1 (std.)	4.500	12.63	2.00	2.00	24	-	1.81	3.69	3.69	1.28	9.62	-	15.88	19.00	2.94	4.75	12.13	8.50	15.06
	2	7.000	12.63	2.00	2.00	24	-	1.81	3.69	3.69	1.28	9.62	-	15.88	19.00	3.50	5.31	12.13	8.50	15.63
	3	5.000	12.63	2.00	2.00	24	-	1.81	3.69	3.69	1.28	9.62	-	15.88	19.00	3.19	5.00	12.13	8.50	15.31
	4	5.500	12.63	2.00	2.00	24	-	1.81	3.69	3.69	1.28	9.62	-	15.88	19.00	3.19	5.00	12.13	8.50	15.31
12.00	1 (std.)	5.500	14.88	2.50	2.50	24	-	2.06	4.44	4.44	1.41	11.45	-	18.50	22.00	3.19	5.38	14.50	10.13	17.69
	2	8.000	14.88	2.50	2.50	24	-	2.06	4.44	4.44	1.41	11.45	-	18.50	22.00	4.00	6.19	14.50	10.13	18.50
	3	7.000	14.88	2.50	2.50	24	-	2.06	4.44	4.44	1.41	11.45	-	18.50	22.00	3.50	5.69	14.50	10.13	18.00
14.00	1 (std.)	7.000	17.13	2.50	2.50	24	-	2.31	4.88	4.88	1.41	13.26	-	21.00	25.00	3.50	5.88	15.63	10.88	19.13
	2	10.000	17.13	2.50	2.50	24	-	2.31	4.88	4.88	1.41	13.26	-	21.00	25.00	4.50	6.88	15.63	10.88	20.13
	3	8.000	17.13	2.50	2.50	24	-	2.31	4.88	4.88	1.41	13.26	-	21.00	25.00	4.00	6.38	15.63	10.88	19.63
16.00	1 (std.)	8.000	-	-	3.00	24	20.00	1.81	5.88	5.88	1.91	15.50	8.00	21.00	24.50	4.00	7.00	18.13	12.13	22.13
	3	9.000	-	-	3.00	24	20.00	1.81	5.88	5.88	1.91	15.50	8.00	21.00	24.50	4.25	7.25	18.13	12.13	22.38
	4	10.000	-	-	3.00	24	20.00	1.81	5.88	5.88	1.91	15.50	8.00	21.00	24.50	4.50	7.50	18.13	12.13	22.63
18.00	1 (std.)	9.000	-	-	3.00	24	23.00	2.06	6.88	6.88	1.91	18.00	7.25	24.25	28.25	4.25	7.25	21.13	15.13	25.38
	3	10.000	-	-	3.00	24	23.00	2.06	6.88	6.88	1.91	18.00	7.25	24.25	28.25	4.50	7.50	21.13	15.13	25.63
20.00	1 (std.)	10.000	-	-	3.00	24	25.00	2.06	7.88	7.88	1.91	20.00	8.00	26.50	30.50	4.50	7.50	23.63	17.63	28.13

¹NPTF ports are available at no extra charge.

²Optional SAE flange ports may be specified – flange to be supplied by customer. See Table 2 for flange port pattern dimensions.

³SAE straight thread ports are standard and are indicated by port number.

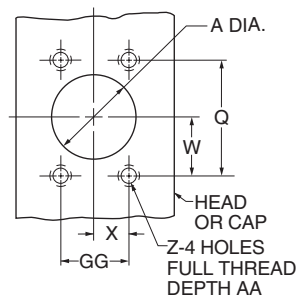

Table 2 – Optional SAE Flange Port Pattern

Nom. Flange Size	A	Q	GG	W	X	Z-THD UNC-2B	AA Min.	SAE
2	2.00	3.062	1.688	1.53	0.84	1/2-13	1.06	32
2 1/2	2.50	3.500	2.000	1.75	1.00	1/2-13	1.19	40
3	3.00	4.188	2.438	2.09	1.22	5/8-11	1.19	48



Cap Square Flange Mounting
Style HB
(NFA Style MF6)

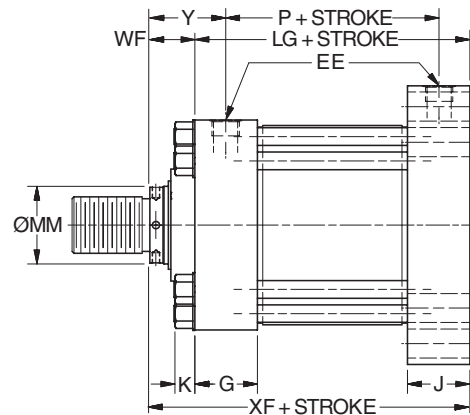
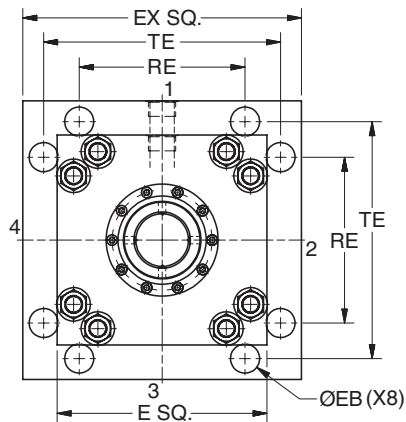
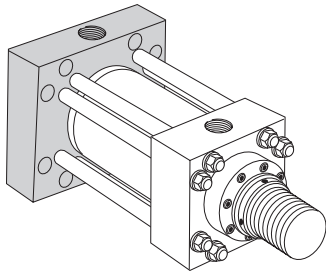

Table 1 – Dimensional and Mounting Data

Bore Ø	Rod No.	MM Rod Ø	E	EB Ø	Ports (EE)			EX	G	J	K	RE	TE	WF	Y	Add Stroke		
					NPTF ¹	SAE Flange Port ²	SAE Straight Thread Port ³									LG	P	XF
10.00	1 (std.)	4.500	12.63	1.31	2.00	2.00	24	16.63	3.69	3.69	1.28	9.89	14.13	2.94	4.75	12.13	8.50	15.06
	2	7.000	12.63	1.31	2.00	2.00	24	16.63	3.69	3.69	1.28	9.89	14.13	3.50	5.31	12.13	8.50	15.63
	3	5.000	12.63	1.31	2.00	2.00	24	16.63	3.69	3.69	1.28	9.89	14.13	3.19	5.00	12.13	8.50	15.31
	4	5.500	12.63	1.31	2.00	2.00	24	16.63	3.69	3.69	1.28	9.89	14.13	3.19	5.00	12.13	8.50	15.31
12.00	1 (std.)	5.500	14.88	1.56	2.50	2.50	24	19.75	4.44	4.44	1.41	11.75	16.79	3.19	5.38	14.50	10.13	17.69
	2	8.000	14.88	1.56	2.50	2.50	24	19.75	4.44	4.44	1.41	11.75	16.79	4.00	6.19	14.50	10.13	18.50
	3	7.000	14.88	1.56	2.50	2.50	24	19.75	4.44	4.44	1.41	11.75	16.79	3.50	5.69	14.50	10.13	18.00
14.00	1 (std.)	7.000	17.13	1.81	2.50	2.50	24	21.75	4.88	4.88	1.41	12.90	18.43	3.50	5.88	15.63	10.88	19.13
	2	10.000	17.13	1.81	2.50	2.50	24	21.75	4.88	4.88	1.41	12.90	18.43	4.50	6.88	15.63	10.88	20.13
	3	8.000	17.13	1.81	2.50	2.50	24	21.75	4.88	4.88	1.41	12.90	18.43	4.00	6.38	15.63	10.88	19.63
16.00	1 (std.)	8.000	19.00	1.81	-	3.00	24	24.50	5.88	5.88	1.91	15.28	21.03	4.00	7.00	18.13	12.13	22.13
	3	9.000	19.00	1.81	-	3.00	24	24.50	5.88	5.88	1.91	15.28	21.03	4.25	7.25	18.13	12.13	22.38
	4	10.000	19.00	1.81	-	3.00	24	24.50	5.88	5.88	1.91	15.28	21.03	4.50	7.50	18.13	12.13	22.63
18.00	1 (std.)	9.000	22.00	2.06	-	3.00	24	26.50	6.88	6.88	1.91	16.45	22.65	4.25	7.25	21.13	15.13	25.38
	3	10.000	22.00	2.06	-	3.00	24	26.50	6.88	6.88	1.91	16.45	22.65	4.50	7.50	21.13	15.13	25.63
20.00	1 (std.)	10.000	24.00	2.06	-	3.00	24	29.00	7.88	7.88	1.91	18.07	24.87	4.50	7.50	23.63	17.63	28.13

¹NPTF ports are available at no extra charge.

²Optional SAE flange ports may be specified – flange to be supplied by customer. See Table 2 for flange port pattern dimensions.

³SAE straight thread ports are standard and are indicated by port number.

Table 2 – Optional SAE Flange Port Pattern

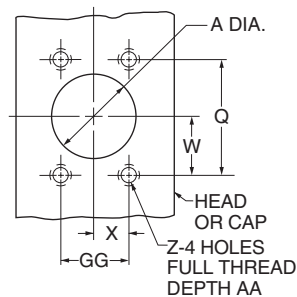

Nom. Flange Size	A	Q	GG	W	X	Z-THD UNC-2B	AA Min.	SAE
2	2.00	3.062	1.688	1.53	0.84	1/2-13	1.06	32
2 1/2	2.50	3.500	2.000	1.75	1.00	1/2-13	1.19	40
3	3.00	4.188	2.438	2.09	1.22	5/8-11	1.19	48

Side Lugs Mounting
Style C
(NFPA Style MS2)

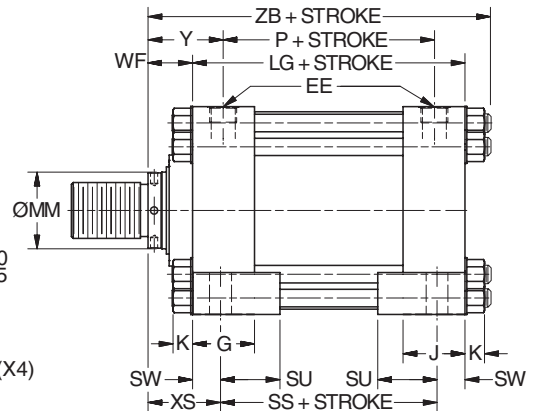
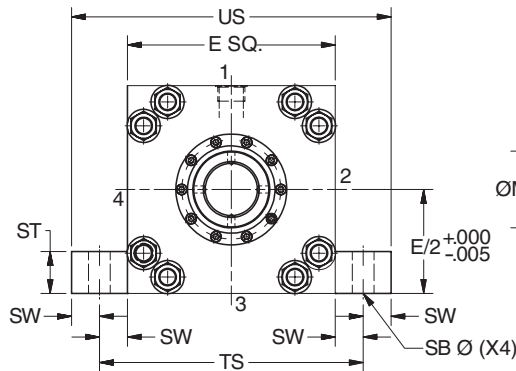
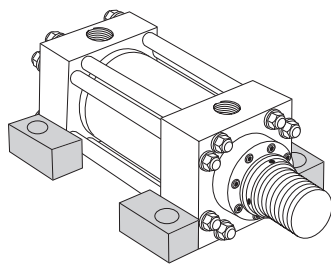

Table 1 – Dimensional and Mounting Data

Bore Ø	Rod No.	MM Rod Ø	E	Ports (EE)			G	J	K	SB Ø	ST	SU	SW	Y	TS	US	WF	XS
				NPTF ¹	SAE Flange Port ²	SAE Straight Thread Port ³												
10.00	1 (std.)	4.500	12.63	2.00	2.00	24	3.69	3.69	1.28	1.563	2.25	3.50	1.63	4.75	15.88	19.13	2.94	4.56
	2	7.000	12.63	2.00	2.00	24	3.69	3.69	1.28	1.563	2.25	3.50	1.63	5.31	15.88	19.13	3.50	5.13
	3	5.000	12.63	2.00	2.00	24	3.69	3.69	1.28	1.563	2.25	3.50	1.63	5.00	15.88	19.13	3.19	4.81
	4	5.500	12.63	2.00	2.00	24	3.69	3.69	1.28	1.563	2.25	3.50	1.63	5.00	15.88	19.13	3.19	4.81
12.00	1 (std.)	5.500	14.88	2.50	2.50	24	4.44	4.44	1.41	1.563	3.00	4.25	2.00	5.38	18.88	22.88	3.19	5.19
	2	8.000	14.88	2.50	2.50	24	4.44	4.44	1.41	1.563	3.00	4.25	2.00	6.19	18.88	22.88	4.00	6.00
	3	7.000	14.88	2.50	2.50	24	4.44	4.44	1.41	1.563	3.00	4.25	2.00	5.69	18.88	22.88	3.50	5.50
14.00	1 (std.)	7.000	17.13	2.50	2.50	24	4.88	4.88	1.41	2.313	4.00	4.75	2.25	5.88	21.63	26.13	3.50	5.75
	2	10.000	17.13	2.50	2.50	24	4.88	4.88	1.41	2.313	4.00	4.75	2.25	6.88	21.63	26.13	4.50	6.75
	3	8.000	17.13	2.50	2.50	24	4.88	4.88	1.41	2.313	4.00	4.75	2.25	6.38	21.63	26.13	4.00	6.25

¹NPTF ports are available at no extra charge.

²Optional SAE flange ports may be specified – flange to be supplied by customer. See Table 2 for flange port pattern dimensions.

³SAE straight thread ports are standard and are indicated by port number.

Table 1 – Dimensional and Mounting Data (cont.)

Bore Ø	Rod No.	MM Rod Ø	Add Stroke			
			LG	P	SS	ZB Max.
10.00	1 (std.)	4.500	12.13	8.50	8.88	16.69
	2	7.000	12.13	8.50	8.88	17.25
	3	5.000	12.13	8.50	8.88	16.94
	4	5.500	12.13	8.50	8.88	16.94
12.00	1 (std.)	5.500	14.50	10.13	10.50	19.44
	2	8.000	14.50	10.13	10.50	20.25
	3	7.000	14.50	10.13	10.50	19.75
14.00	1 (std.)	7.000	15.63	10.88	11.13	20.88
	2	10.000	15.63	10.88	11.13	21.88
	3	8.000	15.63	10.88	11.13	21.38

Table 2 – Optional SAE Flange Port Pattern

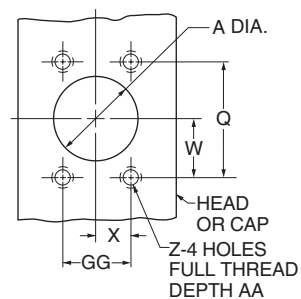

Nom. Flange Size	A	Q	GG	W	X	Z-THD UNC-2B	AA Min.	SAE
2	2.00	3.062	1.688	1.53	0.84	1/2-13	1.06	32
2 1/2	2.50	3.500	2.000	1.75	1.00	1/2-13	1.19	40



Cap Fixed Clevis Mounting
Style BB
(NFPA Style MP1)

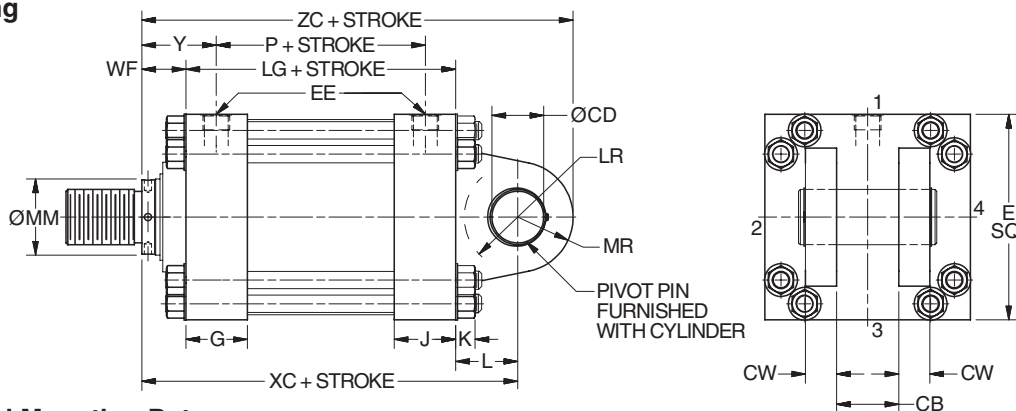
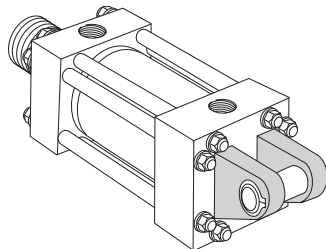

Table 1 – Dimensional and Mounting Data

Bore Ø	Rod No.	MM Rod Ø	CB	CD Ø +.001 -.003	CW	E	EE Ports			G	J	K	L	LR	MR	WF	Y	Add Stroke			
							NPTF ¹	SAE Flange Port ²	SAE Straight Thread Port ³									LG	P	XC	ZC
10.00	1 (std.)	4.500	4.00	3.500	2.00	12.63	2.00	2.00	24	3.69	3.69	1.28	4.00	3.38	3.50	2.94	4.75	12.13	8.50	19.06	22.56
	2	7.000	4.00	3.500	2.00	12.63	2.00	2.00	24	3.69	3.69	1.28	4.00	3.38	3.50	3.50	5.31	12.13	8.50	19.63	23.13
	3	5.000	4.00	3.500	2.00	12.63	2.00	2.00	24	3.69	3.69	1.28	4.00	3.38	3.50	3.19	5.00	12.13	8.50	19.31	22.81
	4	5.500	4.00	3.500	2.00	12.63	2.00	2.00	24	3.69	3.69	1.28	4.00	3.38	3.50	3.19	5.00	12.13	8.50	19.31	22.81
12.00	1 (std.)	5.500	4.50	4.000	2.25	14.88	2.50	2.50	24	4.44	4.44	1.41	4.50	3.88	4.00	3.19	5.38	14.50	10.13	22.19	26.19
	2	8.000	4.50	4.000	2.25	14.88	2.50	2.50	24	4.44	4.44	1.41	4.50	3.88	4.00	4.00	6.19	14.50	10.13	23.00	27.00
	3	7.000	4.50	4.000	2.25	14.88	2.50	2.50	24	4.44	4.44	1.41	4.50	3.88	4.00	3.50	5.69	14.50	10.13	22.50	26.50
14.00	1 (std.)	7.000	6.00	5.000	3.00	17.13	2.50	2.50	24	4.88	4.88	1.41	5.75	4.19	5.00	3.50	5.88	15.63	10.88	24.88	29.88
	2	10.000	6.00	5.000	3.00	17.13	2.50	2.50	24	4.88	4.88	1.41	5.75	4.19	5.00	4.50	6.88	15.63	10.88	25.88	30.88
	3	8.000	6.00	5.000	3.00	17.13	2.50	2.50	24	4.88	4.88	1.41	5.75	4.19	5.00	4.00	6.38	15.63	10.88	25.38	30.38
16.00	1 (std.)	8.000	7.00	6.000	3.50	19.00	-	3.00	24	5.88	5.88	1.91	7.00	6.25	6.00	4.00	7.00	18.13	12.13	29.13	35.13
	3	9.000	7.00	6.000	3.50	19.00	-	3.00	24	5.88	5.88	1.91	7.00	6.25	6.00	4.25	7.25	18.13	12.13	29.38	35.38
	4	10.000	7.00	6.000	3.50	19.00	-	3.00	24	5.88	5.88	1.91	7.00	6.25	6.00	4.50	7.50	18.13	12.13	29.63	35.63
18.00	1 (std.)	9.000	8.00	6.500	4.00	22.00	-	3.00	24	6.88	6.88	1.91	7.63	6.75	6.50	4.25	7.25	21.13	15.13	33.00	39.50
	3	10.000	8.00	6.500	4.00	22.00	-	3.00	24	6.88	6.88	1.91	7.63	6.75	6.50	4.50	7.50	21.13	15.13	33.25	39.75
20.00	1 (std.)	10.000	9.00	7.500	4.50	24.00	-	3.00	24	7.88	7.88	1.91	8.75	7.75	7.50	4.50	7.50	23.63	17.63	36.88	44.38

¹NPTF ports are available at no extra charge.

²Optional SAE flange ports may be specified – flange to be supplied by customer. See Table 2 for flange port pattern dimensions.

³SAE straight thread ports are standard and are indicated by port number.

Table 2 – Optional SAE Flange Port Pattern

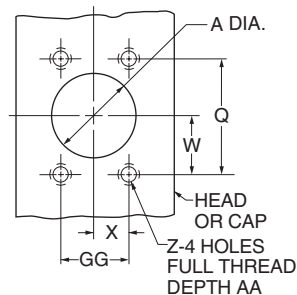

Nom. Flange Size	A	Q	GG	W	X	Z-THD UNC-2B	AA Min.	SAE
2	2.00	3.062	1.688	1.53	0.84	1/2-13	1.06	32
2 1/2	2.50	3.500	2.000	1.75	1.00	1/2-13	1.19	40
3	3.00	4.188	2.438	2.09	1.22	5/8-11	1.19	48

Head Trunnion Mounting
Style D
(NFA Style MT1)

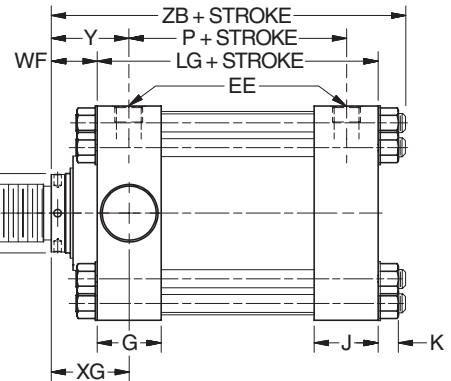
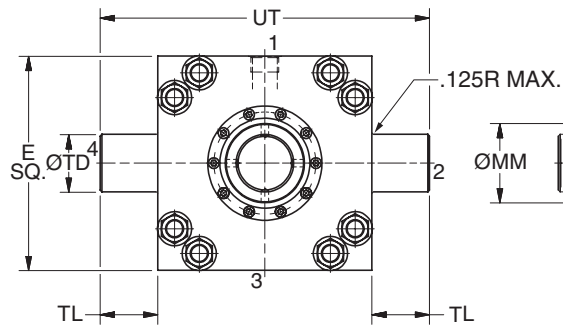
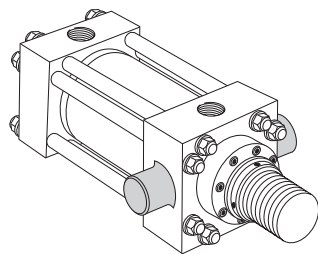

Table 1 – Dimensional and Mounting Data

Bore Ø	Rod No.	MM Rod Ø	E	Ports (EE)			G	J	K	TD Ø +.000 -.001	TL	UT	WF	XG	Y	Add Stroke		
				NPTF ¹	SAE Flange Port ²	SAE Straight Thread Port ³										LG	P	ZB Max.
10.00	1 (std.)	4.500	12.63	2.00	2.00	24	3.69	3.69	1.28	3.500	3.50	19.63	2.94	4.75	4.75	12.13	8.50	16.69
	2	7.000	12.63	2.00	2.00	24	3.69	3.69	1.28	3.500	3.50	19.63	3.50	5.31	5.31	12.13	8.50	17.25
	3	5.000	12.63	2.00	2.00	24	3.69	3.69	1.28	3.500	3.50	19.63	3.19	5.00	5.00	12.13	8.50	16.94
	4	5.500	12.63	2.00	2.00	24	3.69	3.69	1.28	3.500	3.50	19.63	3.19	5.00	5.00	12.13	8.50	16.94
12.00	1 (std.)	5.500	14.88	2.50	2.50	24	4.44	4.44	1.41	4.000	4.00	22.88	3.19	5.38	5.38	14.50	10.13	19.44
	2	8.000	14.88	2.50	2.50	24	4.44	4.44	1.41	4.000	4.00	22.88	4.00	6.19	6.19	14.50	10.13	20.25
	3	7.000	14.88	2.50	2.50	24	4.44	4.44	1.41	4.000	4.00	22.88	3.50	5.69	5.69	14.50	10.13	19.75
14.00	1 (std.)	7.000	17.13	2.50	2.50	24	4.88	4.88	1.41	4.500	4.50	26.13	3.50	5.94	5.88	15.63	10.88	20.88
	2	10.000	17.13	2.50	2.50	24	4.88	4.88	1.41	4.500	4.50	26.13	4.50	6.94	6.88	15.63	10.88	21.88
	3	8.000	17.13	2.50	2.50	24	4.88	4.88	1.41	4.500	4.50	26.13	4.00	6.44	6.38	15.63	10.88	21.38

¹NPTF ports are available at no extra charge.

²Optional SAE flange ports may be specified – flange to be supplied by customer. See Table 2 for flange port pattern dimensions.

³SAE straight thread ports are standard and are indicated by port number.

Table 2 – Optional SAE Flange Port Pattern

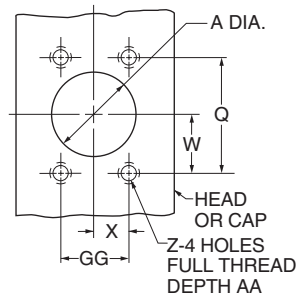

Nom. Flange Size	A	Q	GG	W	X	Z-THD UNC-2B	AA Min.	SAE
2	2.00	3.062	1.688	1.53	0.84	1/2-13	1.06	32
2 1/2	2.50	3.500	2.000	1.75	1.00	1/2-13	1.19	40

Table 3 – Maximum Operating Pressure – D Mount

Bore Ø	psi
10.00	2800
12.00	2350
14.00	2200



Cap Trunnion Mounting
Style DB
(NFPA Style MT2)

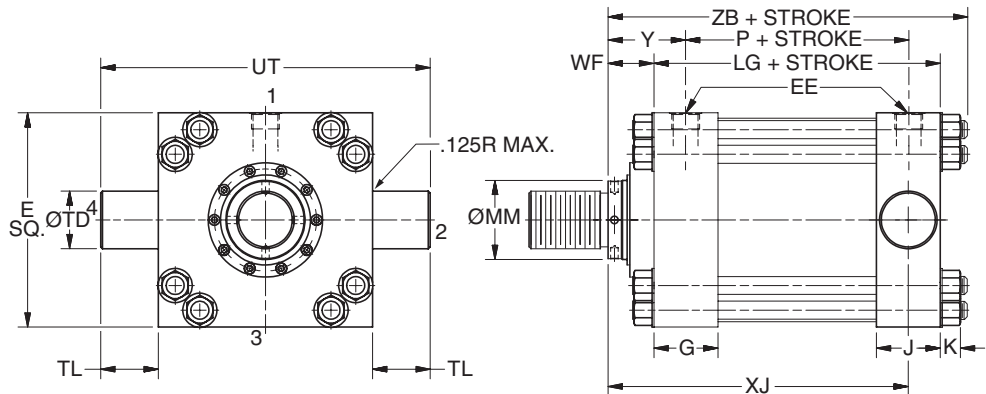
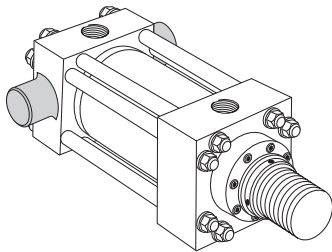

Table 1 – Dimensional and Mounting Data

Bore Ø	Rod No.	MM Rod Ø	E	Ports (EE)			G	J	K	TD Ø +.000 -.001	TL	UT	WF	Y	Add Stroke			
				NPTF ¹	SAE Flange Port ²	SAE Straight Thread Port ³									LG	P	XJ	ZB Max.
10.00	1 (std.)	4.500	12.63	2.00	2.00	24	3.69	3.69	1.28	3.500	3.50	19.63	2.94	4.75	12.13	8.50	13.38	16.69
	2	7.000	12.63	2.00	2.00	24	3.69	3.69	1.28	3.500	3.50	19.63	3.50	5.31	12.13	8.50	13.94	17.25
	3	5.000	12.63	2.00	2.00	24	3.69	3.69	1.28	3.500	3.50	19.63	3.19	5.00	12.13	8.50	13.63	16.94
	4	5.500	12.63	2.00	2.00	24	3.69	3.69	1.28	3.500	3.50	19.63	3.19	5.00	12.13	8.50	13.63	16.94
12.00	1 (std.)	5.500	14.88	2.50	2.50	24	4.44	4.44	1.41	4.000	4.00	22.88	3.19	5.38	14.50	10.13	15.50	19.44
	2	8.000	14.88	2.50	2.50	24	4.44	4.44	1.41	4.000	4.00	22.88	4.00	6.19	14.50	10.13	16.31	20.25
	3	7.000	14.88	2.50	2.50	24	4.44	4.44	1.41	4.000	4.00	22.88	3.50	5.69	14.50	10.13	15.81	19.75
14.00	1 (std.)	7.000	17.13	2.50	2.50	24	4.88	4.88	1.41	4.500	4.50	26.13	3.50	5.88	15.63	10.88	16.69	20.88
	2	10.000	17.13	2.50	2.50	24	4.88	4.88	1.41	4.500	4.50	26.13	4.50	6.88	15.63	10.88	17.69	21.88
	3	8.000	17.13	2.50	2.50	24	4.88	4.88	1.41	4.500	4.50	26.13	4.00	6.38	15.63	10.88	17.19	21.38

¹NPTF ports are available at no extra charge.

²Optional SAE flange ports may be specified – flange to be supplied by customer. See Table 2 for flange port pattern dimensions.

³SAE straight thread ports are standard and are indicated by port number.

Table 2 – Optional SAE Flange Port Pattern

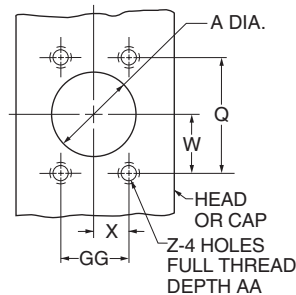

Nom. Flange Size	A	Q	GG	W	X	Z-THD UNC-2B	AA Min.	SAE
2	2.00	3.062	1.688	1.53	0.84	1/2-13	1.06	32
2 1/2	2.50	3.500	2.000	1.75	1.00	1/2-13	1.19	40

Table 3 – Maximum Operating Pressure – DB Mount

Bore Ø	psi
10.00	2800
12.00	2350
14.00	2200

Intermediate Fixed Trunnion Mounting
Style DD
(NFA Style MT4)

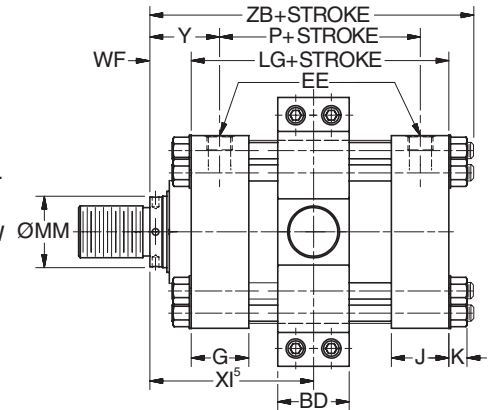
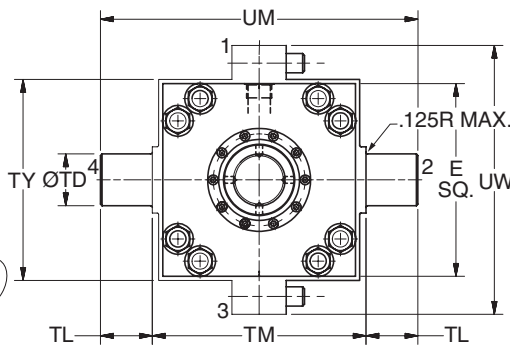
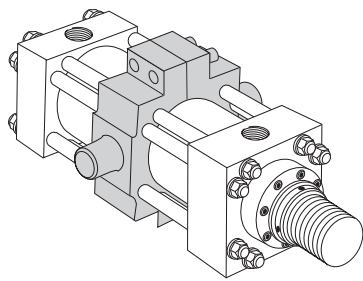

Table 1 – Dimensional and Mounting Data

Bore Ø	Rod No.	MM Rod Ø	E	EE Ports			BD	G	J	K	TD Ø +0.000 -0.001	TL	TM	TY	UM	UW	WF	Min. XI ⁵	Y	Add Stroke		
				NPTF ¹	SAE Flge. Port ²	SAE Str. Thr. Port ³														LG	P	ZB Max.
10.00	1 (std.)	4.500	12.63	2.00	2.00	24	4.50	3.69	3.69	1.28	3.500	3.50	14.00	13.00	21.00	17.50	2.94	9.06	4.75	12.13	8.50	16.69
	2	7.000	12.63	2.00	2.00	24	4.50	3.69	3.69	1.28	3.500	3.50	14.00	13.00	21.00	17.50	3.50	9.63	5.31	12.13	8.50	17.25
	3	5.000	12.63	2.00	2.00	24	4.50	3.69	3.69	1.28	3.500	3.50	14.00	13.00	21.00	17.50	3.19	9.31	5.00	12.13	8.50	16.94
	4	5.500	12.63	2.00	2.00	24	4.50	3.69	3.69	1.28	3.500	3.50	14.00	13.00	21.00	17.50	3.19	9.31	5.00	12.13	8.50	16.94
12.00	1 (std.)	5.500	14.88	2.50	2.50	24	5.50	4.44	4.44	1.41	4.000	4.00	16.50	15.50	24.50	20.75	3.19	10.63	5.38	14.50	10.13	19.44
	2	8.000	14.88	2.50	2.50	24	5.50	4.44	4.44	1.41	4.000	4.00	16.50	15.50	24.50	20.75	4.00	11.50	6.19	14.50	10.13	20.25
	3	7.000	14.88	2.50	2.50	24	5.50	4.44	4.44	1.41	4.000	4.00	16.50	15.50	24.50	20.75	3.50	10.94	5.69	14.50	10.13	19.75
14.00	1 (std.)	7.000	17.13	2.50	2.50	24	5.50	4.88	4.88	1.41	4.500	4.50	19.50	19.25	28.50	24.75	3.50	11.44	5.88	15.63	10.88	20.88
	2	10.000	17.13	2.50	2.50	24	5.50	4.88	4.88	1.41	4.500	4.50	19.50	19.25	28.50	24.75	4.50	12.44	6.88	15.63	10.88	21.88
	3	8.000	17.13	2.50	2.50	24	5.50	4.88	4.88	1.41	4.500	4.50	19.50	19.25	28.50	24.75	4.00	11.94	6.38	15.63	10.88	21.38
16.00	1 (std.)	8.000	19.00	4	3.00	24	4	5.88	5.88	1.91	4	4	4	4	4	4	4.00	4	7.00	18.13	12.13	24.38
	3	9.000	19.00	4	3.00	24	4	5.88	5.88	1.91	4	4	4	4	4	4	4.25	4	7.25	18.13	12.13	24.63
	4	10.000	19.00	4	3.00	24	4	5.88	5.88	1.91	4	4	4	4	4	4	4.50	4	7.50	18.13	12.13	24.88
18.00	1 (std.)	9.000	22.00	4	3.00	24	4	6.88	6.88	1.91	4	4	4	4	4	4	4.25	4	7.25	21.13	15.13	27.63
	3	10.000	22.00	4	3.00	24	4	6.88	6.88	1.91	4	4	4	4	4	4	4.50	4	7.50	21.13	15.13	27.88
20.00	1 (std.)	10.000	24.00	4	3.00	24	4	7.88	7.88	1.91	4	4	4	4	4	4	4.50	4	7.50	23.63	17.63	30.38

¹NPTF ports are available at no extra charge.

²Optional SAE flange ports may be specified – flange to be supplied by customer. See Table 2 for flange port pattern dimensions.

³SAE straight thread ports are standard and are indicated by port number.

⁴Consult Factory

⁵Dimension XI to be specified by customer.

Table 2 – Optional SAE Flange Port Pattern

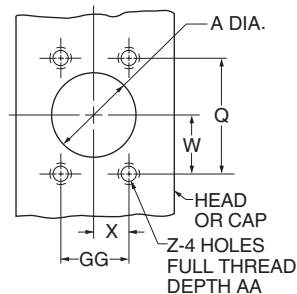

Nom. Flange Size	A	Q	GG	W	X	Z-THD UNC-2B	AA Min.	SAE
2	2.00	3.062	1.688	1.53	0.84	1/2-13	1.06	32
2 1/2	2.50	3.500	2.000	1.75	1.00	1/2-13	1.19	40
3	3.00	4.188	2.438	2.09	1.22	5/8-11	1.19	48

Table 3 – Maximum Operating Pressure – DD Mount

Bore Ø	psi
10.00	2800
12.00	2350
14.00	2200



**Double Rod Cylinder
Style K**

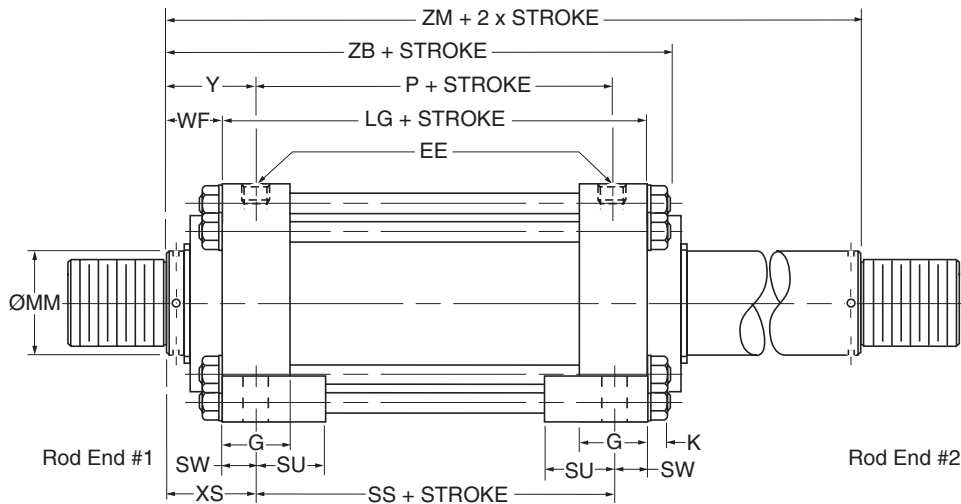

Mounting Styles for Single Rod Models	Mounting Styles for Corresponding Double Rod Models ¹	Dimension Shown on This Page Supplement Dimensions on Pages Listed Below
TB	KTB	53
TD	KTD	53
JJ	KJJ	54/55
JB	KJB	56
C	KC	59
D	KD	61
DD ²	KDD	63

¹If only one end of these Double Rod Cylinders is to be cushioned, be sure to specify clearly which end this will be.

²Specify XI dimension from rod end #1.

Bore Ø	Rod Code	Rod Ø	Add 2X Stroke
			ZM
10.00	1	4.500	18.00
	2	7.000	19.12
	3	5.000	18.50
	4	5.500	18.50
12.00	1	5.500	20.88
	2	8.000	22.50
	3	7.000	21.50
14.00	1	7.000	22.63
	2	10.000	24.63
	3	8.000	23.63
16.00	1	8.000	26.13
	3	9.000	26.63
	4	10.000	27.13
18.00	1	9.000	29.63
	3	10.000	30.13
20.00	1	10.000	32.63

**How to Use Double Rod Cylinder
Dimension Drawings**

To obtain dimensioning information on a double rod cylinder, first select the desired mounting style and refer to the corresponding single rod cylinder model shown on the preceding pages. (See table above.) After you have determined all necessary dimensions from that drawing, turn back to this page and supplement those dimensions with additional ones from the drawing above and table at right. These added dimensions differ from, or are in addition to, those shown on the preceding pages and provide the

additional information needed to completely dimension a double rod cylinder model.

On a double rod cylinder where the two rod ends are different, be sure to clearly state which rod end is to be assembled at which end. Port position 1 is standard. If other than standard, specify pos. 2, 3 or 4 when viewed from rod end #1 only. See port position information in Section E.