



BUILT TO LAST



TABLE OF CONTENTS

Warranty	3
Basic System Set Ups	4
Cylinders	5-26
Single Acting Cylinders	5
Double Acting Cylinders	8
Lock Nut Cylinders	10
Low Profile Lock Nut Cylinders	12
Aluminum Cylinders	13
Hollow Hole Cylinders	14
Double Acting Hollow Hole Cylinders	15
Flat Body Cylinders	16
Flat Body Cylinder Kits	17
Low Profile Cylinders	18
Low Profile Cylinder Kits	19
Load Cells	19
High Tonnage Single Acting Cylinders	20
High Tonnage Double Acting Cylinders (HDG Series)	22
High Tonnage Double Acting Cylinders (HD Series)	24
Pull Cylinders	25
Threaded Cylinders	25
Precision Double Acting Cylinders	26
Cylinder Accessories	27
Cylinder Lifting Handles	27
Clevis and Tangs	27
Bases	28
Saddles	28
Pump / Cylinder Combo	29
Pumps	30
Metal Air Pumps	31
Double Acting Air Pump	32
Remote Control Air Pumps	32
Rotary Air Pumps	33
All Position Air Pumps	34
Single Speed Metal Hand Pumps	35
Low Pressure Hand Pumps	36
Two Speed Aluminum Hand Pumps All Direction Hand Pump	36
Two Speed Aluminum Hand Pumps	37

Two Speed Metal Hand Pumps	38
Double Acting Hand Pump	39
Electric Pumps	40
Electric Pumps with Locking Manual Valve	42
Electric Pumps with Pendant Switch	44
Electric Pumps with Locking Manual Valve and Pendant Switch	46
Electric Pumps with Locking Solenoid Valve	48
Electric Pump with Auto Return Valve	50
3 Phase Electric Motor Pumps	52
Gas Pump with Honda Engines	52
Gas Pump with Solenoid Valve and Honda Engines	53
Diesel Pump with Solenoid Valve and Hatz Engines	54
Maintenance Kits	55
Flange Spreaders	55
Spreaders	55
Shop Presses & Accessories	56
Jacks	60
Manual Bottle Jacks	60
Air / Manual Bottle Jacks	60
Toe Jacks	60
Mini Jacks	61
Bead Breaker	61
Accessories	62
Flow Control Valves	62
Manifolds	63
Pressure Gauges	64
Gauge Adapter	64
Hydraulic Oil	64
Solenoid Valve	64
Pump Mounted Manifold Block	65
Plastic Dust Cover	65
Foot Pedal	65
Hydraulic Couplers	66
Hydraulic Hoses and Hose Sets	66
Pump Mounted Valves	67
Remote Mounted Directional Control Valves	68
Fittings	69
BVA Cross Reference Chart	70
Safety Instructions	71

MODEL NUMBER INDEX

AP	A 59	CVP 62	HT 25, 28, 70	J22 61	PESML 48
		CVR 62	HTD 28	J50 55	PEW 44
	C 69	CVS 65	HU 13, 70	J72 19	PEWL 46
CA		F	I	L	PEWM 44
CB	28, 69	F 64	IAP 56	LC 19	PEWML 46
CDC	65	FCMH 63	IAPD 56	LCH 19	PG 52
CEB	27	FT 69	IAPDR 58	LH 27	PGSL 53
CED	27	G	IAPR 58	M	PGSML 53
CEP	27	GD 64	IEP 56	MFC 63	PR 68
CF	64	GW 64	IEPD 56	P	PS 64
CFS	66	H	IEPDR 58	P 29,35-39,71	PW 67
CH	66	H 5-7,27-29,70	IEPDRS 58	PA 29,31-32,71	S
CM	63	HC 14,27,29, 70	IEPDS 56	PAR 33,71	SA 29
CMH	63	HD 8-9,24,27-28, 70	IEPR 58	PARD 33,71	SAL 29
CMR	65	HDC 15,27	IEPRS 58	PARM 33	SD 28
CP	27	HDG 22,28	IEPS 56	PDSL 54	SDT 28
CR	66	HF 16-17, 29, 70	IMP 56	PDSML 54	SDTG 28
CRZ	66	HFS 55	IMPD 56	PE 40	SP 29
CS	29, 59, 66	HG 20,28	IMPR 58	PED 50	SR 55
CT	66	HL 18, 29, 70	J	PEDS 50	
CVC	62	HLN 10, 27-28, 70	J10 60	PEL 42	
CVM	62	HLNF 12	J11 61	PELM 42	
CVMS	62	HP 25,27, 70	J13 60	PEM 40	
CVN	62	HPD 26	J18 60	PESL 48	

CONFIDENCE BUILT ON QUALITY

• ISO 9001

BVA products are manufactured through an International Quality Assurance System, ISO 9001 which involves consistent observation of administration, management, manufacturing, and production control. Under this system, the related operations are monitored on all aspects of the production of BVA products from the purchase order, the assembly line, to shipping the order from the distribution center.

BVA Products comply with the following industry standards

• ASME B30.1

The cylinders comply with load testing requirements and / or the safety factor for material yield strength, while still functioning properly and without oil leakage. (Except HPD and HLN series)

• ANSI B40.1

Under ANSI standards, BVA pressure gauges meet criteria for grade A

• SAE 100

BVA hydraulic hoses comply with the Material Handling Institute's specification of minimum life cycles and minimum burst pressure rating.

BVA Lifetime Warranty

BVA products are warranted to be free of defects in materials and workmanship. Any BVA product that does not conform to specification will be repaired or credited (at BVA's option) at BVA's expense for the life of the product. Simply contact BVA for disposition of this warranty.

This warranty does not cover ordinary wear and tear, abuse, misuse, alteration, or use of improper fluids or maintenance as determined by BVA and its authorized service dealers. All electric motors, gas engines, batteries and other parts or materials sold with or part of BVA products but that are separately warranted by another manufacturer are covered by that manufacturer's warranty and not the BVA Lifetime Warranty. BVA shall not be liable for consequential or incidental damage or loss whatsoever.

Repair parts available

CYLINDER MODEL NUMBER MATRIX

HDC3006T*

H DC 30 06 T

Letter Postscript

- T - BVA factory designation
- B - Flat body cylinder kits with magnetic base mounted adaptors
- XT - No internal ram threads, HC models only

Cylinder Stroke

- 00 - .63" stroke
- 01 - 1" stroke
- 04 - 4" stroke
- 06 - 6" stroke
- 10 - 10" stroke, etc.
- HF & HL cylinder stroke lengths vary by capacity
- Stroke lengths are approximate

Cylinder Capacity

02 - 2, 2½ tons	15 - 15 tons	50 - 50 tons	150 - 150 tons
04 - 4 tons	16 - 16 tons	60 - 60 tons	200 - 200 tons
05 - 5 tons	20 - 20 tons	75 - 75 tons	300 - 300 tons
09 - 9 tons	25 - 25 tons	25 - 25 tons	
10 - 10 tons	30 - 30 tons	100 - 100 tons	

Cylinder Options

C - Hollow hole cylinder	L - Low profile cylinders
D - Double acting cylinder	LN - Lock nut cylinder
DC - Double acting hollow hole cylinder	LNF - Low profile lock nut cylinders
F - Flat body cylinders	P - Pull cylinders
G - High tonnage cylinders	PD - Precision double acting cylinders
DG - Double acting high tonnage	T - Threaded cylinders
U - Aluminum cylinders	

Hydraulic Cylinders

* Not all combinations of tonnage and stroke are available. Please refer to the appropriate section of this catalog for available options or call (888) 332-6419

Single Push Application

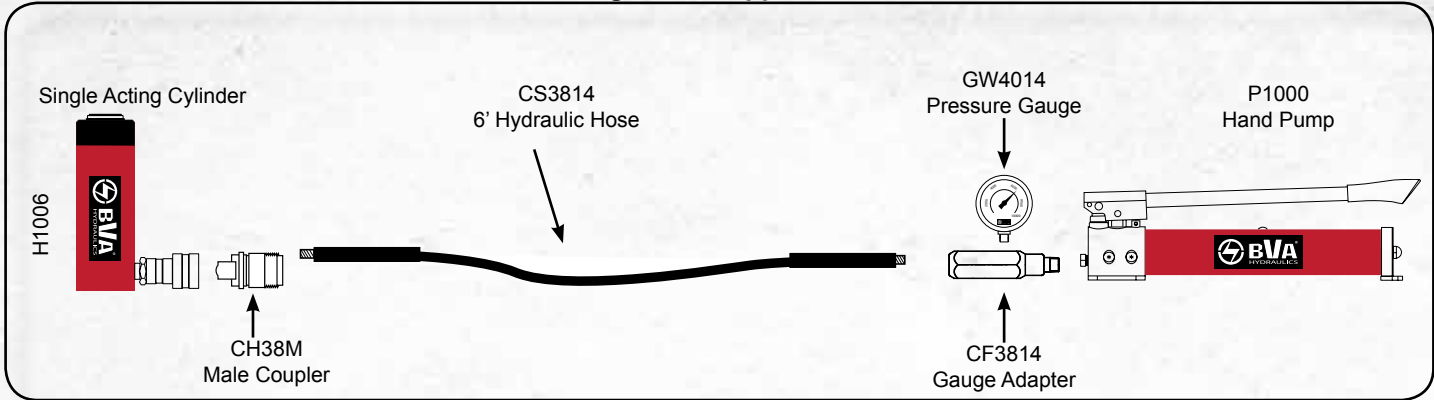

Single Acting Cylinder with longer strokes

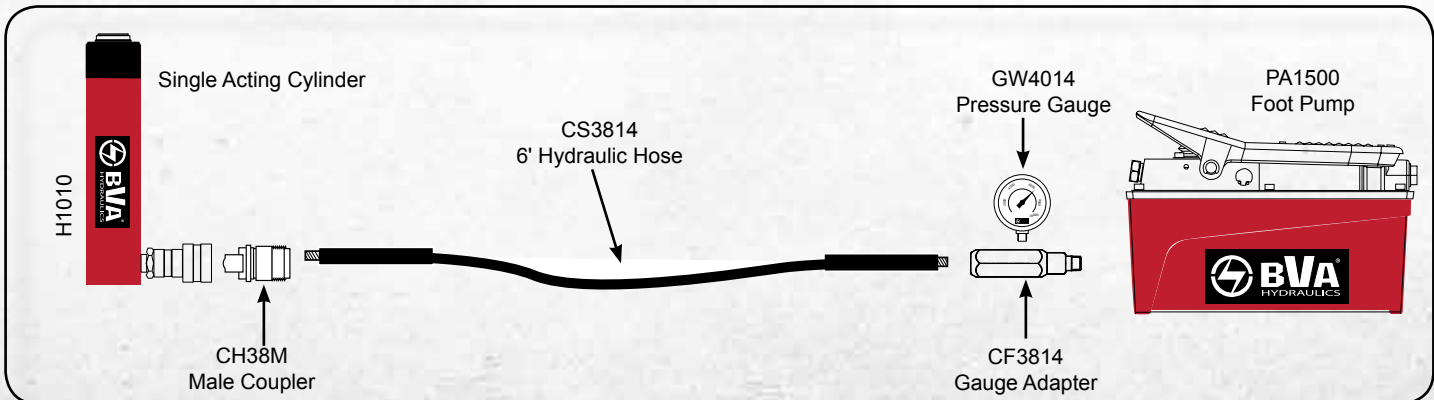

Double Acting Cylinder Set-up

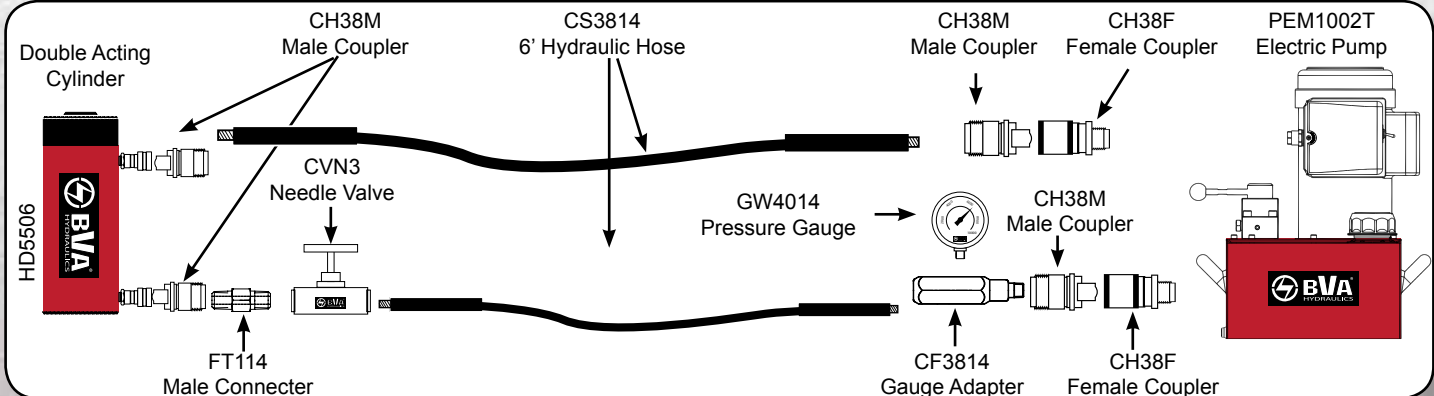

SINGLE ACTING CYLINDERS

- 42 Models
- Rod wiper seals out dirt and contamination
- Collar fixture threads and thread protection cover
- Two base mounting holes on most models
- High strength steel construction from gun drilled solid bar
- One piece high grade alloy bearing for side load protection and long life
- Polyurethane cup seal provides for optimum performance
- Industrial hard chrome plated rod helps prevent rust and corrosion
- Solid steel cylinder body
- Heavy duty return spring provides quicker retraction
- Ideal for lifting and pressing
- Maximum working pressure: 10,000 psi / 700 bar
- H5506, H5513, and all 75 and 100 ton cylinders are equipped with carrying handles



**High-Flow Coupler: CH38F
Included on all models**

*H0203 comes with CRZ14F

THE BVA ADVANTAGE

Heavy duty, heat treated, grooved saddle provides better surface traction during operation

Rod wiper seals out dirt and contamination

Industrial hard chrome plated rod prevents scratching and corrosion

One piece steel rod stopper for extra strength and prevents over travel

Polyurethane cup seal provides optimum performance

Rectangular return spring design results in even distribution of the load, eliminating spring breakage and creating quicker retraction

Steel stop ring for rod over travel protection

Collar fixture threads

Cylinders are burnish rolled for a smooth precision mirror finish, which reduces scoring and prolongs seal life

One piece high grade alloy bearing for side load protection and long life

High flow ball coupler provides more flow than conventional couplers

- **BVA Lifetime Warranty • Repair Parts Available**
- **All Cylinders Are Tested to Exceed Industrial Standards**

SINGLE ACTING CYLINDERS

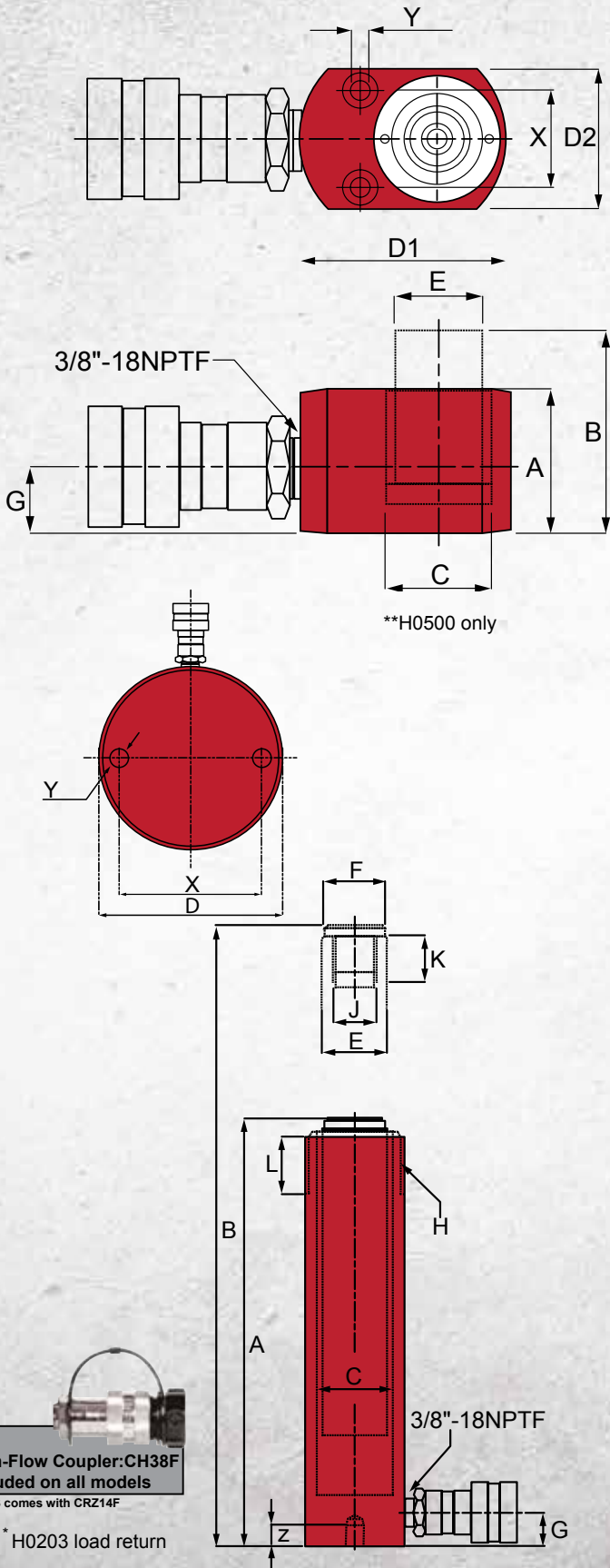

Cylinder Capacity (tons)	Stroke (in)	Model Number	Cylinder Effective Area (in ²)	Internal Pressure at Capacity (psi)	Oil Capacity (in ³)	Weight (Lbs)
2	3.07	H0203*	0.76	5,263	2.28	2
	0.63	H0500**	1.1	9,091	0.69	1.85
5	1	H0501	1.0	10,000	1	3.1
	3.07	H0503	1.0	10,000	3.07	3.17
	5.08	H0505	1.0	10,000	5.08	3.93
	7.09	H0507	1.0	10,000	7.09	4.7
	9	H0509	1.0	10,000	9.03	5.5
10	0.98	H1001	2.24	8,928	2.19	3.92
	2.01	H1002	2.24	8,928	4.5	4.96
	4.02	H1004	2.24	8,928	9.0	7.67
	5.94	H1006	2.24	8,928	13.3	9.45
	7.95	H1008	2.24	8,928	17.81	11.33
	9.96	H1010	2.24	8,928	22.31	13.07
	11.97	H1012	2.24	8,928	26.81	15.04
	14.02	H1014	2.24	8,928	31.4	16.65
15	0.98	H1501	3.14	9,554	3.07	6.9
	2.01	H1502	3.14	9,554	6.31	8.53
	3.98	H1504	3.14	9,554	12.49	11.13
	5.98	H1506	3.14	9,554	18.77	14.83
	7.99	H1508	3.14	9,554	25.08	17.33
	10	H1510	3.14	9,554	31.4	19.97
	12.01	H1512	3.14	9,554	37.71	22.54
25	1.02	H2501	5.15	9,708	5.25	12.06
	2.01	H2502	5.15	9,708	10.35	14
	4.02	H2504	5.15	9,708	20.7	18.03
	6.1	H2506	5.15	9,708	31.41	22.23
	8.11	H2508	5.15	9,708	41.77	26.27
	10.12	H2510	5.15	9,708	52.12	30.3
	12.2	H2512	5.15	9,708	62.83	34.27
30	14.25	H2514	5.15	9,708	73.39	38.3
	8.27	H3008	6.49	9,245	53.67	40.72
55	2.01	H5502	10.98	10,018	21.97	33
	4.06	H5504	10.98	10,018	44.57	41
	6.26	H5506 ±	10.98	10,018	68.73	57.5
	10.25	H5510	10.98	10,018	112.55	67.4
	13.27	H5513 ±	10.98	10,018	145.7	87
75	6.14	H7506 ±	16.1	9,316	98.85	74
	13.11	H7513 ±	16.1	9,316	211.07	122
100	2.01	H10002A ±	20.58	9,718	41.34	66
	6.61	H10006 ±	20.58	9,718	136.03	127
	10.24	H10010 ±	20.58	9,718	210.74	153

Model Number	Collapsed Height A (in)	Extended Height B (in)	Cylinder Bore C (in)	Outside Diameter D (in)	Rod Diameter E (in)	Saddle Diameter F (in)	Base to Inlet Port G (in)	Collar Thread H (in)	Collar Thread Length L (in)	Rod Internal Thread J (in)	Rod Thread Length K (in)	Base Mounting Hole		
												Bolt Circle X (in)	Thread Y (in)	Thread Depth Z (in)
H0203*	5.39	8.46	1	1.31	0.87	1	0.46	1¼"-16	0.54	-	-	-	-	-
H0500**	1.63	2.26	1.18	L2.37xW1.59xH1.63	0.98	-	0.75	-	-	-	-	1.1	-	-
H0501	4.58	5.58	1.13	1.50	1.0	0.98	0.79	1½"-16	1.1	¾"-16UNF	0.63	1.0	¼"-20UNC	0.55
H0503	6.65	9.72	1.13	1.50	1.0	0.98	0.79	1½"-16	1.1	¾"-16UNF	0.63	1.0	¼"-20UNC	0.55
H0505	8.7	13.78	1.13	1.50	1.0	0.98	0.79	1½"-16	1.1	¾"-16UNF	0.63	1.0	¼"-20UNC	0.55
H0507	10.71	17.8	1.13	1.50	1.0	0.98	0.79	1½"-16	1.1	¾"-16UNF	0.63	1.0	¼"-20UNC	0.55
H0509	12.75	21.75	1.12	1.5	1.0	0.98	0.79	1½"-16	1.1	¾"-16UNF	0.63	1.0	¼"-20UNC	0.55
H1001	3.62	4.6	1.69	2.26	1.49	-	0.77	2¼"-14	1.18	10-24UNC	0.24	1.56	5/16"-18UNC	0.55
H1002	4.84	6.85	1.69	2.26	1.49	1.38	0.77	2¼"-14	1.18	1"-8UNC	0.79	1.56	5/16"-18UNC	0.55
H1004	6.85	10.87	1.69	2.26	1.49	1.38	0.77	2¼"-14	1.18	1"-8UNC	0.79	1.56	5/16"-18UNC	0.55
H1006	9.84	15.78	1.69	2.26	1.49	1.38	0.77	2¼"-14	1.18	1"-8UNC	0.79	1.56	5/16"-18UNC	0.55
H1008	11.85	19.8	1.69	2.26	1.49	1.38	0.77	2¼"-14	1.18	1"-8UNC	0.79	1.56	5/16"-18UNC	0.55
H1010	13.86	23.82	1.69	2.26	1.49	1.38	0.77	2¼"-14	1.18	1"-8UNC	0.79	1.56	5/16"-18UNC	0.55
H1012	15.87	27.84	1.69	2.26	1.49	1.38	0.77	2¼"-14	1.18	1"-8UNC	0.79	1.56	5/16"-18UNC	0.55
H1014	17.72	31.74	1.69	2.26	1.49	1.38	0.77	2¼"-14	1.18	1"-8UNC	0.79	1.56	5/16"-18UNC	0.55
H1501	4.88	5.86	2.0	2.75	1.63	1.5	0.77	2¼"-16	1.18	1"-8UNC	0.98	1.88	¾"-16UNC	0.51
H1502	5.87	7.88	2.0	2.75	1.63	1.5	0.77	2¼"-16	1.18	1"-8UNC	0.98	1.88	¾"-16UNC	0.51
H1504	7.87	11.85	2.0	2.75	1.63	1.5	0.77	2¼"-16	1.18	1"-8UNC	0.98	1.88	¾"-16UNC	0.51
H1506	10.63	16.61	2.0	2.75	1.63	1.5	0.98	2¼"-16	1.18	1"-8UNC	0.98	1.88	¾"-16UNC	0.51
H1508	12.64	20.63	2.0	2.75	1.63	1.5	0.98	2¼"-16	1.18	1"-8UNC	0.98	1.88	¾"-16UNC	0.51
H1510	14.65	24.65	2.0	2.75	1.63	1.5	0.98	2¼"-16	1.18	1"-8UNC	0.98	1.88	¾"-16UNC	0.51
H1512	16.65	28.66	2.0	2.75	1.63	1.5	0.98	2¼"-16	1.18	1"-8UNC	0.98	1.88	¾"-16UNC	0.51
H1514	18.66	32.68	2.0	2.75	1.63	1.5	0.98	2¼"-16	1.18	1"-8UNC	0.98	1.88	¾"-16UNC	0.51
H2501	5.63	6.65	2.56	3.35	2.24	1.97	0.98	3-5/16"-12	1.93	1½"-16	1.18	2.31	½"-13UNC	0.75
H2502	6.61	8.62	2.56	3.35	2.24	1.97	0.98	3-5/16"-12	1.93	1½"-16	1.18	2.31	½"-13UNC	0.75
H2504	8.62	12.64	2.56	3.35	2.24	1.97	0.98	3-5/16"-12	1.93	1½"-16	1.18	2.31	½"-13UNC	0.75
H2506	10.71	16.81	2.56	3.35	2.24	1.97	0.98	3-5/16"-12	1.93	1½"-16	1.18	2.31	½"-13UNC	0.75
H2508	12.72	20.83	2.56	3.35	2.24	1.97	0.98	3-5/16"-12	1.93	1½"-16	1.18	2.31	½"-13UNC	0.75
H2510	14.72	24.84	2.56	3.35	2.24	1.97	0.98	3-5/16"-12	1.93	1½"-16	1.18	2.31	½"-13UNC	0.75
H2512	16.77	28.97	2.56	3.35	2.24	1.97	0.98	3-5/16"-12	1.93	1½"-16	1.18	2.31	½"-13UNC	0.75
H2514	18.74	32.99	2.56	3.35	2.24	1.97	0.98	3-5/16"-12	1.93	1½"-16	1.18	2.31	½"-13UNC	0.75
H3008	15.24	23.51	2.87	4.0	2.24	1.97	1.97	3-5/16"-12	1.93	1½"-16	1.18	2.2	-	-
H5502	6.93	8.94	3.74	5.0	3.15	2.76	1.22	5"-12	2.17	-	-	3.75	½"-13UNC	0.75
H5504	8.94	13	3.74	5.0	3.15	2.76	1.22	5"-12	2.17	-	-	3.75	½"-13UNC	0.75
H5506	11.14	17.4	3.74	5.0	3.15	2.76	1.22	5"-12	2.17	-	-	3.75	½"-13UNC	0.75
H5510	15.16	25.41	3.74	5.0	3.15	2.76	1.22	5"-12	2.17	-	-	3.75	½"-13UNC	0.75
H5513	18.15	31.42	3.74	5.0	3.15	2.76	1.22	5"-12	2.17	-	-	3.75	½"-13UNC	0.75
H7506	11.22	17.36	4.53	5.79	3.74	2.76	1.18	5¾"-12	1.77	-	-	-	-	-
H7513	19.37	32.48	4.53	5.79	3.74	2.76	1.18	5¾"-12	1.77	-	-	3.94	21/32"-10UNC	0.85
H10002A	8.62	10.63	5.12	6.25	4.13	2.76	1.5	6¼"-12	2.17	-	-	-	-	-
H10006	14.06	20.67	5.12	6.97	4.13	2.76	1.57	6¾"-12	1.77	-	-	5.5	3/4"-10UNC	1
H10010	17.68	27.92	5.12	6.97	4.13	2.76	1.57	6¾"-12	1.77	-	-	5.5	3/4"-10UNC	1

DOUBLE ACTING CYLINDERS

- Rod wiper seals out dirt and contamination
- High strength steel construction from gun drilled solid bar
- High flow 3/8" NPTF couplers
- One piece high grade alloy bearing for side load protection and long life
- Ideal for pushing and pulling
- Maximum working pressure: 10,000 psi / 700 bar
- Retract under hydraulic power for faster operation
- 55-100 Tons models are equipped with carrying handles



HD cylinders can be used in pushing and pulling applications



High-Flow Coupler:CH38F
Included on all models

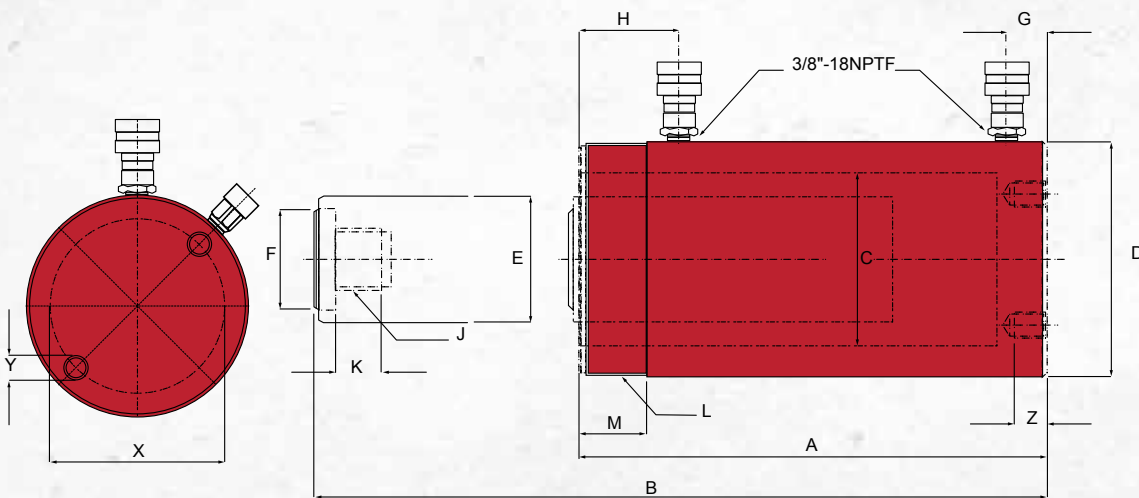

Cylinder Capacity (tons)	Stroke (in)	Model Number	Maximum Cylinder Capacity		Cylinder Effective Area		Oil Capacity		Weight (lbs)	Collapsed Height A (in)	Extended Height B (in)	Cylinder Bore Dia. C (in)
			Push (ton)	Pull (ton)	Push (in ²)	Pull (in ²)	Push (in ²)	Pull (in ²)				
10	10.04	HD1010	11.40	3.80	2.24	0.74	22.41	7.47	26.7	16.12	26.19	1.69
	11.97	HD1012	11.40	3.80	2.24	0.74	26.71	8.90	30.0	18.03	30.00	1.69
25	5.90	HD2506	25.7	13.39	5.14	2.68	30.35	15.81	24.8	10.56	16.46	2.56
30	8.15	HD3008	32.90	16.20	6.49	3.19	52.93	26.02	43.0	15.31	23.46	2.87
	14.49	HD3014	32.90	16.20	6.49	3.19	94.09	46.26	60.6	21.65	36.14	2.87
55	6.18	HD5506 ±	55.70	16.20	10.99	3.19	67.93	19.74	70.5	13.03	19.21	3.74
	13.19	HD5513 ±	55.70	16.20	10.99	3.19	144.94	42.11	104.0	20.04	33.23	3.74
	20.12	HD5520 ±	55.70	16.20	10.99	3.19	221.09	64.24	146.2	28.86	49.98	3.74
75	6.10	HD7506 ±	81.70	25.90	16.09	5.12	98.10	31.21	93.7	13.70	19.80	4.53
	13.11	HD7513 ±	81.70	25.90	16.09	5.12	210.93	67.06	136.8	20.71	33.82	4.53
100	6.57	HD10006 ±	104.40	48.60	20.57	9.58	135.23	62.98	138.6	14.06	20.63	5.12
	10.13	HD10010 ±	104.4	48.6	20.57	9.58	208.3	97.1	169.2	17.67	27.80	5.12
	13.11	HD10013 ±	104.40	48.60	20.57	9.58	269.66	125.58	193.6	20.63	33.74	5.12
	18.15	HD10018 ±	104.40	48.60	20.57	9.58	373.31	173.86	248.3	27.05	45.20	5.12

± Cylinder is equipped with carrying handle

Model Number	Outside Dia. D (in)	Rod Dia. E (in)	Saddle Dia. F (in)	Base to Adv. Port G (in)	Top to Return Port H (in)	Rod Internal Thread J (in)	Rod Thread Length K (in)	Collar Thread L (in)	Collar Thread Length M (in)	Base Mounting Hole		
										Bolt Circle X (in)	Thread Y (in)	Thread Depth Z (in)
HD1010	2.87	1.38	1.38	1.42	2.09	1"-8	0.98	2¼"-14	1.02	1.3	5/16"-18	0.6
HD1012	2.87	1.37	1.38	1.42	2.09	1"-8	0.98	2¼"-14	1.02	1.3	5/16"-18	0.6
HD2506	3.62	1.77	1.50	0.98	1.93	1"-8	1.18	3-5/16"-12	0.98	2.3	½"-13	0.7
HD3008	3.98	2.13	1.97	1.65	2.91	1½"-16	0.98	3-5/16"-12	1.93	2.2	½"-13	0.7
HD3014	3.98	2.13	1.97	1.65	2.91	1½"-16	0.98	3-5/16"-12	1.93	2.2	½"-13	0.7
HD5506	5.00	3.14	2.76	1.14	2.87	1"-12	0.98	5"-12	1.73	3.7	½"-13	0.7
HD5513	5.00	3.14	2.76	1.14	2.87	1"-12	0.98	5"-12	1.73	3.7	½"-13	0.7
HD5520	5.00	3.14	2.76	1.14	2.87	1"-12	0.98	5"-12	1.73	3.7	½"-13	0.7
HD7506	5.75	3.75	2.76	1.18	2.80	1"-12	1.50	5¾"-12	1.50	4	¾"-10	0.9
HD7513	5.75	3.75	2.76	1.18	2.80	1"-12	1.50	5¾"-12	1.50	4	¾"-10	0.9
HD10006	6.97	3.75	2.95	1.22	2.95	1¼"-12	1.38	6⅝"-12	1.97	5.47	¾"-10	0.98
HD10010	6.97	3.74	2.95	1.22	2.95	1¼"-12	1.50	6⅝"-12	2.01	5.5	¾"-10	0.98
HD10013	6.97	3.75	2.95	1.22	2.95	1¼"-12	1.38	6⅝"-12	1.97	5.47	¾"-10	0.98
HD10018	6.97	3.75	2.95	1.50	2.95	1¼"-12	1.38	6⅝"-12	1.97	5.47	¾"-10	0.98

LOCK NUT CYLINDERS

- Single acting cylinder with mechanical safety lock nut
- Designed to support load for extended periods without hydraulic pressure
- Overflow port prevents cylinders from over travel
- Load return
- Solid steel cylinder body
- Ideal for lifting and holding loads
- Chrome rods to resist corrosion and rust
- Maximum working pressure: 10,000 psi / 700 bar



(42) HLN5508 cylinders lifting the Jordan Bridge in Cheasapeake, VA.



Lock Nut Cylinders lifting a bridge in Chandler, AZ

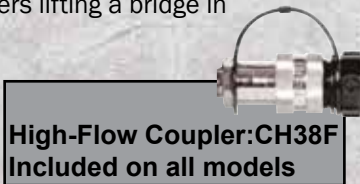

**High-Flow Coupler: CH38F
Included on all models**

Cylinder Capacity (tons)	Stroke (in)	Model Number	Cylinder Effective Area (in ²)	Oil Capacity (in ³)	Weight (lbs)
55	1.97	HLN5502	10.99	21.65	34.0
	3.94	HLN5504	10.99	43.27	44.5
	5.91	HLN5506	10.99	64.90	55.1
	7.87	HLN5508	10.99	86.54	65.9
	9.84	HLN5510	10.99	108.17	76.5
	11.81	HLN5512	10.99	129.80	87.1
100	1.97	HLN10002	20.57	40.49	67.2
	3.94	HLN10004	20.57	80.98	85.8
	5.91	HLN10006	20.57	121.48	104.3
	7.87	HLN10008	20.57	161.97	122.6
	9.84	HLN10010	20.57	202.46	141.1
	11.81	HLN10012	20.57	242.95	159.6
150	1.97	HLN15002	31.16	61.39	116.4
	3.94	HLN15004	31.16	122.79	145.0
	5.91	HLN15006	31.16	184.18	173.6
	7.87	HLN15008	31.16	245.27	202.1
	9.84	HLN15010	31.16	306.66	230.7
	11.81	HLN15012	31.16	368.05	259.3
200	1.97	HLN20002	41.0	80.7	181.0
	5.91	HLN20006	41.0	242.0	256.0
	7.87	HLN20008	41.0	323.0	293.0
	9.84	HLN20010	41.0	403.5	331.0

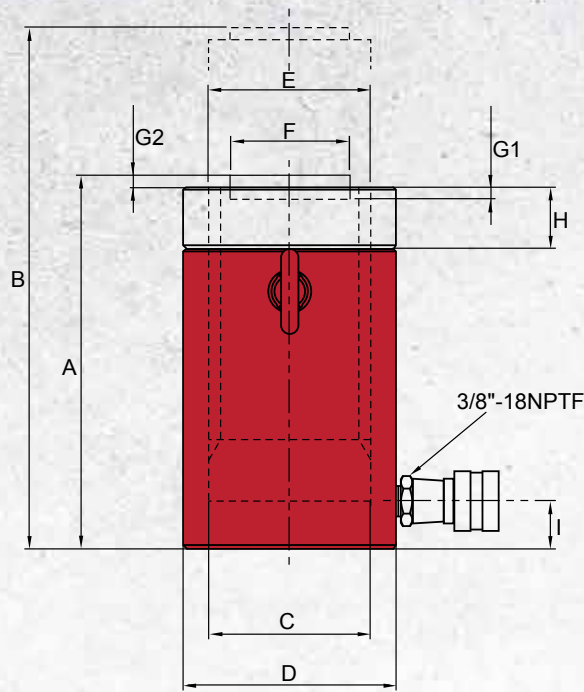

Model Number	Collapsed Height A (in)	Extended Height B (in)	Cylinder Bore Diameter C (in)	Outside Diameter D (in)	Rod Outside Thread E	Saddle Diameter F (in)	Depth of Rod Hole G1 (in)	Saddle Protrusion From Rod G2 (in)	Lock Nut Length H (in)	Base to Inlet Port I (in)
HLN5502	6.50	8.40	3.70	4.90	TW95-6N	2.80	0.51	0.08	1.40	1.10
HLN5504	8.40	12.40	3.70	4.90	TW95-6N	2.80	0.51	0.08	1.40	1.10
HLN5506	10.40	16.30	3.70	4.90	TW95-6N	2.80	0.51	0.08	1.40	1.10
HLN5508	12.40	20.20	3.70	4.90	TW95-6N	2.80	0.51	0.08	1.40	1.10
HLN5510	14.30	24.20	3.70	4.90	TW95-6N	2.80	0.51	0.08	1.40	1.10
HLN5512	16.30	28.10	3.70	4.90	TW95-6N	2.80	0.51	0.08	1.40	1.10
HLN10002	7.40	9.30	5.10	6.50	TW130-4N	2.80	0.51	0.08	1.80	1.10
HLN10004	9.30	13.30	5.10	6.50	TW130-4N	2.80	0.51	0.08	1.80	1.10
HLN10006	11.30	17.20	5.10	6.50	TW130-4N	2.80	0.51	0.08	1.80	1.10
HLN10008	13.30	21.10	5.10	6.50	TW130-4N	2.80	0.51	0.08	1.80	1.10
HLN10010	15.20	25.10	5.10	6.50	TW130-4N	2.80	0.51	0.08	1.80	1.10
HLN10012	17.20	29.00	5.10	6.50	TW130-4N	2.80	0.51	0.08	1.80	1.10
HLN15002	8.23	10.20	6.30	8.07	TW160-4N	5.12	0.51	0.08	1.73	1.54
HLN15004	10.20	14.13	6.30	8.07	TW160-4N	5.12	0.51	0.08	1.73	1.54
HLN15006	12.17	18.07	6.30	8.07	TW160-4N	5.12	0.51	0.08	1.73	1.54
HLN15008	14.13	22.01	6.30	8.07	TW160-4N	5.12	0.51	0.08	1.73	1.54
HLN15010	16.10	25.94	6.30	8.07	TW160-4N	5.12	0.51	0.08	1.73	1.54
HLN15012	18.07	29.88	6.30	8.07	TW160-4N	5.12	0.51	0.08	1.73	1.54
HLN20002	9.57	11.5	7.22	9.25	TW183.5-4N	5.12		0.08	1.97	1.97
HLN20006	13.50	19.5	7.22	9.25	TW183.5-4N	5.12		0.08	1.97	1.97
HLN20008	15.50	23.4	7.22	9.25	TW183.5-4N	5.12		0.08	1.97	1.97
HLN20010	17.40	27.3	7.22	9.25	TW183.5-4N	5.12		0.08	1.97	1.97

Low Profile Lock Nut Cylinders

- Single acting cylinder with mechanical safety lock nut
- Designed to support load for an extended period of time
- Low profile for confined spaces
- 5° tilting saddle is standard
- Maximum working pressure: 10,000 psi/700 bar
- Equipped with CH38F high flow coupler

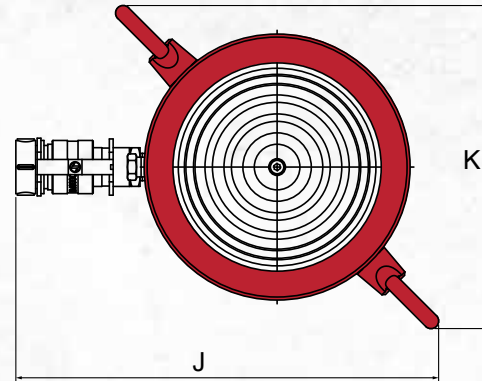
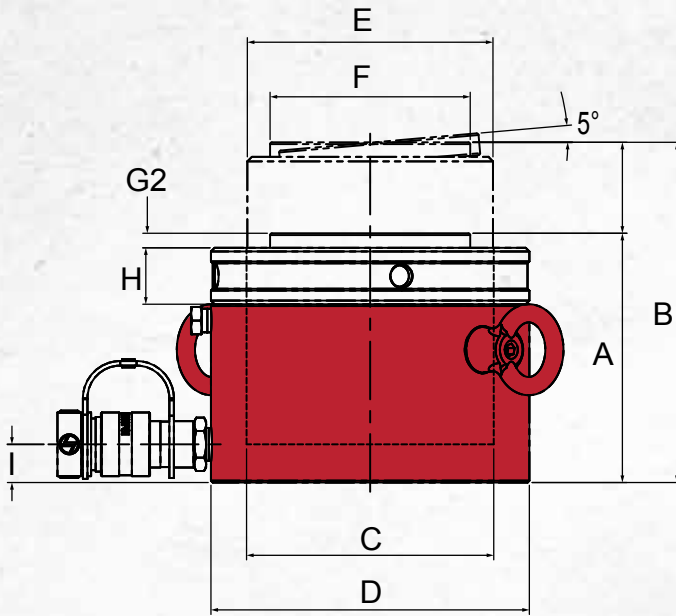

Cylinder Capacity (tons)	Stroke (in)	Model Number	Cylinder Effective Area (in ²)	Oil Capacity (in ³)	Weight (lbs)
60	1.97	HLNF6002	13.42	26.42	31.3
100	1.97	HLNF10002	22.47	44.23	54.1
160	1.77	HLNF16002	35.51	62.91	91
200	1.77	HLNF20002	43.95	77.86	118.6

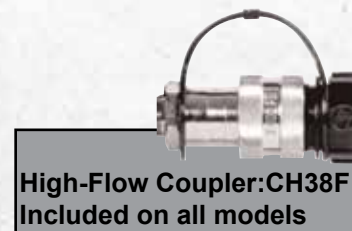

Model Number	Collapsed Height A (in)	Extended Height B (in)	Cylinder Bore Diameter C (in)	Outside Diameter D (in)	Rod Outside Thread E	Saddle Diameter F (in)	Saddle Protrusion From Rod G2 (in)	Lock Nut Length H (in)	Base to Inlet Port I (in)	Coupler to Eyelet J (in)	Eyelet to Eyelet K (in)
HLNF6002	4.92	6.89	4.13	5.51	TW105-4N	3.23	0.24	1.10	0.75	9.78	7.39
HLNF10002	5.39	7.36	5.35	6.89	TW135-4N	4.33	0.31	1.22	0.83	10.95	8.37
HLNF16002	5.83	7.60	6.72	8.66	TW170-4N	5.83	0.35	1.57	1.06	12.46	9.62
HLNF20002	6.10	7.87	7.48	9.66	TW190-4N	6.30	0.39	1.69	1.18	13.30	10.31

ALUMINUM CYLINDERS

- Lightweight aluminum alloy construction
- Up to 60 percent lighter than comparable tonnage steel cylinders
- Convenient carry handle
- Hard anodized aluminum rod provides extra protection against corrosion and wear
- Steel protective plate on cylinder base
- Maximum working pressure: 10,000 psi / 700 bar



Lightweight, yet powerful

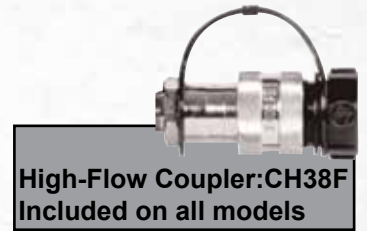
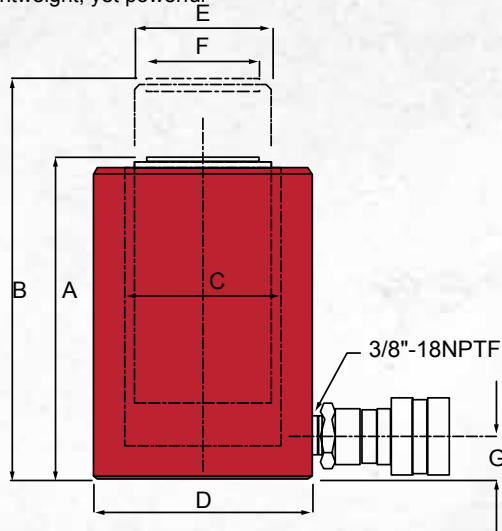

High-Flow Coupler:CH38F
Included on all models

Cylinder Capacity (tons)	Stroke (in)	Model Number	Cylinder Effective Area (in ²)	Internal Pressure at Capacity (psi)	Oil Capacity (in ³)	Collapsed Height A (in)	Extended Height B (in)	Cylinder Bore Dia. C (in)	Outside Dia. D (in)	Rod Dia. E (in)	Saddle Dia. F (in)	Base to Inlet Port G (in)	Weight (lbs)
20	1.97	HU2002T	4.83	10,000	9.51	6.85	8.82	2.48	3.35	2.00	1.56	1.08	7.4
	3.94	HU2004T	4.83	10,000	19.02	8.82	12.76	2.48	3.35	2.00	1.56	1.08	8.5
	5.91	HU2006T	4.83	10,000	28.53	10.79	16.69	2.48	3.35	2.00	1.56	1.08	9.6
30	2.00	HU3002T	6.50	9,231	13.00	6.50	8.50	2.90	4.50	2.50	2.00	1.50	11.0
	4.00	HU3004T	6.50	9,231	26.00	8.50	12.50	2.90	4.50	2.50	2.00	1.50	14.0
	6.00	HU3006T	6.50	9,231	39.00	10.50	16.50	2.90	4.50	2.50	2.00	1.50	17.0
50	2.00	HU5002T	11.00	9,091	22.00	6.50	8.50	3.70	5.50	3.10	2.50	150	17.0
	4.00	HU5004T	11.00	9,091	44.00	8.50	12.50	3.70	5.50	3.10	2.50	150	21.0
	6.00	HU5006T	11.00	9,091	66.00	10.50	16.50	3.70	5.50	3.10	2.50	150	25.0
	10.00	HU5010T	11.00	9,091	110.00	14.50	24.50	3.70	5.50	3.10	2.50	150	34.0
75	4.00	HU7504	15.00	10,000	60.00	8.50	12.50	4.40	6.50	3.90	3.00	150	29.0
	6.00	HU7506	15.00	10,000	90.00	10.50	16.50	4.40	6.50	3.90	3.00	150	35.0
100	2.00	HU10002	20.70	9,662	41.40	6.50	8.50	5.10	8.00	4.30	3.50	150	36.0
	4.00	HU10004	20.70	9,662	82.80	8.50	12.50	5.10	8.00	4.30	3.50	150	43.0
	6.00	HU10006	20.70	9,662	124.40	10.50	16.50	5.10	8.00	4.30	3.50	150	51.0
	10.00	HU10010	20.70	9,662	207.0	14.50	24.50	5.10	8.00	4.30	3.50	150	68.0

HOLLOW HOLE CYLINDERS

- Minimum leak risk
- Ideal for pulling and pushing applications
- Heavy duty compression spring
- Dual wipers help prevent contamination
- Collar thread protector
- High flow coupler with dust cap
- XT cylinders do not come with internal rod threads
- 60 and 100 Ton models are equipped with carrying handles

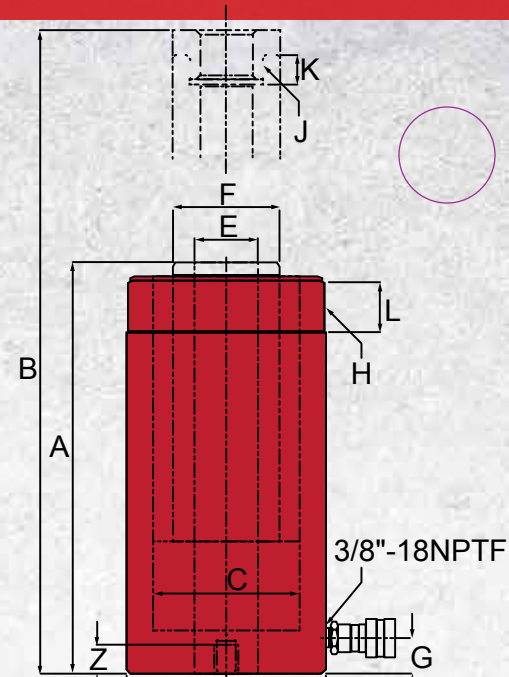
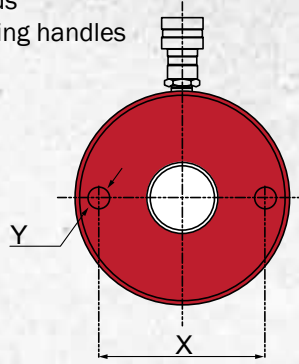

Cylinder Capacity (tons)	Stroke (in)	Model Number	Cylinder Effective Area (in ²)	Internal Pressure at Capacity (psi)	Oil Cap. (in ³)	Weight (lbs)	Min. Height A (in)	Max. Height B (in)	Bore Dia C (in)	O.D. D (in)
12	0.31	HC1201T*	2.91	8,236	0.89	3.3	2.36	2.67	1.92	2.76
	1.61	HC1202T*	2.91	8,236	4.70	6.2	4.74	6.36	1.92	2.76
	1.61	HC1202XT*	2.91	8,236	4.70	6.2	4.74	6.36	1.92	2.76
	2.99	HC1203XT	2.91	8,236	8.72	8.6	7.24	10.24	1.92	2.76
20	2.01	HC2002T	4.90	8,167	9.83	15.9	6.38	8.39	2.5	3.92
	6.06	HC2006T	4.90	8,167	29.70	29.5	12.05	18.11	2.5	3.92
30	2.52	HC3002T	6.32	9,488	15.93	22.9	7.05	9.57	2.84	4.50
	6.11	HC3006T	6.32	9,488	38.67	43.0	13.02	19.13	2.84	4.50
60	3.00	HC6003T ±	13.05	9,195	39.10	65.7	9.77	12.77	4.08	6.25
	6.00	HC6006T ±	13.05	9,195	78.25	81.1	12.76	18.76	4.08	6.25
100	3.00	HC10003T ±	22.13	9,036	66.31	113.3	10.00	13.00	5.31	8.39



± Cylinder are equipped with carrying handles

Model Number	Rod				Collar Thread		Base to Inlet Port G (in)	Base Mounting Hole		
	I.D. E (in)	O.D. F (in)	Internal Thread J (in)	Internal Thread Length K (in)	Dia. H (in)	Lgth. L (in)		Bolt Circle X (in)	Thread Y (in)	Thread Depth Z (in)
HC1201T*	0.77	1.38	3/4"-16UN	0.63	2 3/4"-16	1.81	0.57	2.00	5/16"-18UNC	0.35
HC1202T*	0.77	1.38	3/4"-16UN	0.63	2 3/4"-16	1.81	0.59	2.00	5/16"-18UNC	0.35
HC1202XT*	0.77	1.38	-	-	2 3/4"-16	1.81	0.59	2.00	5/16"-18UNC	0.35
HC1203XT	0.77	1.38	-	-	2 3/4"-16	1.81	0.75	2.00	5/16"-18UNC	0.35
HC2002T	1.06	2.15	1-9/16"-16UN	0.75	3 7/8"-12	1.50	0.75	3.25	3/8"-16UNC	0.37
HC2006T	1.06	2.15	1-9/16"-16UN	0.75	3 7/8"-12	1.50	0.75	3.25	3/8"-16UNC	0.37
HC3002T	1.31	2.48	1-13/16"-16UN	0.87	4 1/2"-12	1.66	0.91	3.62	3/8"-16UNC	0.55
HC3006T	1.31	2.48	1-13/16"-16UN	0.87	4 1/2"-12	1.66	0.91	3.62	3/8"-16UNC	0.55
HC6003T	2.13	3.66	2 3/4"-16UN	0.75	6 1/4"-12	1.91	1.06	5.12	1/2"-13UNC	0.55
HC6006T	2.13	3.66	2 3/4"-16UN	0.75	6 1/4"-12	1.91	1.06	5.12	1/2"-13UNC	0.55
HC10003T	3.11	4.92	4"-16UN	0.98	8 3/8"-12	2.38	1.06	7.01	5/8"-11UNC	0.75

*except HC1201T, HC1202T, and HC1202XT come with CRZ14F

DOUBLE ACTING HOLLOW HOLE CYLINDERS

- Ideal for pushing and pulling applications.
- Dual wipers help prevent contamination
- Collar thread protector
- 3/8" high flow female coupler.

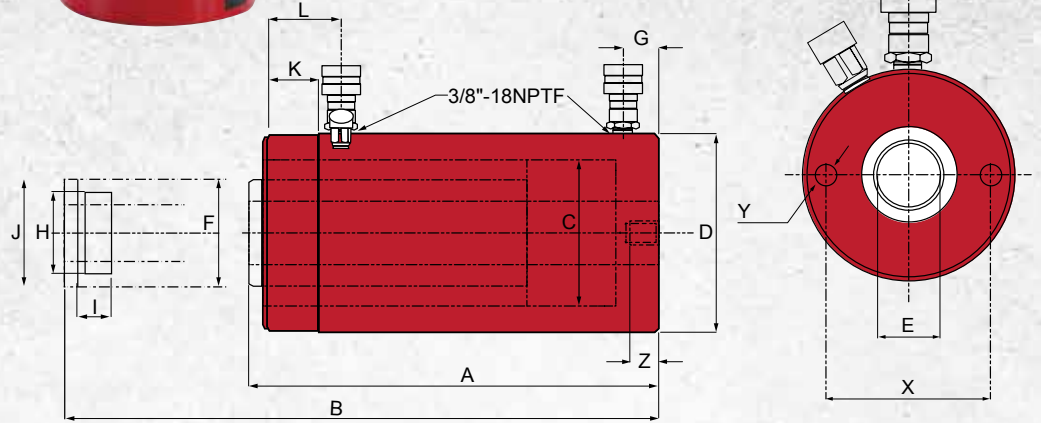

**High-Flow Coupler:CH38F
Included on all models**

Cylinder Capacity		Stroke (in)	Mode Number	Oil Capacity		Collapsed Height (in)	Extended Height (in)	Center Hole I.D. (in)	Rod O.D (in)	Max. Pressure (PSI)	Product Weight (Lbs.)
Push (ton)	Pull (ton)			Push (in ³)	Pull (in ³)						
30	20	7.00	HDC3007	44.31	27.74	13.02	20.02	1.31	2.48	10,000	43.0
		10.13	HDC3010	64.15	40.16	17.00	27.13	1.31	2.48	10,000	56.7
60	44	3.50	HDC6003	45.75	30.49	9.77	13.28	2.13	3.62	10,000	65.7
		6.50	HDC6006	84.81	56.53	12.76	19.26	2.13	3.62	10,000	81.1
		10.12	HDC6010	132.10	88.04	17.25	27.37	2.13	3.62	10,000	112.4
100	71	1.50	HDC10001	33.23	21.18	6.50	8.00	3.11	4.92	10,000	73.7
		3.00	HDC10003	66.47	42.37	10.00	13.00	3.11	4.92	10,000	113.3
		6.00	HDC10006	132.39	84.73	13.49	19.49	3.11	4.92	10,000	153.2
		10.13	HDC10010	224.52	143.11	18.14	28.27	3.11	4.92	10,000	198.9
150	82.8	8.00	HDC15008	259.19	132.44	13.75	21.75	3.94	5.91	10,000	239.2

Mode Number	Min. Height A (in)	Max. Height B (in)	Dia. of Center Tube C (in)	O.D D (in)	I.D. E(in)	O.D. F (in)	Base to Inlet Port G (in)	Top to Return Port L (in)	Internal Thread H (in)	Internal Thread Length I (in)	Collar Thread		Base Mounting Hole		
											Dia. J (in)	Length K (in)	Bolt Circle X (in)	Thread Y (in)	Thread Depth Z (in)
HDC3007	13.02	20.02	3.35	4.50	1.31	2.48	0.91	2.38	1 13/16"-16UN	0.94	4 1/2"-12	1.66	3.62	3/8"-16UNC	0.55
HDC3010	17.00	27.13	3.35	4.50	1.31	2.48	0.91	2.38	1 13/16"-16UN	0.94	4 1/2"-12	1.66	3.62	3/8"-16UNC	0.55
HDC6003	9.77	13.28	4.92	6.25	2.13	3.62	1.06	2.64	2 3/4"-16UN	0.83	6 1/4"-12	1.91	5.12	1/2" 13UNC	0.55
HDC6006	12.76	19.26	4.92	6.25	2.13	3.62	1.06	2.64	2 3/4"-16UN	0.83	6 1/4"-12	1.91	5.12	1/2" 13UNC	0.55
HDC6010	17.25	27.37	4.92	6.25	2.13	3.62	1.06	2.64	2 3/4"-16UN	0.83	6 1/4"-12	1.91	5.12	1/2" 13UNC	0.55
HDC10001	6.50	8.00	6.50	8.39	3.11	4.92	1.06	1.75	4"- 16UN	1.06	-	-	7.01	5/8" 11UNC	0.75
HDC10003	10.00	13.00	6.50	8.39	3.11	4.92	1.06	3.39	4"- 16UN	1.06	8 3/8"-12	2.38	7.01	5/8" 11UNC	0.75
HDC10006	13.49	19.49	6.50	8.39	3.11	4.92	1.06	3.39	4"- 16UN	1.06	8 3/8"-12	2.38	7.01	5/8" 11UNC	0.75
HDC10010	18.14	28.27	6.50	8.39	3.11	4.92	1.06	3.39	4"- 16UN	1.06	8 3/8"-12	2.38	7.01	5/8" 11UNC	0.75
HDC15008	13.75	21.75	7.48	9.75	3.94	5.91	1.50	2.38	-	-	-	-	-	-	-

FLAT BODY CYLINDERS

- Made of high quality steel
- Extremely low collapsed height for applications with minimal clearance at the lift point
- Maximum working pressure 10,000 psi / 700 bar
- HF0503 and HF0503B come with 3/8" regular flow coupler



**High-Flow Coupler:CH38F
Included on all models**

*except HF0503 comes with CR38F

Cylinder Capacity (tons)	Stroke (in)	Model Number	Cylinder Effective Area (in ²)	Pressure at Capacity	Oil Capacity (in ³)	Weight (lbs)
5	0.24	HF0503*	1.10	9,090	0.26	1.3
10	0.43	HF1005	2.36	8,470	1.01	3.3
20	0.43	HF2005	4.38	9,130	1.88	5.9
30	0.51	HF3005	6.49	9,240	3.31	9.7
50	0.63	HF5006	9.86	10,140	6.21	14.9
75	0.63	HF7506	16.1	9,320	10.14	25.4
100	0.63	HF10006	19.64	10,180	12.37	31.5
150	0.63	HF15006	30.67	9,780	19.32	53.4

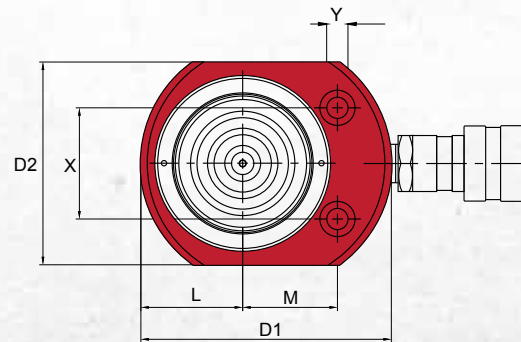
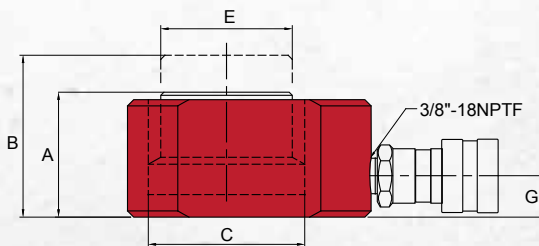

Model Number	Col-lapsed Height A (in)	Ex-extended Height B (in)	Cylinder Bore Dia. C (in)	Outside Dim. D1 x D2 (in)	Rod Dia. E (in)	Base to Port G (in)	Rod to Base L (in)	Rod to Mtg. Hole M (in)	Hole Pitch X (in)	Hole Dia. Y (in)	Counter Bore Dia. (in)	Counter Bore Depth (in)
HF0503*	1.26	1.50	1.18	2.4x1.6	0.98	0.69	0.80	0.87	1.12	0.2	0.31	0.17
HF1005	1.69	2.12	1.73	3.3x2.2	1.50	0.77	1.12	1.32	1.44	0.28	0.42	0.31
HF2005	2.01	2.44	2.36	4.0x3.0	2.00	0.75	1.54	1.56	1.94	0.40	0.59	0.39
HF3005	2.31	2.82	2.87	4.6x3.8	2.50	0.79	1.88	1.75	2.06	0.40	0.63	0.44
HF5006	2.64	3.27	3.54	4.5x4.5	2.76	0.79	2.25	2.13	2.62	0.43	0.75	0.50
HF7506	3.13	3.76	4.53	6.5x5.5	3.54	0.77	2.75	2.63	3.00	0.51	0.83	0.56
HF10006	3.37	4.00	5.00	7.0x6.0	3.54	0.79	3.00	2.94	3.00	0.51	0.83	0.56
HF15006	3.94	4.57	6.25	8.5x7.5	4.65	0.94	3.75	3.25	4.62	0.51	0.83	0.56

FLAT BODY CYLINDER KITS

- Various height magnetic adapters eliminate dangerous cribbing
- Convenient carrying case
- Magnetic adapters are stackable
- U.S. Patent No.7,237,762 B2

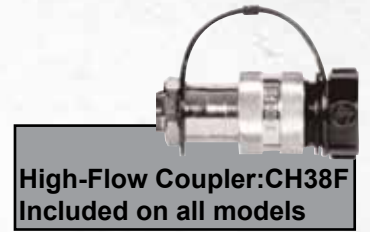
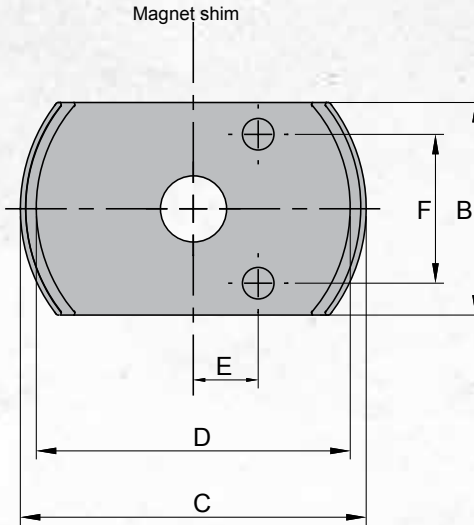
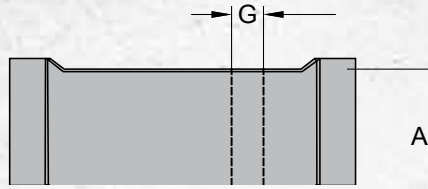

**High-Flow Coupler:CH38F
Included on all models**

*except HF0503B come with CR38F

Cylinder Capacity (tons)	Stroke (in)	Model Number	Cylinder Model	Oil Capacity (in ³)	Collapsed Height (in)	Adapter	Adapter Dimensions							Weight (lbs)
							A (in)	B (in)	C (in)	D (in)	E (in)	F (in)	G (in)	
5	0.24	HF0503B*	HF0503	0.26	1.26	I	0.17	1.61	2.56	2.32	0.48	1.10	0.24	5.5
						II	0.42	1.61	2.56	2.32	0.48	1.10	0.24	5.5
						III	0.92	1.61	2.56	2.32	0.48	1.10	0.24	5.5
						IV	1.17	1.61	2.56	2.32	0.48	1.10	0.24	5.5
10	0.43	HF1005B	HF1005	1.02	1.69	I	0.39	2.20	3.54	3.23	0.81	1.46	0.28	9.2
						II	0.79	2.20	3.54	3.23	-	-	-	9.2
						III	1.57	2.20	3.54	3.23	-	-	-	9.2
20	0.43	HF2005B	HF2005	1.90	2.01	I	0.39	2.99	4.25	3.94	1.08	1.93	0.39	15.0
						II	0.79	2.99	4.25	3.94	-	-	-	15.0
						III	1.57	2.99	4.25	3.94	-	-	-	15.0
30	0.51	HF3005B	HF3005	3.32	2.31	I	0.39	3.75	4.76	4.45	1.32	2.06	0.39	21.0
						II	0.79	3.75	4.76	4.45	-	-	-	21.0
						III	1.57	3.75	4.76	4.45	-	-	-	21.0
50	0.63	HF5006B	HF5006	3.32	2.31	I	0.39	4.49	5.89	5.57	1.61	2.62	0.43	32.32
						II	0.79	4.49	5.89	5.57	-	-	-	32.32
						III	1.57	4.49	5.89	5.57	-	-	-	32.32

LOW PROFILE CYLINDERS

- Compact design for use in confined spaces
- Rod wiper helps seal out dirt and contamination
- Specially designed return spring provides quick retraction and extends the life of the spring
- Industrial hard chrome plated rod helps prevent scratching and corrosion
- Rod end is grooved to reduce load slippage
- Includes high flow coupler and dust cap
- HL1001, HL2002, and HL3002 coupler is tilted upward for added clearance
- Maximum working pressure: 10,000 psi / 700 bar



HL10002 with welded handle

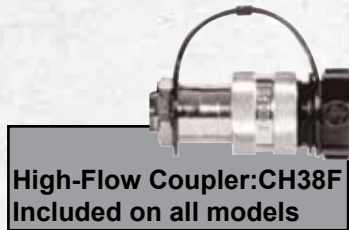

High-Flow Coupler:CH38F Included on all models



Low profile cylinders are great for confined spaces

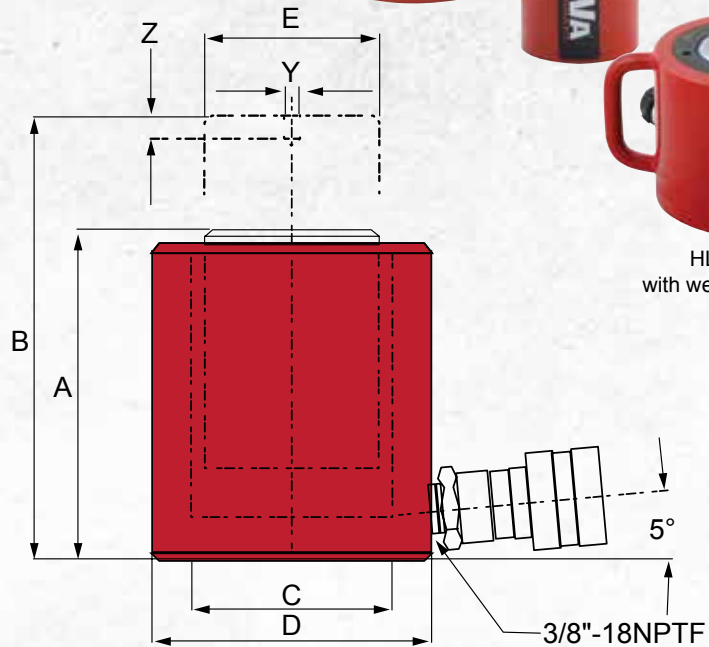

Cylinder Capacity (tons)	Stroke (in)	Model Number	Cylinder Effective Area (in ²)	Internal Pressure at Capacity (psi)	Oil Capacity (in ³)	Weight (lbs)
10	1.50	HL1001	2.35	8,511	3.53	5.7
20	1.75	HL2002	4.37	9,153	7.65	11.0
30	2.44	HL3002	6.49	9,245	15.84	15.0
50	2.36	HL5002	9.87	10,132	23.29	21.8
100	2.24	HL10002	19.64	10,183	44.07	45.4

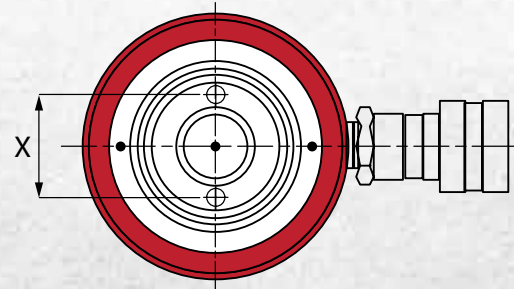

Model Number	Collapsed Height A (in)	Extended Height B (in)	Cylinder Bore Diameter C (in)	Outside Diameter D (in)	Rod Diameter E (in)	Rod Mounting		
						Bolt Circle X (in)	Thread Y (mm)	Thread Depth Z (in)
HL1001	3.48	4.98	1.73	2.75	1.50	1.03	M4	0.32
HL2002	3.90	5.65	2.36	3.63	2.00	1.56	M4	0.32
HL3002	4.61	7.05	2.87	4.00	2.50	1.56	M5	0.32
HL5002	4.80	7.17	3.54	4.88	2.76	1.56	M5	0.32
HL10002	5.55	7.80	5.00	6.50	3.54	2.19	M8	0.10

LOW PROFILE CYLINDER KIT

- Compact design for use in confined spaces
- Ideal for pushing applications
- Rod wiper helps seal out dirt and contamination
- Specially designed return spring ensures a quick retraction and extends the life of the spring
- Industrial hard chrome plated rod helps prevent scratching and corrosion
- Includes stackable 1", 2", and 3" aluminum adapters that conveniently snap into the base of the rod
- Includes high flow ball coupler and dust cap
- Convenient storage case to keep cylinder and adapters together



**High-Flow Coupler: CH38F
Included on all models**

Cylinder Capacity	Model Number	Stroke	Cylinder Effective Area	Collapsed Height	Extended Height without adapter	Internal Pressure at Capacity	Cylinder Housing Dia.	Rod Dia.	Weight (lbs)
10 Ton	J72101	1.5"	2.35 in ²	3.48"	4.98"	8,511 PSI	2.75"	1.50"	10 Lbs.

LOAD CELLS

- Hydraulic load cells are available with either a direct mounted scale or the gauge attached to a 6' hose
- Designed for load testing



Type	Model Number	Maximum Capacity Lbs.
Directly Mounted Scale	LC1001	20,000
	LC2002	40,000
	LC5002	100,000
	LC10002	200,000
With Hydraulic Hose	LCH1001	20,000
	LCH2002	40,000
	LCH5002	100,000
	LCH10002	200,000

HIGH TONNAGE SINGLE ACTING CYLINDERS

- Cylinders are burnish rolled for a smooth precision mirror finish.
- Rod wiper seals out dirt and contamination
- Base mounting holes on all models
- Load return
- High strength steel construction from gun drilled solid bar
- High flow 3/8" NPTF couplers
- Polyurethane cup seal provides optimum performance
- Industrial hard chrome plated rod helps prevent rust and corrosion
- Solid steel cylinder body provides strength for high tonnage applications
- Maximum working pressure: 10,000 psi / 700 bar



Load Return

Cylinder Capacity (tons)	Stroke (in)	Model Number	Cylinder Effective Area (in ²)	Internal Pressure at Capacity (psi)	Oil Capacity (in ³)	Weight (lbs)
100	1.97	HG10002	20.57	9723	40.5	61.0
	3.94	HG10004	20.57	9723	81.00	74.1
	7.87	HG10006	20.57	9723	121.5	87.3
	9.84	HG10008	20.57	9723	161.99	100.4
	11.81	HG10012	20.57	9723	242.99	126.7
150	1.97	HG15002	30.43	9862	59.89	102.4
	3.94	HG15004	30.43	9862	119.78	122.0
	5.91	HG15006	30.43	9862	179.68	141.8
	7.87	HG15008	30.43	9862	239.57	161.6
	9.84	HG15010	30.43	9862	299.46	181.4
200	11.81	HG15012	30.43	9862	359.35	201.7
	1.97	HG20002	40.99	9761	80.68	121.0
	5.91	HG20006	40.99	9761	242.05	201.0
	7.87	HG20008	40.99	9761	322.73	242.0
	11.81	HG20012	40.99	9761	484.10	322.0



High-Flow Coupler: CH38F
Included on all models

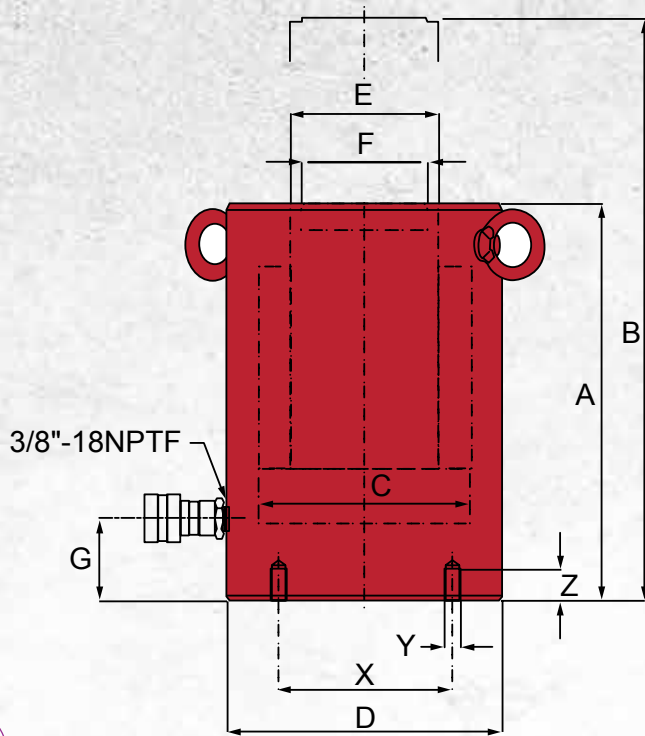

Model Number	Collapsed Height A (in)	Extended Height B (in)	Cylinder Bore Diameter C (in)	Outside Diameter D (in)	Rod Diameter E (in)	Saddle Diameter F (in)	Base to Inlet Port G (in)	Base Mounting Hole		
								Bolt Circle X (in)	Thread Y (mm)	Thread Depth Z (in)
HG10002	7.17	9.13	5.12	6.50	3.74	2.95	2.13	3.74	M12	0.87
HG10004	9.13	13.07	5.12	6.50	3.74	2.95	2.13	3.74	M12	0.87
HG10006	11.10	17.01	5.12	6.50	3.74	2.95	2.13	3.74	M12	0.87
HG10008	13.07	20.94	5.12	6.50	3.74	2.95	2.13	3.74	M12	0.87
HG10012	17.01	28.82	5.12	6.50	3.74	2.95	2.13	3.74	M12	0.87
HG15002	7.72	9.69	6.22	8.07	4.33	3.70	2.40	5.12	M12	0.87
HG15004	9.69	13.62	6.22	8.07	4.33	3.70	2.40	5.12	M12	0.87
HG15006	11.65	17.56	6.22	8.07	4.33	3.70	2.40	5.12	M12	0.87
HG15008	13.62	21.50	6.22	8.07	4.33	3.70	2.40	5.12	M12	0.87
HG15010	15.59	25.43	6.22	8.07	4.33	3.70	2.40	5.12	M12	0.87
HG15012	17.56	29.37	6.22	8.07	4.33	3.70	2.40	5.12	M12	0.87
HG20002	8.50	10.47	7.22	9.25	5.31	4.45	2.62	6.5	M12	0.87
HG20006	12.44	18.35	7.22	9.25	5.31	4.45	2.62	6.5	M12	0.87
HG20008	14.41	22.28	7.22	9.25	5.31	4.45	2.62	6.5	M12	0.87
HG20012	18.35	30.16	7.22	9.25	5.31	4.45	2.62	6.5	M12	0.87

HIGH TONNAGE DOUBLE ACTING CYLINDERS (HDG Series)

- Cylinders are burnish rolled for a smooth precision mirror finish
- Industrial hard chrome plated rod prevents scratching and corrosion
- Base mounting holes standard on all models
- Rod wiper seals out dirt and contamination
- High strength steel construction from gun drilled solid bar
- High flow 3/8" NPTF couplers
- Maximum working pressure: 10,000 psi / 700 bar



**High-Flow Coupler:CH38F
Included on all models**

Cylinder Capacity (tons)	Stroke (in)	Model Number	Maximum Cylinder Capacity		Cylinder Effective Area		Oil Capacity		Weight (lbs)
			Push (ton)	Pull (ton)	Push (in ²)	Pull (in ²)	Push (in ³)	Pull (in ³)	
100	1.97	HDG10002	102.86	47.93	20.57	9.59	40.50	18.87	61.0
	3.94	HDG10004	102.86	47.93	20.57	9.59	81.00	37.74	74.1
	5.91	HDG10006	102.86	47.93	20.57	9.59	121.50	56.61	87.3
	7.87	HDG10008	102.86	47.93	20.57	9.59	161.99	75.49	100.4
	9.84	HDG10010	102.86	47.93	20.57	9.59	202.49	94.36	113.6
	11.81	HDG10012	102.86	47.93	20.57	9.59	242.99	113.23	126.7
150	1.97	HDG15002	152.11	78.49	30.43	15.70	59.89	30.90	102.4
	3.94	HDG15004	152.11	78.49	30.43	15.70	119.78	61.79	122.0
	5.91	HDG15006	153.90	75.00	30.43	14.96	181.75	88.32	141.8
	7.87	HDG15008	152.11	78.49	30.43	15.70	239.57	123.59	161.6
	9.84	HDG15010	152.11	78.49	30.43	15.70	299.46	154.48	181.4
	11.81	HDG15012	152.11	78.49	30.43	15.70	359.35	185.38	201.7
200	1.97	HDG20002	204.92	94.02	40.99	18.80	80.68	37.01	121.0
	5.91	HDG20006	206.10	98.00	40.99	19.68	243.40	116.23	201.0
	7.87	HDG20008	204.92	94.02	40.99	18.80	322.73	148.03	242.0
	11.81	HDG20012	206.10	98.00	40.99	19.68	486.79	232.46	322
300	5.91	HDG30006	353.60	117.00	70.71	23.46	417.56	138.55	511
400	11.81	HDG40012	433.90	150.00	86.79	29.99	1025.00	354.18	928
500	5.91	HDG50006	566.30	192.00	113.25	38.37	668.77	226.61	1,058

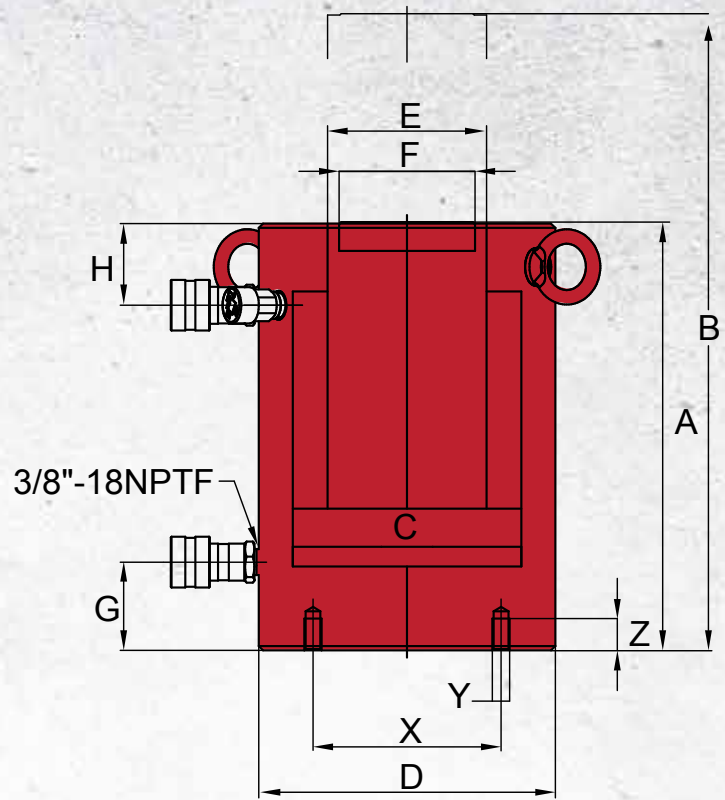

Model Number	Col-lapsed Height A (in)	Extend-ed Height B (in)	Cylinder Bore Dia. C (in)	Outside Dia. D (in)	Rod Dia. E (in)	Sad-dle Dia. F (in)	Base to Adv. Port G (in)	Top to Return Port H (in)	Base Mounting Hole		
									Bolt Circle X (in)	Thread Y (mm)	Thread Depth Z (in)
HDG10002	7.17	9.13	5.12	6.50	3.74	2.95	2.13	1.89	3.74	M12	0.87
HDG10004	9.13	13.07	5.12	6.50	3.74	2.95	2.13	1.89	3.74	M12	0.87
HDG10006	11.10	17.01	5.12	6.50	3.74	2.95	2.13	1.89	3.74	M12	0.87
HDG10008	13.07	20.94	5.12	6.50	3.74	2.95	2.13	1.89	3.74	M12	0.87
HDG10010	15.04	24.88	5.12	6.50	3.74	2.95	2.13	1.89	3.74	M12	0.87
HDG10012	17.01	28.82	5.12	6.50	3.74	2.95	2.13	1.89	3.74	M12	0.87
HDG15002	7.72	9.69	6.22	8.07	4.33	3.70	2.40	2.22	5.12	M12	0.87
HDG15004	9.69	13.62	6.22	8.07	4.33	3.70	2.40	2.22	5.12	M12	0.87
HDG15006	11.65	17.56	6.22	8.07	4.33	3.70	2.40	2.22	5.12	M12	0.87
HDG15008	13.62	21.50	6.22	8.07	4.33	3.70	2.40	2.22	5.12	M12	0.87
HDG15010	15.59	25.43	6.22	8.07	4.33	3.70	2.40	2.22	5.12	M12	0.87
HDG15012	17.56	29.37	6.22	8.07	4.33	3.70	2.40	2.22	5.12	M12	0.87
HDG20002	8.50	10.47	7.22	9.25	5.31	4.45	2.62	2.22	6.50	M12	0.87
HDG20006	12.44	18.35	7.24	9.25	5.31	4.45	2.62	2.22	6.50	M12	0.87
HDG20008	14.41	22.28	7.22	9.25	5.31	4.45	2.62	2.22	6.50	M12	0.87
HDG20012	18.35	30.16	7.24	9.25	5.31	4.45	2.62	2.22	6.50	M12	0.87
HDG30006	16.22	22.13	9.49	12.20	7.76	6.97	3.98	2.95	7.09	M16	1.42
HDG40012	24.59	36.40	10.51	13.78	8.50	7.72	4.49	4.13	8.07	M16	1.42
HDG50006	20.43	26.34	12.01	15.75	9.76	8.98	4.49	5.31	9.84	M24	1.50

HIGH TONNAGE DOUBLE ACTING CYLINDERS (HD Series)

- Rod wiper seals out dirt and contamination
- High strength steel construction from gun drilled solid bar
- High flow 3/8" NPTF couplers
- One piece high grade alloy bearing for side load protection and long life
- Ideal for pushing and pulling
- Maximum working pressure: 10,000 psi / 700 bar
- Threaded cylinders, removable saddle, thicker cylinder walls (than HDG series)

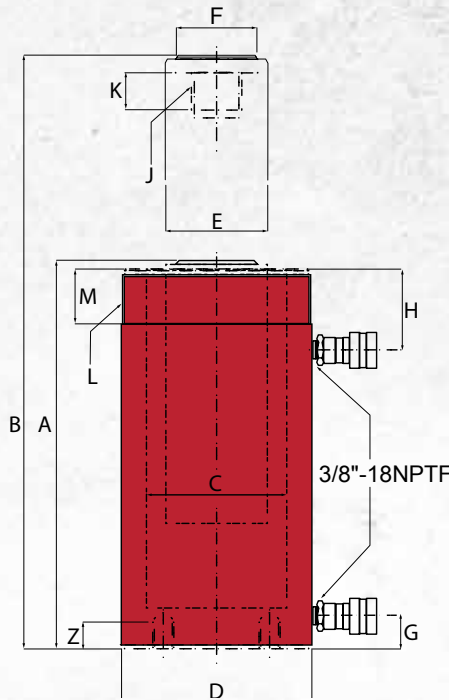
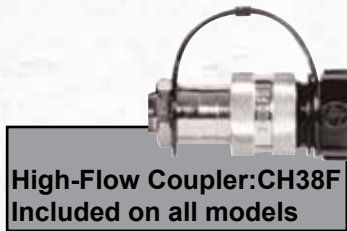

Cylinder Capacity (tons)	Stroke (in)	Model Number	Maximum Cylinder Capacity		Cylinder Effective Area		Oil Capacity		Collapsed Height A (in)	Extended Height B (in)	Cylinder Bore Dia. C (in)	Outside Dia. D (in)
			Push (ton)	Pull (ton)	Push (in ²)	Pull (in ²)	Push (in ³)	Pull (in ³)				
200	6.00	HD20006	221.00	112.50	44.21	22.50	265.28	135.00	16.94	22.94	7.50	9.75
	13.00	HD20013	221.00	112.50	44.21	22.50	574.78	293.00	23.13	36.13	7.50	9.75
	24.00	HD20024	221.00	112.50	44.21	22.50	1061.00	528.00	36.13	60.13	7.50	9.75
300	6.00	HD30006	354.60	190.00	70.93	38.00	425.56	228.00	19.13	25.13	9.50	12.25
500	6.00	HD50006	565.70	315.00	113.15	63.00	678.92	378.00	22.75	28.75	12.00	15.63

Model Number	Rod Dia. E (in)	Saddle Dia. F (in)	Base to Adv. Port G (in)	Top to Return Port H (in)	Collar Thread L (in)	Collar Thread Length M (in)	Rod Internal Thread J (in)	Rod Thread Length K (in)	Base Mounting Hole			Weight (lbs)
									Bolt Circle X (in)	Thread Y (in)	Thread Depth Z (in)	
HD20006	5.25	5.25	2.25	3.81	-	-	-	-	5.00	1-8	1.00	325.00
HD20013	5.25	5.25	2.25	3.81	9¼-12	2.13	2½-12	2.50	5.00	1-8	1.00	440.00
HD20024	5.25	5.25	3.38	4.00	9¼-12	2.13	2½-12	2.50	5.00	1-8	1.00	616.00
HD30006	6.50	6.50	3.50	4.50	12¼-12	2.31	2½-12	3.25	6.25	1¼-7	1.75	441.00
HD50006	8.00	8.00	4.75	6.00	15¾-8	3.13	3¼-12	4.25	8.00	1¼-5	2.12	953.00

PULL CYLINDERS

- High strength steel construction
- One piece high grade alloy bearing for side load protection and longer life
- Polyurethane cup seal helps provide for optimum performance
- External rod threads
- Internal base threads
- Used for pulling and tensioning
- Maximum working pressure: 10,000 psi / 700 bar

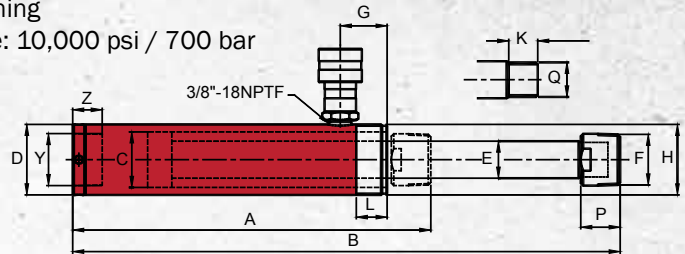
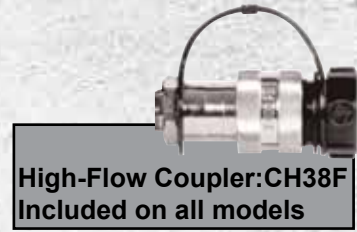

Cylinder Capacity (tons)	Stroke (in)	Model Number	Cylinder Effective Area (in ²)	Internal Pressure at Capacity (psi)	Oil Capacity (in ³)	Collapsed Height A (in)	Extended Height B (in)	Outside Diameter D (in)	Cylinder Bore Diameter C (in)	Top to Inlet Port G (in)	Collar	
											Thread H	Thread Length L (in)
2.5	5.00	HP0205	0.56	7,905	2.78	10.55	15.55	1.89	1.13	1.65	1½"-16	0.98
5	5.55	HP0505	1.14	8,772	6.34	11.93	17.48	2.25	1.69	1.50	2¼"-14	1.00
10	5.95	HP1006	2.44	7,663	14.48	11.75	17.70	3.35	2.17	1.50	M85x2	1.00

Model Number	Adapter		Rod			Base Mounting Hole		Weight (lbs)
	Thread F (in)	Length P (in)	Dia. E (in)	Thread Length K (in)	Thread Q (mm)	Thread Y	Depth Z (in)	
HP0205	¾"-14NPTF	1.13	0.75	0.76	M16 x 1.5	¾"-14NPTF	0.72	6.4
HP0505	1¼"-11.5NPTF	1.25	1.18	0.93	M28 x 1.5	1¼"-11.5NPTF	0.95	9.3
HP1006	-	-	1.26	1.02	M30 x 2	M30x2	0.98	20.9

THREADED CYLINDERS

- Ideal for frode pulling machine
- High quality threaded single acting cylinders
- Spring return
- Removable threaded Rod adapter allows for the use of a variety of threaded attachments
- Used to attach accessories to rod end and base
- Maximum working pressure: 10,000 psi / 700 bar

Threaded base allows for easy installation of attachments and mounting applications



Cylinder Capacity (tons)	Stroke (in)	Model Number	Cylinder Effective Area (in ²)	Internal Pressure at Capacity (psi)	Oil Capacity (in ³)
4	5.07	HT0405*	1.00	10,120	5.00
10	5.95	HT1006	2.24	8,928	13.33
	9.96	HT1010	2.24	8,928	22.30
20	5.16	HT2005	5.14	10,741	25.70

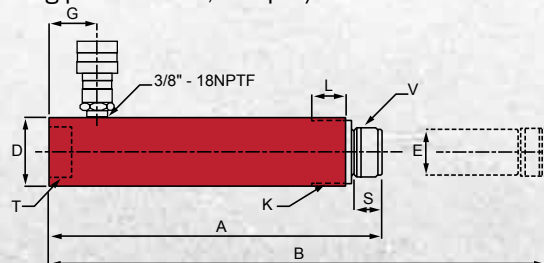

High-Flow Coupler: CH38F
Included on all models

*HT0405 come with CRZ14F

Collapsed Height A (in)	Extended Height B (in)	Outside Dia. D (in)	Rod Dia. E (in)	Base to Inlet Port G (in)	Collar K	Collar Thread Length L (in)	Saddle Height S (in)	Base Threads T (in)	Rod Threads V (in)	Weight (lbs)
10.31	15.39	1.5	1.33	1.33	1.5"-16UNF	0.94	1.00	¾" - 14 NPSM	¾" - 14 NPTF	5.0
11.46	17.41	2.26	1.49	1.67	2.25"-14UNC	1.13	0.94	1.25" -11.5 NPSM	1.25" -11.5 NPSM	10.6
15.47	25.43	2.26	1.49	1.67	2.25"-14UNC	1.13	0.94	1.25" -11.5 NPSM	1.25" -11.5 NPSM	14.1
11.77	16.93	3.35	2.24	1.85	3-3/8"-12~UNC	1.98	1.40	2" -11.5 NPSM	2" -11.5 NPSM	22.0

PRECISION DOUBLE ACTING CYLINDERS

- Provides hydraulic power on both advance and retract
- Designed for high cycling in production applications
- High strength steel construction from gun drilled solid bar
- Rod wiper seals keep dirt and contamination out
- Clevis eye attachments are available
- Maximum working pressure : 10,000 psi / 700 bar

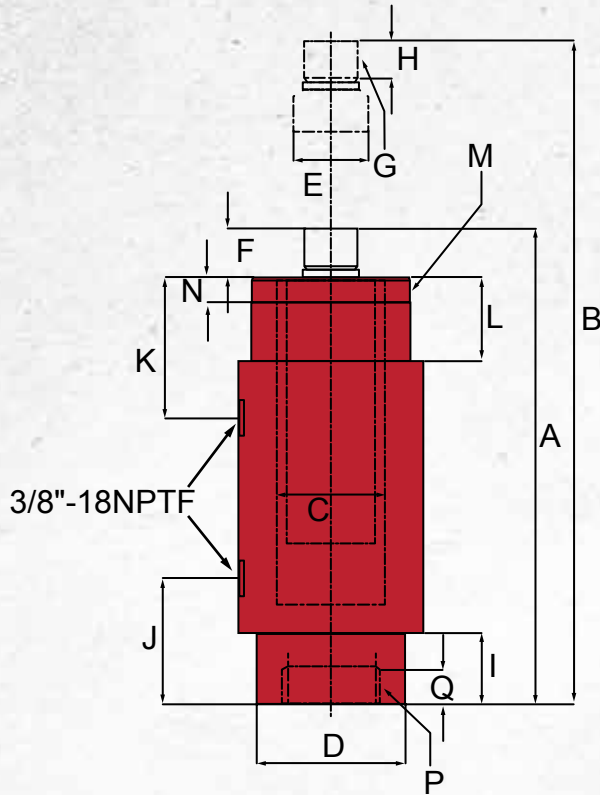

*** Note: Precision double acting cylinders do not come with couplers.**

Cylinder Capacity (tons)	Model Number	Push Effective Area (in ²)	Pull Effective Area (in ²)	Collapsed Height A (in)	Extended Height B (in)	Cylinder Bore Dia. C (in)	Outside Dia. D (in)
9	HPD0906	1.77	1.01	13.78	19.88	1.50	2.52
	HPD0910	1.77	1.01	17.80	27.91	1.50	2.52
16	HPD1606	3.14	1.56	15.31	21.57	2.00	2.99
	HPD1610	3.14	1.56	19.29	29.53	2.00	2.99



Model Number	Rod				Base to Adv. Port J (in)	Top to Return Port K (in)	Collar					Weight (lbs)
	Dia. E (in)	Protrusion F (in)	Thread G (in)	Thread Length H (in)			Length L (in)	Thread M (in)	Thread Length N (in)	Int. Base Thread P (in)	Int. Base Thread Length Q (in)	
HPD0906	0.98	0.98	3/4"-16	0.75	1.50	2.20	1.50	2"-12	0.60	1-11/16"-18	1.37	14.6
HPD0910	0.98	0.98	3/4"-16	0.75	1.50	2.20	1.50	2"-12	0.60	1-11/16"-18	1.37	18.5
HPD1606	1.42	1.16	1 1/8"-12	0.98	2.12	2.87	2.12	2 5/8"-16	0.98	2-3/16"-16	1.61	22.0
HPD1610	1.42	1.16	1 1/8"-12	0.98	2.12	2.87	2.12	2 5/8"-16	0.98	2-3/16"-16	1.61	28.2

CYLINDER ACCESSORIES

CYLINDER LIFTING HANDLES

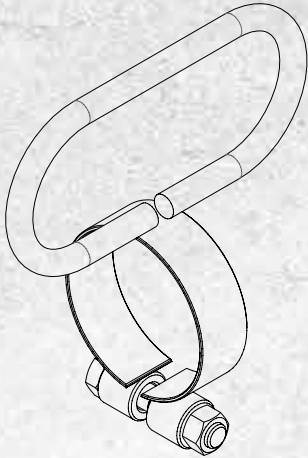

- Designed for ease of carrying
- Provides better control for positioning cylinder

Model Number	For Cylinders
LH25T34	H2504 through H2514
LH30T40	H3008, HD3008, HD3014, HC2002T, HC2006T
LH30T45	HC3002T, HC3006T, HD3007, HDC3010
LH55T49	HLN5504 through HLN5512

CLEVIS AND TANGS

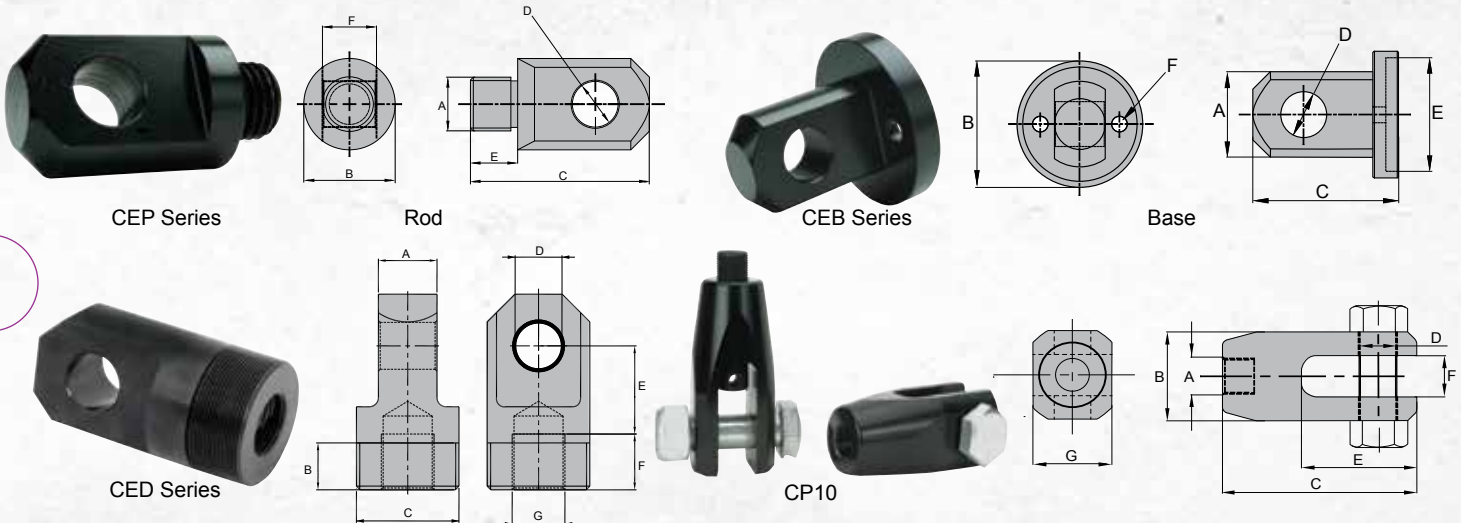

Application	For use with Cylinder Capacity (tons)	Model Number	Dimensions (in)						
			A	B	C	D	E	F	G
Rod	5	CEP05	¼"-16UNF	1.13	2.25	0.63	0.62	0.56	-
	10	CEP10	1"-8UNC	1.69	3.31	0.88	0.75	1.00	-
	15	CEP15	1"-8UNC	1.69	3.31	0.88	0.75	1.00	-
	25	CEP25	1½"-16	2.25	3.81	1.25	0.87	1.50	-
Base	5	CEB05	1.52	1.75	2.13	0.63	0.26	1.13	-
	10	CEB10	2.28	2.50	2.87	0.88	1.69	0.32	-
	15	CEB15	2.77	3.00	2.87	0.88	1.69	0.38	-
	25	CEB25	3.40	3.75	3.37	1.25	2.25	0.56	-
Rod & Base	9	CED09	1	1	1-11/16"-18	0.75	1.31	0.94	¼"-16
	16	CED16	1.25	1	2-3/16"-16	1	1.88	1.19	1½"-12
	HP1006 only	CP10*	M30x2	2.95	6.30	1.18	3.74	1.38	2.56

* 2-pc set with an adapter

BASES

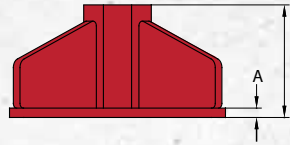
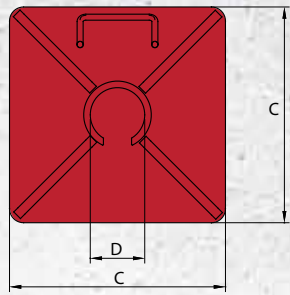

For use with Cylinder Capacity (tons)	Model Number	Dimensions (in)			
		A	B	C	D
5	CB05	0.32	4.65	7.87	1.54
10	CB10	0.39	4.72	9.06	2.28
15	CB15	0.47	4.80	10.00	2.76
25	CB25	0.63	4.96	11.02	3.41

SADDLES



SD SERIES



SDT10



HTD10

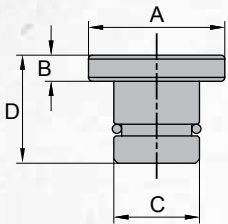

FIGURE #1

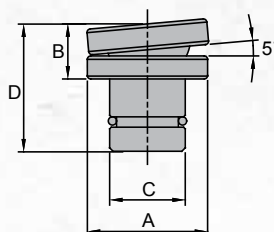

FIGURE #2

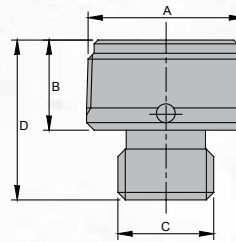

FIGURE #3

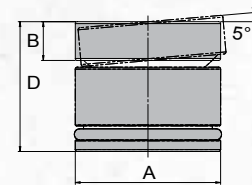

FIGURE #4

Saddle Type	Model Number	Capacity (ton)	For Cylinder(s)	Dimensions (in)				Figure Number
				A	B	C	D	
Tilt	SDT05	5	H05	0.98	1.22	-	0.63	2
	SDT10	10	H10	1.38	1.50	-	0.74	2
	SDT15	15	H15	1.50	1.57	-	0.73	2
	SDT25	25	H25	1.97	1.6	-	1.29	2
	SDT55	55-100	H55, HD55, H75, HD75, H100, HLN55 and HLN100	2.80	1.29	0.67	0.51	2
	SDTG100	100	HG100/HDG100	2.95	2.64	1.71	0.79	4
	SDTG150	150	HG150/HDG150	3.70	2.71	1.77	0.77	4
	SDTG200	200	HG200/HDG200	4.45	3.25	1.95	1.10	4
Grooved	SDT200	200	HLN 150/HLN200	5.12	1.77	1.02	0.53	4
	SD05	5	H05	0.98	0.81	-	0.24	1
	SD10	10	H10	1.38	1.06	-	0.24	1
	SD15	15	H15	1.50	1.18	-	0.28	1
Threaded	SD25	25	H25	1.97	1.14	-	0.28	1
	HTD10	10	HT1006 & HT1010	1 1/4"-11.5NPTF	0.95	1"-8UNC	1.77	3

PUMP / CYLINDER COMBO

• Each combo set includes all components need to power connect and monitor system pressure

Each Set Includes:

- 3/8", 6 Foot Hydraulic Hose (CS3838)
- Gauge Adapter (CF3814)
- 4" Wet Gauge (GW4014)
- 3/8" High Flow Male Coupler (CH38M)
- Cylinder (see chart below)
- Pump (see chart below)



Type	Combo Capacity (Ton)	Cylinder			Combo Model Number						
		Model	Stroke (in)	Collapsed Height (in)	With Hand Pump			With Air Pump			
					Model P350	Model P1000	Model P2001	Model PA1500	Model PA1500L	Model PA3801	
Single Acting Cylinders	5	H0505	5.08	8.70	SP3-0505						
	10	H1002	2.01	4.84		SP10-1002			SA15-1002		
		H1004	4.02	6.85		SP10-1004			SA15-1004		
		H1006	5.94	9.84		SP10-1006			SA15-1006	SAL15-1006	
		H1010	9.96	13.86		SP10-1010			SA15-1010	SAL15-1010	
		HT1006	5.95	11.46		SP10-1006T			SA15-1006T	SAL15-1006T	
		HT1010	9.96	15.47		SP10-1010T			SA15-1010T	SAL15-1010T	
	15	H1504	3.86	8.66		SP10-1504			SA15-1504		
		H1506	5.87	10.67		SP10-1506			SA15-1506		
	25	H2502	2.01	6.82		SP10-2502			SA15-2502		
		H2504	3.94	8.78		SP10-2504			SA15-2504		
		H2506	5.94	10.79		SP10-2506			SA15-2506		
		H2508	7.95	12.80			SP20-2508	SA15-2508			
			H2514	14.25	18.74			SP20-2514	SA15-2514		
55	H5506	6.25	11.13			SP20-5506	SA15-5506				
100	H10006	6.63	13.25							SA38-10006	
Single Acting Flat Body Cylinder	5	HF0503B	0.24	1.26	SP3-0503B						
	10	HF1005B	0.43	1.69	SP3-1005B						
Single Acting Hollow Hole Cylinder	12	HC1201T	0.31	2.36	SP3-1201T						
		HC1202XT	1.61	4.74	SP3-1202XT						
		HC1203XT	2.99	7.24		SP10-1203XT					
	20	HC2002T	2.01	6.38		SP10-2002T			SA15-2002T		
	30	HC3006T	6.11	13.02		SP10-3006T			SA15-3006T		
	100	HC10003T	3.00	10.00			SP20-10003T			SA15-10003T	
Single Acting Low Profile Cylinder	60	HC6003T	3.00	9.77		SP10-6003T			SA15-6003T		
	50	HL5002	2.36	4.80		SP10-5002L			SA15-5002L		
100	HL10002	2.24	5.55		SP10-10002L			SA15-10002L			

HYDRAULIC PUMPS

HAND PUMP & AIR PUMP MODEL NUMBER MATRIX

PA1500L

P **A** 1500 **L**

Options for pumps:

- A** - External pressure adjustment (1,000-10,000 psi)
- B** - Mounting holes on the base of the reservoir
- H** - Hand control
- L** - Remote control valve for air pumps
- M** - 4 way control valve for for double acting cylinders
- S** - Single speed pumps (Hand pumps only)

Pump Type

- A** - Air over hydraulic
- AR** - Rotary pump
- ARD** - Auto return valve

Hydraulic Pump

Reservoir Size

350 - 21.4 in ³	1500 - 91.5 in ³	3801 - 231.9 in ³
601 - 36.5 in ³	2000 - 122.1 in ³	4301 - 250 in ³
1000 - 61 in ³	2001 - 122 in ³	7550 - 460.6 in ³
1201 - 67 in ³	2301 - 128 in ³	8701 - 476 in ³



ELECTRIC PUMP MODEL NUMBER MATRIX

PEM1503T-230V50

PE **M** 15 **03** **T** -230V50

Options for electric pumps:

- **230V50** 230 volts, 50 Hz electric motors*
- **FP2** Foot pedal for PESL and PESML models
- **FP1** Foot pedal for PEW and PEWM models
- **W** Wireless remote control for PESL and PESML models
- **15** cord - 15' remote cord for PEW(M) and PES(M)L models
- **3** phase electric motor §
- **A** external pressure adjustment, 10,000 PSI max

TECO Motor

Teco-Westinghouse Motor

Reservoir Size

01 - 1 gallon	06 - 6 gallons △
02 - 2 gallons	10 - 10 gallons
03 - 3 gallons	15 - 15 gallons
05 - 5 gallons	25 - 25 gallons

Motor Options & Oil Output at 10,000 PSI

05 - ½ hp, 18 cubic inches
10 - 1 hp, 37 cubic inches
15 - 1½ hp, 61 cubic inches
30 - 3 hp, 110 cubic inches

Valve Options

- M** - Double acting cylinders (hydraulic return)
- W** - Pendant switch controls the motor, manual valve, 10' cord
- L** - Locking plate for manual valves. Can be used with PEW pumps
- SL** - Hand held remote controls the solenoid valve with locking plate, 10' cord
- D** - Auto return valve or dump valve
- DS** - Solenoid auto return valve

Motor Type

PE - Electric industrial induction motor

* Please add the plug type on the PO if different from North American plug-socket configuration.
C, D, E, F, G, H, I, J, K, L, M, N
§ Three phase motors will accept 230 volts, 50 or 60 Hz electrical supply.
△ For 3 Phase motors only



METAL AIR PUMPS

- High strength reinforced alloy reservoir is lightweight and corrosion resistant
- U.S. Patent No.5,946,912, a built-in by-pass device protects hydraulic system from over pumping damage
- A compact yet powerful Air Turbo Motor U.S. Patent No.5,341,723 is equipped to raise the load to the desired height efficiently, effortlessly, and safely
- Suggested air pressure range: 110-175 psi / 7.5-12 bar
- Dust cover protection for the release control valve
- Maximum working pressure: 10,000 psi / 700 bar

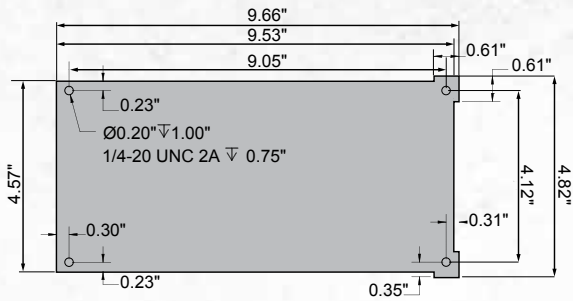

Flow Rate@ 110 PSI Air Pressure

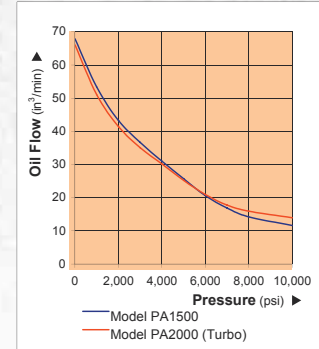

Air pumps can be used in a variety of industrial settings

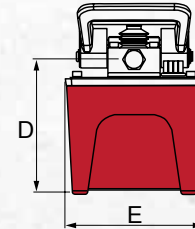
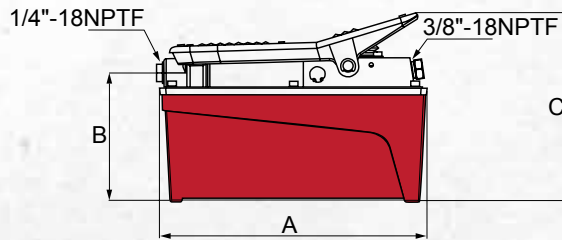

Used with Cylinder	Usable Oil Capacity (in³)	Model Number	Pressure Rating (psi)	Oil Output Flow Rate (in³/min)		Input Air Pressure Range (psi)	Dimensions (in)					Weight (lbs)
				No Load	Load		A	B	C	D	E	
Single Acting	91.5	PA1500A±	10,000	66	11	110-175	10.35	5.00	7.28	5.16	5.35	18.1
	91.5	PA1500	10,000	66	11	110-175	10.35	5.00	7.28	5.16	5.35	18.1
	91.5	PA1500B*	10,000	66	11	110-175	10.35	5.00	7.28	5.16	5.35	18.1
	122.1	PA2000	10,000	65	12	110-175	11.57	6.02	7.91	6.18	5.98	20.1
	231.9	PA3801	10,000	65	11	110-175	12.64	5.08	7.36	5.24	7.36	27.1
	231.9	PA3801-HP12	12,000	65	9	110-145	2.64	5.08	7.36	5.24	7.36	27.1
	460.6	PA7550	10,000	65	11	110-175	12.64	5.00	8.31	6.14	8.43	36.0

* Note: PA1500B comes with base mounting holes.
± External pressure adjustment 1,000-10,000 psi

DOUBLE ACTING AIR PUMP

- High strength metal reservoir is durable and corrosion resistant.
- Suggested air pressure range: 110-175 psi (7.5 – 12 bar)
- Maximum working pressure: 10,000 psi (700 bar)



PA1500M

- PA1500M offers a 4-way control valve for operation of double acting cylinders

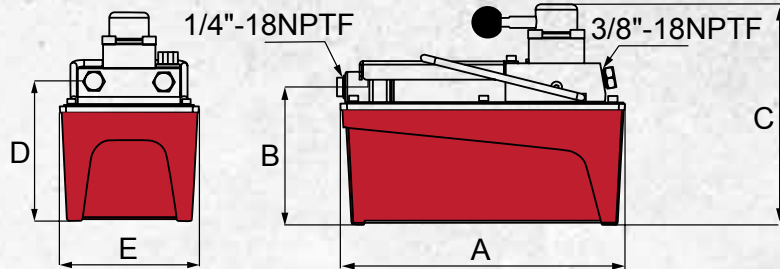

Used with Cylinder	Usable Oil Capacity (in ³)	Model Number	Pressure Rating (psi)	Oil Output Flow Rate (in ³ /min)		Input Air Pressure Range (psi)	Dimensions (in)					Weight (lbs)
				No Load	Load		A	B	C	D	E	
Double Acting	91.5	PA1500M	10,000	66	11	110-175	10.51	5.00	7.99	5.35	5.35	19.1
	231.9	PA3801M	10,000	65	11	110-175	12.64	5.04	8.03	5.31	7.36	65.0
	460.6	PA7550M	10,000	65	11	110-175	12.64	5.98	9.02	6.34	10.04	40.0

REMOTE CONTROL AIR PUMPS

- 10 ft. hand held remote allows user to operate the air pump from a safe distance
- Air pump comes with convenient carry handle



PA1500L



PA3801L

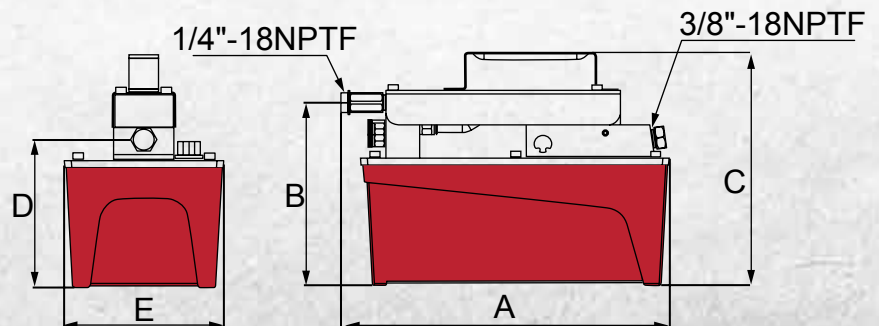

Used with Cylinder	Usable Oil Capacity (in ³)	Model Number	Pressure Rating (psi)	Oil Output Flow Rate (in ³ /min)		Input Air Pressure Range (psi)	Dimensions (in)					Weight (lbs)
				No Load	Load		A	B	C	D	E	
Single Acting	91.5	PA1500L	10,000	61	10	110-175	10.98	6.30	8.03	5.12	5.35	19.4
	231.9	PA3801L	10,000	61	10	110-175	12.64	6.42	8.15	5.20	7.36	30.4

ROTARY AIR PUMPS

- Two speed operation for fast cylinder advance and improved productivity
- Models available with auto return valve
- Internal relief valves for overload protection
- Ideal for application in areas where combustible material or gases are present

Rotary Air Pump Flow Chart

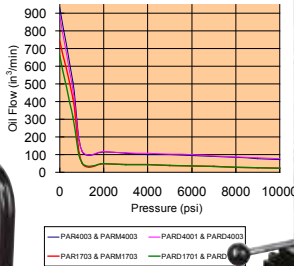

PARD1703



PAR4003

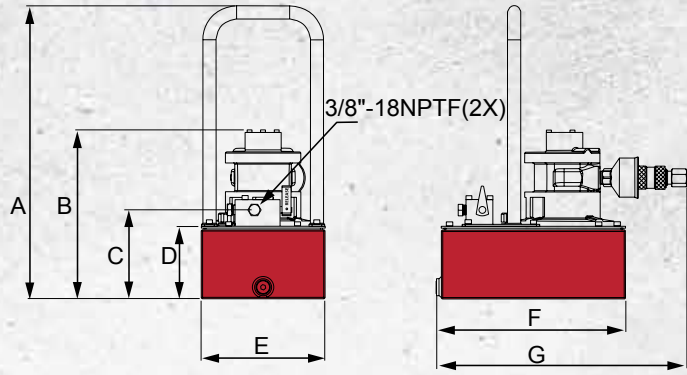

PARD1703

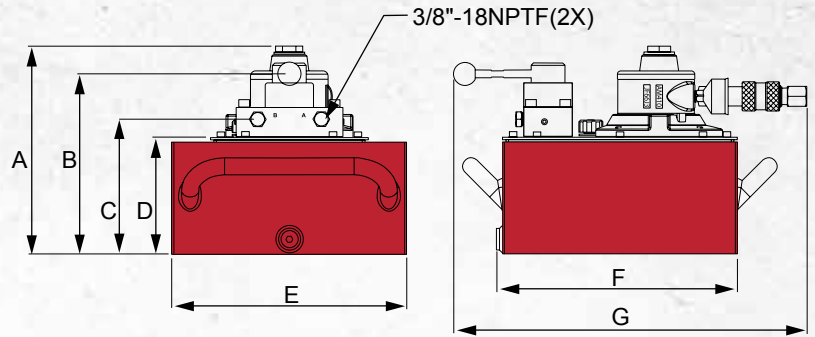

PAR4003

Used with Cylinder	Motor Size (hp)	Usable Oil Capacity (gal)	Model Number	Pressure Rating (psi)	Pressure Rating		Oil Output Flow Rate		Valve Type	Valve Function	Air pressure range (psi)
					1st Stage (psi)	2nd Stage (psi)	1st Stage (in³/min)	2nd Stage (in³/min)			
Single Acting	1.7	1	PARD1701	10,000	700	10,000	313	22	Dump	Advance/Return	60 ~ 80
	1.7	3	PARD1703	10,000	700	10,000	313	22	Dump	Advance/Return	60 ~ 80
	1.7	3	PAR1703	10,000	700	10,000	417	22	Manual PW3	Advance/Hold/Return	60 ~ 80
	4	1	PARD4001	10,000	700	10,000	465	70	Dump	Advance/Return	60 ~ 100
	4	3	PARD4003	10,000	700	10,000	465	70	Dump	Advance/Return	60 ~ 100
	4	3	PAR4003	10,000	700	10,000	512	70	Manual PW3	Advance/Hold/Return	60 ~ 100
Double Acting	1.7	3	PARM1703	10,000	700	10,000	417	22	Manual PW4	Advance/Hold/Return	60 ~ 80
	4	3	PARM4003	10,000	700	10,000	512	70	Manual PW4	Advance/Hold/Return	60 ~ 100

Model Number	Air Consumption (cfm)	Sound Level (dBA)	Dimensions (in)							Weight (lbs)
			A	B	C	D	E	F	G	
PARD1701	44	93	19.10	9.39	5.79	4.72	8.07	12.34	15.90	42
PARD1703	44	93	-	11.95	8.35	7.28	12.01	12.34	17.96	54
PAR1703	44	93	11.94	10.53	8.21	7.28	12.01	12.34	18.08	55
PARD4001	95	100	19.10	11.00	5.79	4.72	8.07	12.34	16.34	54
PARD4003	95	100	-	13.56	8.35	7.28	12.01	12.34	18.4	66
PAR4003	95	100	13.55	10.53	8.21	7.28	12.01	12.34	18.52	67
PARM1703	44	93	11.94	10.53	8.21	7.28	12.01	12.34	18.08	55
PARM4003	95	100	13.55	10.53	8.21	7.28	12.1	12.34	18.52	67



ALL POSITION AIR PUMPS

- Pump can work in any position
- Mounting plate allows for the pump to be securely fastened
- Hydraulic port swivels for easy connection



PA600



PA600H

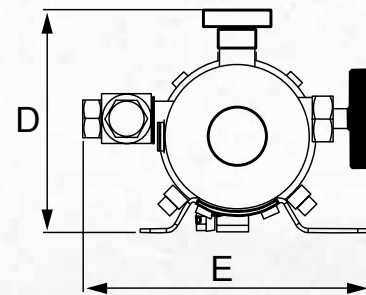
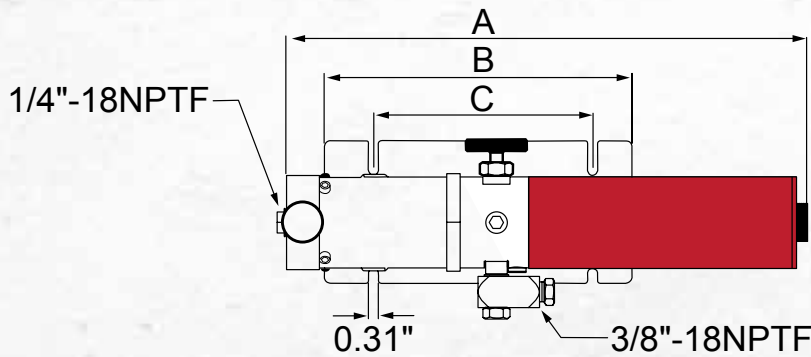

Used with Cylinder	Usable Oil Capacity (in ³)	Model Number	Pressure Rating (psi)	Oil Output Flow Rate (in ³ /min)		Input Air Pressure Range (psi)	Weight (lbs)
				No Load	Load		
Single Acting	36.6	PA600	10,000	61	9	110-175	14.1
	36.6	PA600H	10,000	61	9	110-175	12.5

Model Number	Dimensions (in)				
	A	B	C	D	E
PA600	16.77	9.84	7.01	6.18	5.59
PA600H	16.77	9.84	7.01	4.49	5.75

SINGLE SPEED METAL HAND PUMPS

- All metal reservoirs resist cracks and leaks
- Internal pressure relief valve for overload protection
- Wireless option for pumps
- Solid metal valve release knob



P601S

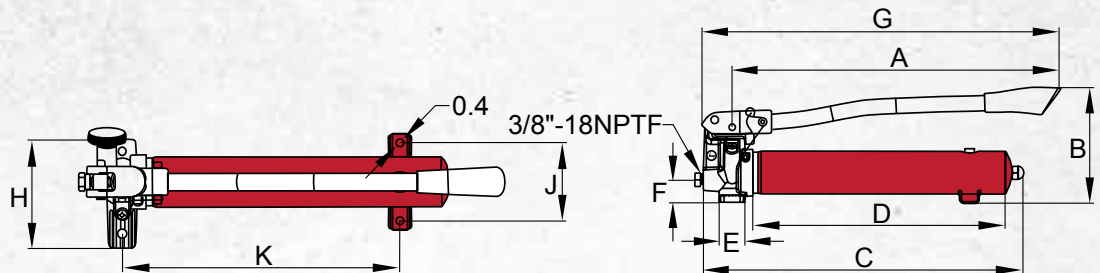

P1201S

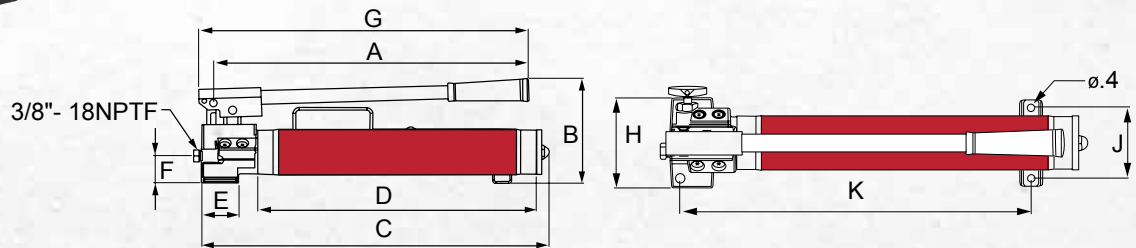

Used with Cylinder	Pump Type	Usable Oil Capacity (in ³)	Model Number	Pressure Rating (psi)	Oil Displacement per Stroke	Max. Operating Force (lbs)	Piston Stroke (in)	Oil Outlet Port	Weight (lbs)
Single Acting	Single Speed	36.5	P601S	10,000	0.15	109	0.79	3/8"-18NPTF	13.0
		67.0	P1201S	10,000	0.13	89	0.82	3/8"-18NPTF	20.0

Model Number	Dimensions (in)									
	A	B	C	D	E	F	G	H	J	K
P601S	18.94	6.46	19.53	15.35	1.57	1.26	20.79	5.20	3.74	14.45
P1201S	21.73	6.73	23.07	3.74	1.06	1.73	21.73	5.31	3.74	18.27

LOW PRESSURE HAND PUMP

- Lightweight and portable for use with punch drivers
- Rugged steel pump with chrome handle
- Single speed
- Mounting bracket for easy, permanent mounting
- Maximum working pressure 7,200 psi

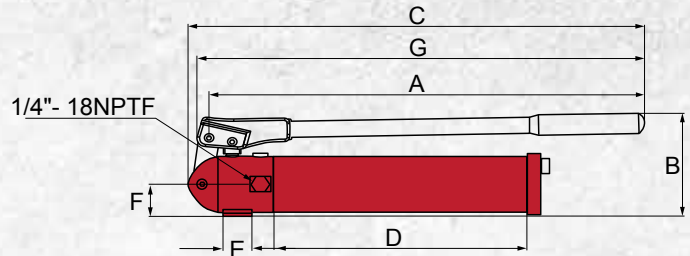
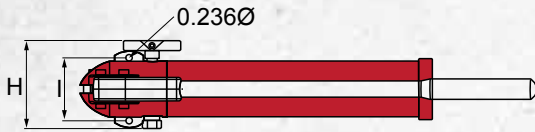

Used with Cylinder	Pump Type	Usable Oil Capacity (in ³)	Model Number	Pressure Rating (psi.)	Oil Displacement per Stroke (in ³)	Max. Operating Force (lbs)	Piston Stroke (in)	Oil Outlet Port	Weight (lbs)
Single Acting	Low Pressure Single Speed	14.7	P240L	7,200	0.09	55.7	0.63	1/4" - 18 NPTF	9.02

Model Number	Dimensions (in)									
	A	B	C	D	E	F	G	H	J	
P240L	14.80	4.250	15.45	8.675	1.00	12.50	15.250	3.50	2.437	



TWO SPEED ALUMINUM ALL DIRECTION HAND PUMP

- Lightweight aluminum alloy for easy handling
- Pump will operate in all positions for ease of use
- Can be securely mounted on equipment
- Solid metal valve release knob

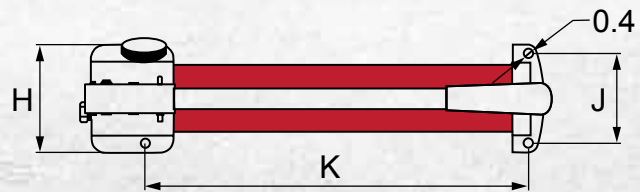
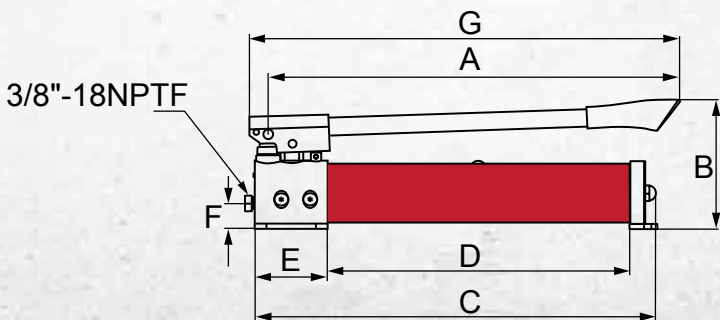

Used with Cylinder	Pump Type	Usable Oil Capacity (in ³)	Model Number	Pressure Rating		Oil Displacement per Stroke		Max. Operating Force (lbs)	Piston Stroke (in)	Oil Outlet Port	Weight (lbs)
				1st Stage (psi)	2nd Stage (psi)	1st Stage (in ³)	2nd Stage (in ³)				
Single Acting	Two Speed	53-62*	P1000AD	200	10,000	0.81	0.14	99	0.82	3/8"-18NPTF	13.7

Model Number	Dimensions (in)										
	A	B	C	D	E	F	G	H	J	K	
P1000AD	21.77	6.34	23.03	14.96	3.59	1.26	19.96	4.88	3.94	16.93	

*Oil capacity varies by positioning, capacity range: 53-62

TWO SPEED ALUMINUM HAND PUMPS

- Lightweight aluminum alloy for easy handling
- Two speed operation increases productivity and reduces user fatigue
- Internal pressure relief valve for overload protection
- Wireless option for pumps
- Solid metal valve release knob

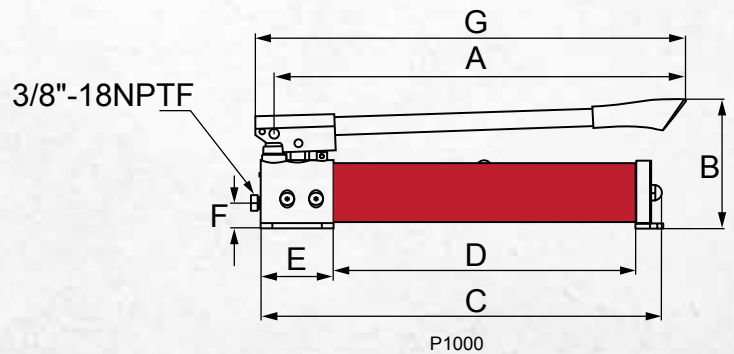
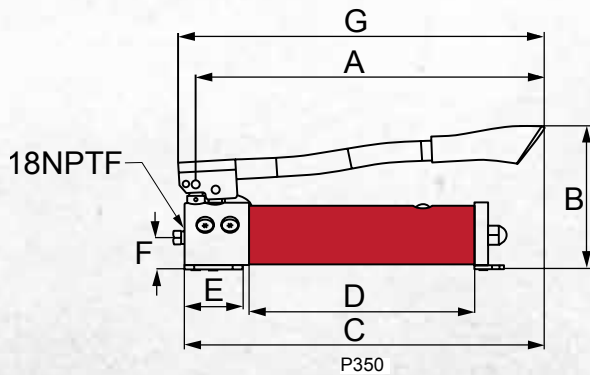
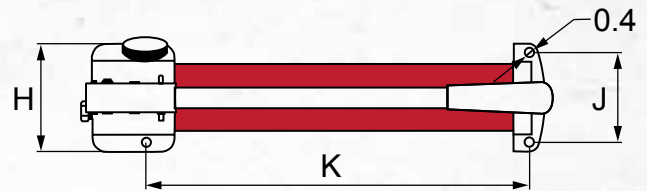
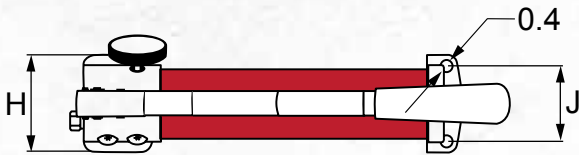

Used with Cylinder	Pump Type	Usable Oil Capacity (in ³)	Model Number	Pressure Rating		Oil Displacement per Stroke		Max. Operating Force (lbs)	Piston Stroke (in)	Oil Outlet Port	Weight (lbs)
				1st Stage (psi)	2nd Stage (psi)	1st Stage (in ³)	2nd Stage (in ³)				
Single Acting	Two Speed	21.4	P350	200	10,000	0.18	0.05	88	0.38	¼"-18NPTF	6.6
		61.0	P1000	200	10,000	0.81	0.14	99	0.82	¾"-18NPTF	13.7

Model Number	Dimensions (in)									
	A	B	C	D	E	F	G	H	J	K
P350	13.43	5.91	13.89	9.09	2.36	1.34	14.13	3.35	2.56	-
P1000	21.77	6.34	23.03	14.96	3.59	1.26	19.96	4.88	3.94	16.93

TWO SPEED METAL HAND PUMPS

- All metal reservoirs resist cracks and leaks
- Two speed operation increases productivity and reduces user fatigue
- Internal pressure relief valve for over load protection
- Load release valve for single acting cylinder usage
- Large oil capacity to power a wide range of cylinders and tools

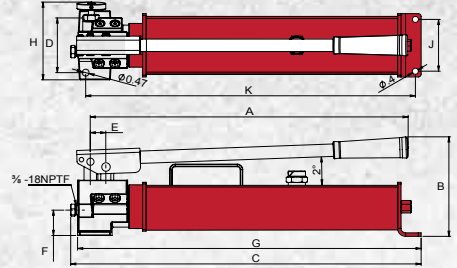

P2301

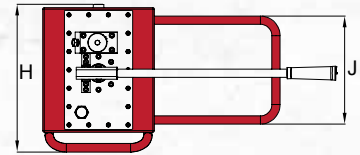

P8701

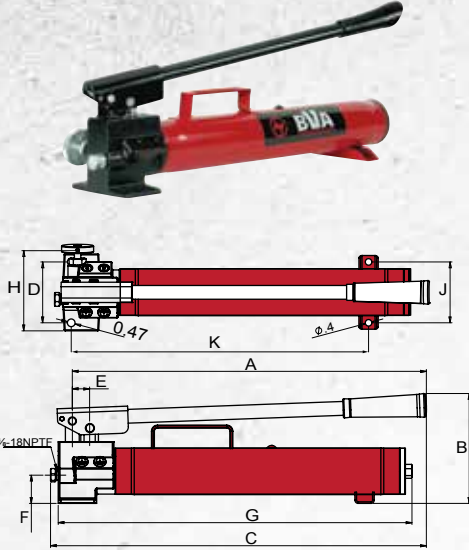

P1201

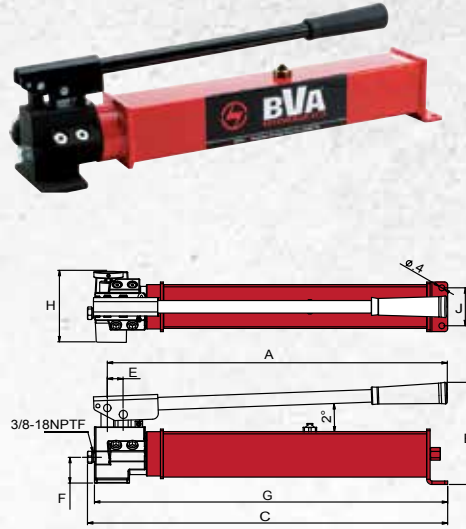

P2001

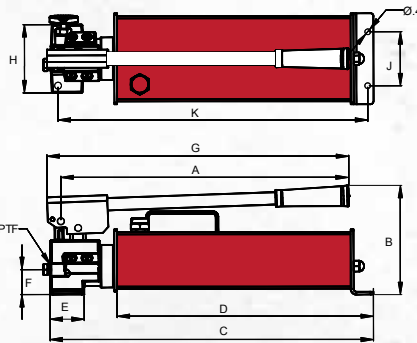

P4301



Used with Cylinder	Pump Type	Usable Oil Capacity (in ³)	Model Number	Pressure Rating		Oil Displacement per Stroke		Max. Operating Force (lbs)	Piston Stroke (in)	Oil Outlet Port	Weight (lbs)
				1st Stage (psi)	2nd Stage (psi)	1st Stage (in ³)	2nd Stage (in ³)				
Single Acting	Two Speed	67.0	P1201	200	10,000	0.81	0.14	99	0.82	3/8"-18NPTF	20.5
		122.0	P2001	200	10,000	0.81	0.14	95	0.82	3/8"-18NPTF	24.2
		128.0	P2301	200	10,000	0.81	0.14	99	0.82	3/8"-18NPTF	27.7
		250.0	P4301	200	10,000	0.81	0.14	99	0.82	3/8"-18NPTF	37.6
		476.0	P8701	290	10,000	7.71	0.29	143	1.69	3/8"-18NPTF	76.0

Model Number	Dimensions (in)										
	A	B	C	D	E	F	G	H	J	K	
P1201	21.73	6.73	23.07	3.74	1.06	1.73	21.73	4.92	3.74	18.27	
P2001	22.91	6.89	24.29	-	1.06	1.73	23.82	4.80	2.56	-	
P2301	21.73	6.81	23.98	3.74	1.06	1.73	23.50	5.31	3.54	22.56	
P4301	21.73	7.68	22.87	3.74	1.06	1.73	22.40	5.31	3.74	21.46	
P8701	25.79	11.61	30.35	11.54	24.17	8.25	26.94	15.24	11.18	-	

DOUBLE ACTING HAND PUMPS

- 4-way control valve for operation of double acting cylinders
- Large oil capacities to power a wide range of cylinders and tools
- Two speed operation increases productivity and reduces user fatigue

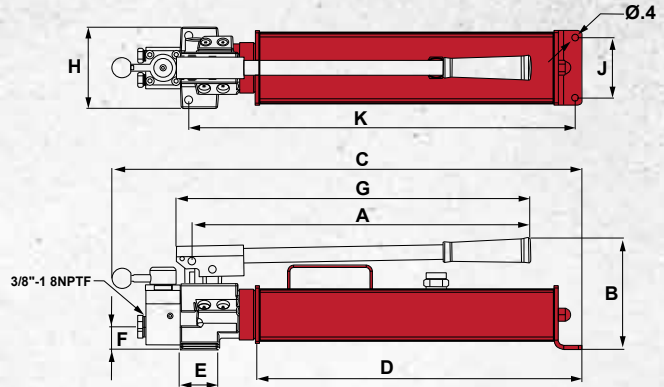

P2301M

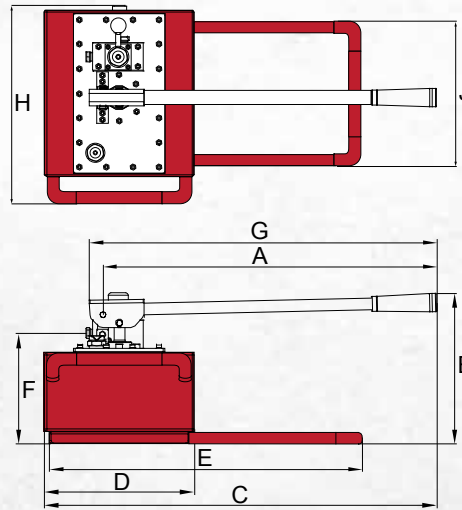

P8701M

Used with Cylinder	Pump Type	Usable Oil Capacity (in ³)	Model Number	Pressure Rating		Oil Displacement per Stroke		Max. Operating Force (lbs)	Piston Stroke (in)	Oil Outlet Port	Weight (lbs)
				1st Stage (psi)	2nd Stage (psi)	1st Stage (in ³)	2nd Stage (in ³)				
Double Acting	Two Speed	128.0	P2301M	200	10,000	0.81	0.14	99	0.82	3/8"-18NPTF	32.3
		476.0	P8701M	290	10,000	7.31	0.29	143	1.67	3/8"-18NPTF	77.4

Model Number	Dimensions (in)									
	A	B	C	D	E	F	G	H	J	K
P2301M	25.45	6.81	27.44	3.74	1.06	25.93	21.73	4.72	3.54	22.56
P8701M	25.79	11.61	30.35	11.54	24.17	8.25	26.94	15.24	11.18	-

ELECTRIC PUMPS

- Quiet operation meets OSHA regulations (80dBA)
- 2 speed operation allows for faster cylinder advance
- Full load starting capacities
- Internal filter keeps contamination from damaging pump
- Rugged durable design meets the demands of industrial applications
- Precision components to minimize wear and improve overall dependability
- 50 Hertz motors optional

*Positive locking valve available please refer to page 42

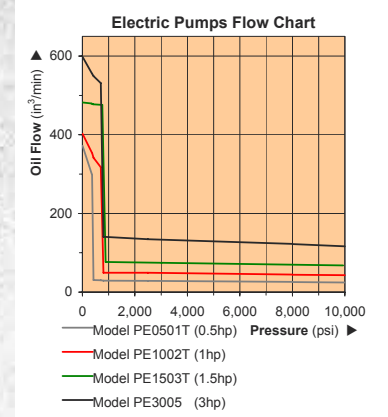

Use with Cylinder	Motor Size (hp)	Usable Oil Capacity (gal)	Model Number	Pressure Rating		Oil Output Flow Rate		Valve Type	Valve Function	Current Draw (amps)	Motor Voltage (volts)	Weight (lbs)
				1st Stage (psi)	2nd Stage (psi)	1st Stage (in ³ /min)	2nd Stage (in ³ /min)					
Single Acting	0.5	1.0	PE0501T	350	10,000	293	18	3-way, 3-position	Advance/ Hold/ Return	9	115	59.5
	1.0	2.0	PE1002T	700	10,000	397	37			12	115	70.5
	1.5	3.0	PE1503T	700	10,000	476	61			17	115	88.5
	1.5	5.0	PE1505T	700	10,000	476	61			17	115	94.0
	1.5	10.0	PE1510T	700	10,000	476	61			17	115	116.0
	1.5	15.0	PE1515T	700	10,000	476	61			17	115	127.0
	1.5	25.0	PE1525T	700	10,000	476	61			17	115	148.0
	3.0	5.0	PE3005T	700	10,000	592	110			17	230	101.0
	3.0	10.0	PE3010T	700	10,000	592	110			17	230	123.0
	3.0	15.0	PE3015T	700	10,000	592	110			17	230	134.0
Double Acting	0.5	1.0	PEM0501T	350	10,000	293	18	4-way, 3-position	Advance/ Hold/ Return	9	115	59.5
	1.0	2.0	PEM1002T	700	10,000	397	37			12	115	70.5
	1.5	3.0	PEM1503T	700	10,000	476	61			17	115	88.5
	1.5	5.0	PEM1505T	700	10,000	476	61			17	115	94.0
	1.5	10.0	PEM1510T	700	10,000	476	61			17	115	116.0
	1.5	15.0	PEM1515T	700	10,000	476	61			17	115	127.0
	1.5	25.0	PEM1525T	700	10,000	476	61			17	115	148.0
	3.0	5.0	PEM3005T	700	10,000	592	110			17	230	101.0
	3.0	10.0	PEM3010T	700	10,000	592	110			17	230	123.0
	3.0	15.0	PEM3015T	700	10,000	592	110			17	230	134.0
3.0	25.0	PEM3025T	700	10,000	592	110	17	230	155.0			

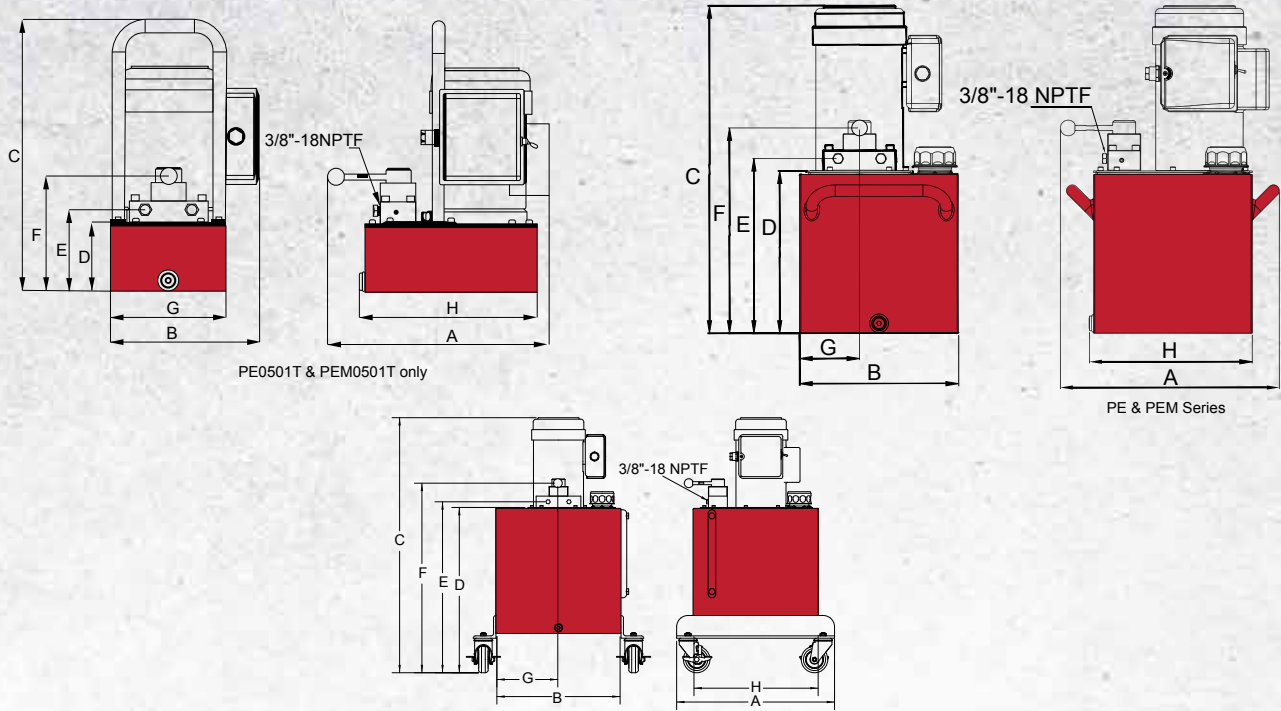

Model Number	Dimensions (in)							
	A	B	C	D	E	F	G	H
PE0501T	14.92	10.28	19.09	4.72	5.67	7.99	8.07	12.36
PE1002T	16.65	12.01	17.83	5.94	6.89	9.21	4.53	12.36
PE1503T	16.65	12.01	19.72	7.24	8.19	10.51	4.53	12.36
PE1505T	16.57	12.01	24.78	12.28	13.21	15.53	4.53	12.32
PE1510T	20.87	16.54	31.48	18.98	19.93	22.25	8.27	16.54
PE1515T	20.87	16.54	34.63	22.13	23.08	25.40	8.27	16.54
PE1525T/	25.59	21.26	34.63	22.13	23.08	25.40	10.63	21.26
PE3005T	16.54	12.01	26.54	12.28	13.23	15.51	4.53	12.36
PE3010T	20.87	16.54	33.24	18.98	19.93	22.25	8.27	16.54
PE3015T	20.87	16.54	36.39	22.13	23.08	25.40	8.27	16.54
PE3025T	25.59	21.26	36.39	22.13	23.08	25.40	10.63	21.26
PEM0501T	14.92	10.28	19.09	4.72	5.67	7.99	8.07	12.36
PEM1002T	16.65	12.01	17.83	5.94	6.89	9.21	4.53	12.36
PEM1503T	16.65	12.01	19.72	7.24	8.19	10.51	4.53	12.36
PEM1505T	16.57	12.01	24.78	12.28	13.21	15.53	4.53	12.32
PEM1510T	20.87	16.54	31.48	18.98	19.93	22.25	8.27	16.54
PEM1515T	20.87	16.54	34.63	22.13	23.08	25.40	8.27	16.54
PEM1525T	25.59	21.26	34.63	22.13	23.08	25.40	10.63	21.26
PEM3005T	16.54	12.01	26.54	12.28	13.23	15.51	4.53	12.36
PEM3010T	20.87	16.54	33.24	18.98	19.93	22.25	8.27	16.54
PEM3015T	20.87	16.54	36.39	22.13	23.08	25.40	8.27	16.54
PEM3025T	25.59	21.26	36.39	22.13	23.08	25.40	10.63	21.26

ELECTRIC PUMPS with LOCKING MANUAL VALVE

- Quiet operations meets OSHA regulations (80 dBA)
- 2 speed operation allows for faster cylinder advance
- Locking plate for positive load holding
- Internal filter keeps contamination from damaging the pump
- Precision components to minimize wear and improve overall dependability
- All pumps on this page are single phase electric motors
- 50 Hertz motors optional

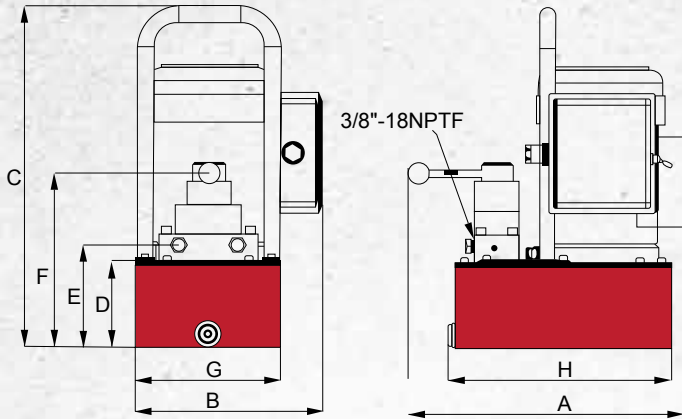

Use with Cylinders	Motor Size (hp)	Usable Oil Capacity (gal)	Model Number	Pressure Rating		Oil Output Flow Rate		Valve Type	Valve Function	Current Draw (amps)	Motor Voltage (volts)	Weight (lbs)
				1st Stage (psi)	2nd Stage (psi)	1st Stage (in ³ /min)	2nd Stage (in ³ /min)					
Single Acting	0.5	1	PEL0501T	350	10,000	293	18	3-way, 3-position	Advance/ Hold/ Return	9	115	65.9
	0.5	2	PEL0502T	350	10,000	293	18			9	115	65.9
	1.0	2	PEL1002T	700	10,000	311	37			12	115	69.7
	1.5	3	PEL1503T	700	10,000	476	61			17	115	77
	1.5	5	PEL1505T	700	10,000	476	61			17	115	94.8
	1.5	10	PEL1510T	700	10,000	476	61			17	115	102.4
	1.5	15	PEL1515T	700	10,000	476	61			17	115	122.4
	1.5	25	PEL1525T	700	10,000	476	61			17	115	133.4
	3.0	5	PEL3005T	700	10,000	592	110			17	230	154.4
	3.0	10	PEL3010T	700	10,000	592	110			17	230	129.4
	3.0	15	PEL3015T	700	10,000	592	110			17	230	140.4
Double Acting	3.0	25	PEL3025T	700	10,000	592	110	17	230	161.4		
	0.5	1	PEML0501T	700	10,000	293	18	4-way, 3-position	Advance/ Hold/ Return	9	115	65.9
	0.5	2	PEML0502T	700	10,000	293	18			9	115	65.9
	1.0	2	PEML1002T	700	10,000	311	37			12	115	69.7
	1.5	3	PEML1503T	700	10,000	476	61			17	115	77
	1.5	5	PEML1505T	700	10,000	476	61			17	115	94.8
	1.5	10	PEML1510T	700	10,000	476	61			17	115	102.4
	1.5	15	PEML1515T	700	10,000	476	61			17	115	122.4
	1.5	25	PEML1525T	700	10,000	476	61			17	115	133.4
	3.0	5	PEML3005T	700	10,000	592	110			17	230	154.4
	3.0	10	PEML3010T	700	10,000	592	110			17	230	129.4
	3.0	15	PEML3015T	700	10,000	592	110			17	230	140.4
	3.0	25	PEML3025T	700	10,000	592	110			17	230	161.4

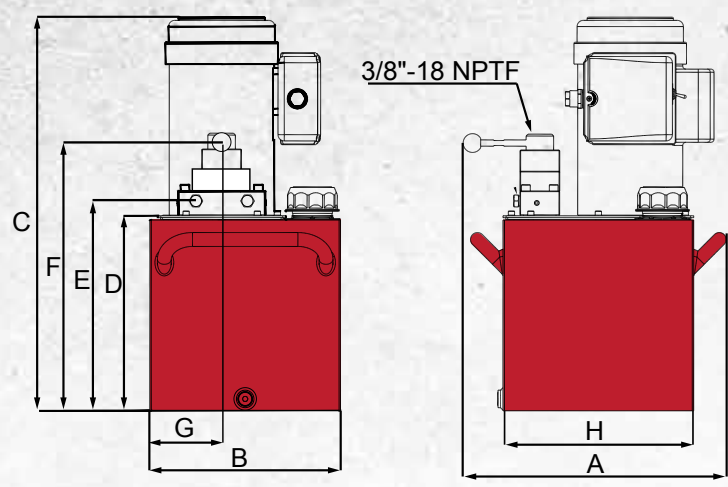

Model Number	Dimensions (in)							
	A	B	C	D	E	F	G	H
PEL0501T	14.92	10.28	19.09	4.72	5.67	7.43	8.07	12.36
PEL0502T	17.33	12.01	20.36	5.78	6.89	14.92	4.51	12.36
PEL1002T	16.65	12.01	17.83	5.94	6.89	8.65	4.53	12.36
PEL1503T	16.65	12.01	19.72	7.24	8.19	9.95	4.53	12.36
PEL1505T	16.57	12.01	24.78	12.28	13.21	14.97	4.53	12.36
PEL1510T	20.87	16.54	31.48	18.98	19.93	21.69	8.27	16.54
PEL1515T	20.87	16.54	34.63	22.13	23.08	24.84	8.27	16.54
PEL1525T	25.59	21.26	34.63	22.13	23.08	24.84	10.63	21.26
PEL3005T	16.54	12.01	26.54	12.28	13.25	15.01	4.53	12.36
PEL3010T	20.87	16.54	33.24	18.98	19.93	21.69	8.27	16.54
PEL3015T	20.87	16.54	36.39	22.13	23.08	24.84	8.27	16.54
PEL3025T	25.59	21.26	36.39	22.13	23.08	24.84	10.63	21.26
PEML0501T	14.92	10.28	19.09	4.72	5.67	7.43	8.07	12.36
PEML0502T	0.00	0.00	0.00	0.00	0.00	1.76	0.00	0.00
PEML1002T	16.65	12.01	34.63	5.94	6.89	8.65	4.53	12.36
PEML1503T	16.65	12.01	34.63	7.24	8.19	9.95	4.53	12.36
PEML1505T	16.57	12.01	26.54	12.28	13.21	14.97	4.53	12.36
PEML1510T	20.87	16.54	33.24	18.98	19.93	21.69	8.27	16.54
PEML1515T	20.87	16.54	36.39	22.13	23.08	24.84	8.27	16.54
PEML1525T	25.59	21.26	36.39	22.13	23.08	24.84	10.63	21.26
PEML3005T	16.54	12.01	26.54	12.28	13.25	15.01	4.53	12.36
PEML3010T	20.87	16.54	33.24	18.98	19.93	21.69	8.27	16.54
PEML3015T	20.87	16.54	36.39	22.13	23.08	24.84	8.27	16.54
PEML3025T	25.59	21.26	36.39	22.13	23.08	24.84	10.63	21.26

ELECTRIC PUMPS with PENDANT SWITCH

- Quiet operation meets OSHA regulations (80dBA)
- 2 speed operation allows for faster cylinder advance
- Full load starting capacities
- Internal filter keeps contamination from damaging pump
- 10 ft. hand held pendant switch allows user to turn on/off motor
- All pumps are single phase
- Pumps come with manual valve
- Toggle switch only turns on/off motor
- 50 Hertz motors optional



Electric pumps can be used in a variety of industrial settings



Use with Cylinder	Motor Size (hp)	Usable Oil Capacity (gal)	Model Number	Pressure Rating		Oil Output Flow Rate		Valve Type	Valve Function	Current Draw (amps)	Motor Voltage (volts)	Weight (lbs)
				1st Stage (psi)	2nd Stage (psi)	1st Stage (in ³ /min)	2nd Stage (in ³ /min)					
Single Acting	0.5	1.0	PEW0501T	350	10,000	293	18	3-way, 3-position	Advance/ Hold/ Return	9	115	59.5
	1.0	2.0	PEW1002T	700	10,000	397	37			12	115	70.5
	1.5	3.0	PEW1503T	700	10,000	476	61			17	115	88.5
	1.5	5.0	PEW1505T	700	10,000	476	61			17	115	94.0
	1.5	10.0	PEW1510T	700	10,000	476	61			17	115	116.0
	1.5	15.0	PEW1515T	700	10,000	476	61			17	115	127.0
	1.5	25.0	PEW1525T	700	10,000	476	61			17	115	148.0
	3.0	5.0	PEW3005T	700	10,000	592	110			17	230	101.0
	3.0	10.0	PEW3010T	700	10,000	592	110			17	230	123.0
	3.0	15.0	PEW3015T	700	10,000	592	110			17	230	134.0
Double Acting	3.0	25.0	PEW3025T	700	10,000	592	110	4-way, 3-position	Advance/ Hold/ Return	17	230	155.0
	0.5	1.0	PEWM0501T	350	10,000	293	18			9	115	59.5
	1.0	2.0	PEWM1002T	700	10,000	397	37			12	115	70.5
	1.5	3.0	PEWM1503T	700	10,000	476	61			17	115	88.5
	1.5	5.0	PEWM1505T	700	10,000	476	61			17	115	94.0
	1.5	10.0	PEWM1510T	700	10,000	476	61			17	115	116.0
	1.5	15.0	PEWM1515T	700	10,000	476	61			17	115	127.0
	1.5	25.0	PEWM1525T	700	10,000	476	61			17	115	148.0
	3.0	5.0	PEWM3005T	700	10,000	592	110			17	230	101.0
	3.0	10.0	PEWM3010T	700	10,000	592	110			17	230	123.0
3.0	15.0	PEWM3015T	700	10,000	592	110	17	230	134.0			
3.0	25.0	PEWM3025T	700	10,000	592	110	17	230	155.0			

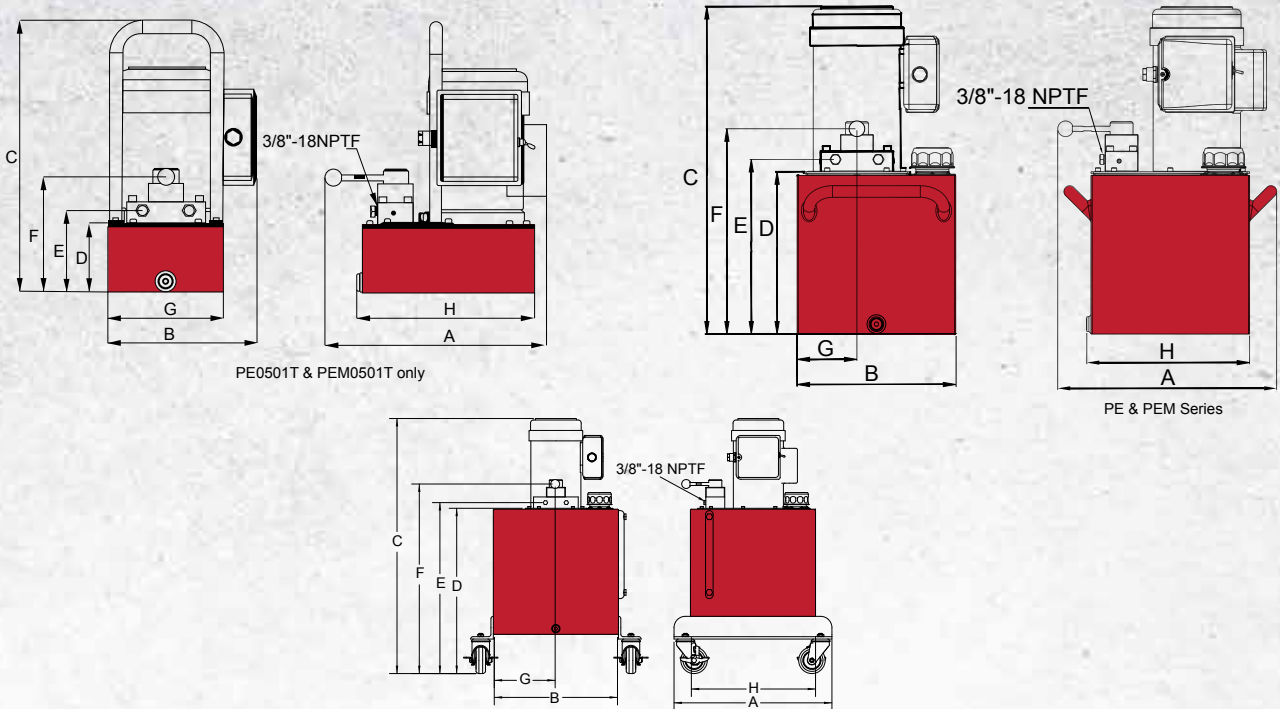

Model Number	Dimensions (in)							
	A	B	C	D	E	F	G	H
PEW0501T	14.92	10.28	19.09	4.72	5.67	7.99	8.07	12.36
PEW1002T	16.65	12.01	17.83	5.94	6.89	9.21	4.53	12.36
PEW1503T	16.65	12.01	19.72	7.24	8.19	10.51	4.53	12.36
PEW1505T	16.57	12.01	24.78	12.28	13.21	15.53	4.53	12.32
PEW1510T	20.87	16.54	31.48	18.98	19.93	22.25	8.27	16.54
PEW1515T	20.87	16.54	34.63	22.13	23.08	25.40	8.27	16.54
PEW1525T	25.59	21.26	34.63	22.13	23.08	25.40	10.63	21.26
PEW3005T	16.54	12.01	26.54	12.28	13.23	15.51	4.53	12.36
PEW3010T	20.87	16.54	33.24	18.98	19.93	22.25	8.27	16.54
PEW3015T	20.87	16.54	36.39	22.13	23.08	25.40	8.27	16.54
PEW3025T	25.59	21.26	36.39	22.13	23.08	25.40	10.63	21.26
PEWM0501T	14.92	10.28	19.09	4.72	5.67	7.99	8.07	12.36
PEWM1002T	16.65	12.01	17.83	5.94	6.89	9.21	4.53	12.36
PEWM1503T	16.65	12.01	19.72	7.24	8.19	10.51	4.53	12.36
PEWM1505T	16.57	12.01	24.78	12.28	13.21	15.53	4.53	12.32
PEWM1510T	20.87	16.54	31.48	18.98	19.93	22.25	8.27	16.54
PEWM1515T	20.87	16.54	34.63	22.13	23.08	25.40	8.27	16.54
PEWM1525T	25.59	21.26	34.63	22.13	23.08	25.40	10.63	21.26
PEWM3005T	16.54	12.01	26.54	12.28	13.23	15.51	4.53	12.36
PEWM3010T	20.87	16.54	33.24	18.98	19.93	22.25	8.27	16.54
PEWM3015T	20.87	16.54	36.39	22.13	23.08	25.40	8.27	16.54
PEWM3025T	25.59	21.26	36.39	22.13	23.08	25.40	10.63	21.26

ELECTRIC PUMPS with LOCKING MANUAL VALVE and PENDANT SWITCH

- Quiet operation meets OSHA regulations (80 dBA)
- 2 speed operation allows for faster cylinder advance
- Full load starting capacities
- Internal filter keeps contamination from damaging the pump
- Precision components to minimize wear and improve overall dependability
- All pumps on this page are single phase electric motors
- 10 foot hand held pendant switch allows user to turn the motor on/off
- 50 Hertz motors optional



Use with Cylinders	Motor Size (hp)	Usable Oil Capacity (gal)	Model Number	Pressure Rating		Oil Output Flow Rate		Valve Type	Valve Function	Current Draw (amps)	Motor Voltage (volts)	Weight (lbs)
				1st Stage (psi)	2nd Stage (psi)	1st Stage (in ³ /min)	2nd Stage (in ³ /min)					
Single Acting	0.5	1	PEWL0501T	350	10,000	293	18	3-way, 3-position	Advance/ Hold/ Return	9	115	65.9
	0.5	2	PEWL0502T	350	10,000	293	18			9	115	65.9
	1.0	2	PEWL1002T	700	10,000	311	37			12	115	69.7
	1.5	3	PEWL1503T	700	10,000	476	61			17	115	77
	1.5	5	PEWL1505T	700	10,000	476	61			17	115	94.8
	1.5	10	PEWL1510T	700	10,000	476	61			17	115	102.4
	1.5	15	PEWL1515T	700	10,000	476	61			17	115	122.4
	1.5	25	PEWL1525T	700	10,000	476	61			17	115	133.4
	3.0	5	PEWL3005T	700	10,000	592	110			17	230	154.4
	3.0	10	PEWL3010T	700	10,000	592	110			17	230	129.4
	3.0	15	PEWL3015T	700	10,000	592	110			17	230	140.4
Double Acting	3.0	25	PEWL3025T	700	10,000	592	110	4-way, 3-position	Advance/ Hold/ Return	17	230	161.4
	0.5	1	PEWML0501T	700	10,000	293	18			9	115	65.9
	0.5	2	PEWML0502T	700	10,000	293	18			9	115	65.9
	1.0	2	PEWML1002T	700	10,000	311	37			12	115	69.7
	1.5	3	PEWML1503T	700	10,000	476	61			17	115	77
	1.5	5	PEWML1505T	700	10,000	476	61			17	115	94.8
	1.5	10	PEWML1510T	700	10,000	476	61			17	115	102.4
	1.5	15	PEWML1515T	700	10,000	476	61			17	115	122.4
	1.5	25	PEWML1525T	700	10,000	476	61			17	115	133.4
	3.0	5	PEWML3005T	700	10,000	592	110			17	230	154.4
	3.0	10	PEWML3010T	700	10,000	592	110			17	230	129.4
	3.0	15	PEWML3015T	700	10,000	592	110			17	230	140.4
	3.0	25	PEWML3025T	700	10,000	592	110			17	230	161.4

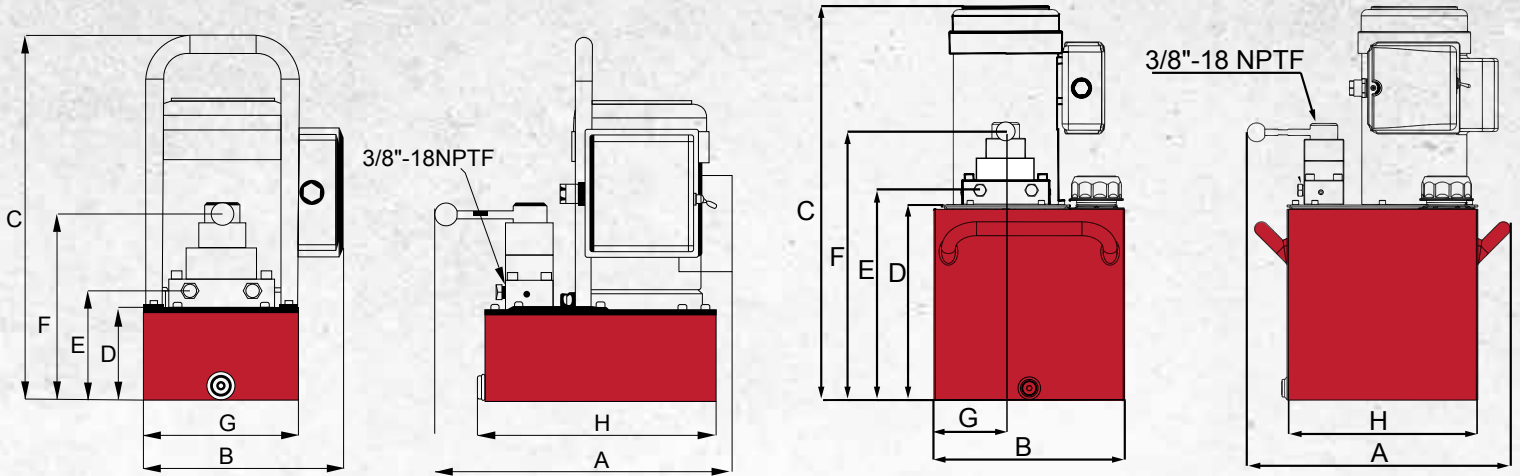

Model Number	Dimensions (in)							
	A	B	C	D	E	F	G	H
PEWL0501T	14.92	10.28	19.09	4.72	5.67	7.43	8.07	12.36
PEWL0502T	17.88	12.01	20.36	5.93	6.89	14.92	4.51	12.36
PEWL1002T	16.65	12.01	17.83	5.94	6.89	8.65	4.53	12.36
PEWL1503T	16.65	12.01	19.72	7.24	8.19	9.95	4.53	12.36
PEWL1505T	16.57	12.01	24.78	12.28	13.21	14.97	4.53	12.36
PEWL1510T	20.87	16.54	31.48	18.98	19.93	21.69	8.27	16.54
PEWL1515T	20.87	16.554	34.63	22.13	23.08	24.84	8.27	16.54
PEWL1525T	25.59	21.26	34.63	22.13	23.08	24.84	10.63	21.26
PEWL3005T	16.54	12.01	26.54	12.28	13.25	15.01	4.53	12.36
PEWL3010T	20.87	16.54	33.24	18.98	19.93	21.69	8.27	16.54
PEWL3015T	20.87	16.54	36.39	22.13	23.08	24.84	8.27	16.54
PEWL3025T	25.59	21.26	36.39	22.13	23.08	24.84	10.63	21.26
PEWML0501T	14.92	10.28	19.09	4.72	5.67	7.43	8.07	12.36
PEWML0502T	0.00	0.00	0.00	0.00	0.00	1.76	0.00	0.00
PEWML1002T	16.65	12.01	34.63	5.94	6.89	8.65	4.53	12.36
PEWML1503T	16.65	12.01	34.63	7.24	8.19	9.95	4.53	12.36
PEWML1505T	16.57	12.01	26.54	12.28	13.21	14.97	4.53	12.36
PEWML1510T	20.87	16.54	33.24	18.98	19.93	21.69	8.27	16.54
PEWML1515T	20.87	16.554	36.39	22.13	23.08	24.84	8.27	16.54
PEWML1525T	25.59	21.26	36.39	22.13	23.08	24.84	10.63	21.26
PEWML3005T	16.54	12.01	26.54	12.28	13.25	15.01	4.53	12.36
PEWML3010T	20.87	16.54	33.24	18.98	19.93	21.69	8.27	16.54
PEWML3015T	20.87	16.54	36.39	22.13	23.08	24.84	8.27	16.54
PEWML3025T	25.59	21.26	36.39	22.13	23.08	24.84	10.63	21.26

ELECTRIC PUMPS with LOCKING SOLENOID VALVE

- Locking valve provides positive load holding
- Quiet operation meets OSHA regulations (80dBA)
- Ideal for applications where a remote control is required
- 2 speed operation allows for faster cylinder advance
- Full load starting capabilities
- Internal filter keeps contamination from damaging pump
- 10 ft. hand held remote controls the solenoid valve
- Wireless hand held remote option is available
- 50 Hertz motors optional



Use with Cylinder	Motor Size (hp)	Usable Oil Capacity (gal)	Model Number	Pressure Rating		Oil Output Flow Rate		Valve Type	Valve Function	Current Draw (amps)	Motor Voltage (volts)	Weight (lbs)
				1st Stage (psi)	2nd Stage (psi)	1st Stage (in ³ /min)	2nd Stage (in ³ /min)					
Single Acting	0.5	1.0	PESL0501T	350	10,000	293	18	3-Way, 3-Position	Advance/ Hold/ Return	9	115	61.5
	0.5	2.0	PESL0502T	700	10,000	293	18			9	115	65.3
	1.0	2.0	PESL1002T	700	10,000	311	37			12	115	72.6
	1.5	3.0	PESL1503T	700	10,000	476	61			17	115	90.4
	1.5	5.0	PESL1505T	700	10,000	476	61			17	115	98.0
	1.5	10.0	PESL1510T	700	10,000	476	61			17	115	118.0
	1.5	15.0	PESL1515T	700	10,000	476	61			17	115	129.0
	1.5	25.0	PESL1525T	700	10,000	592	110			17	230	150.0
	3.0	5.0	PESL3005T	700	10,000	592	110			17	230	101.0
	3.0	10.0	PESL3010T	700	10,000	592	110			17	230	125.0
	3.0	15.0	PESL3015T	700	10,000	592	110			17	230	136.0
	3.0	25.0	PESL3025T	700	10,000	592	110			17	230	157.0
Double Acting	0.5	1.0	PESML0501T	350	10,000	293	18	4-Way, 3-Position	Advance/ Hold/ Return	9	115	61.5
	0.5	2.0	PESML0502T	700	10,000	293	18			9	115	65.3
	1.0	2.0	PESML1002T	700	10,000	311	37			12	115	72.6
	1.5	3.0	PESML1503T	700	10,000	476	61			17	115	90.4
	1.5	5.0	PESML1505T	700	10,000	476	61			17	115	98.0
	1.5	10.0	PESML1510T	700	10,000	476	61			17	115	118.0
	1.5	15.0	PESML1515T	700	10,000	476	61			17	115	129.0
	1.5	25.0	PESML1525T	700	10,000	592	110			17	230	150.0
	3.0	5.0	PESML3005T	700	10,000	592	110			17	230	101.0
	3.0	10.0	PESML3010T	700	10,000	592	110			17	230	125.0
	3.0	15.0	PESML3015T	700	10,000	592	110			17	230	136.0
	3.0	25.0	PESML3025T	700	10,000	592	110			17	230	157.0

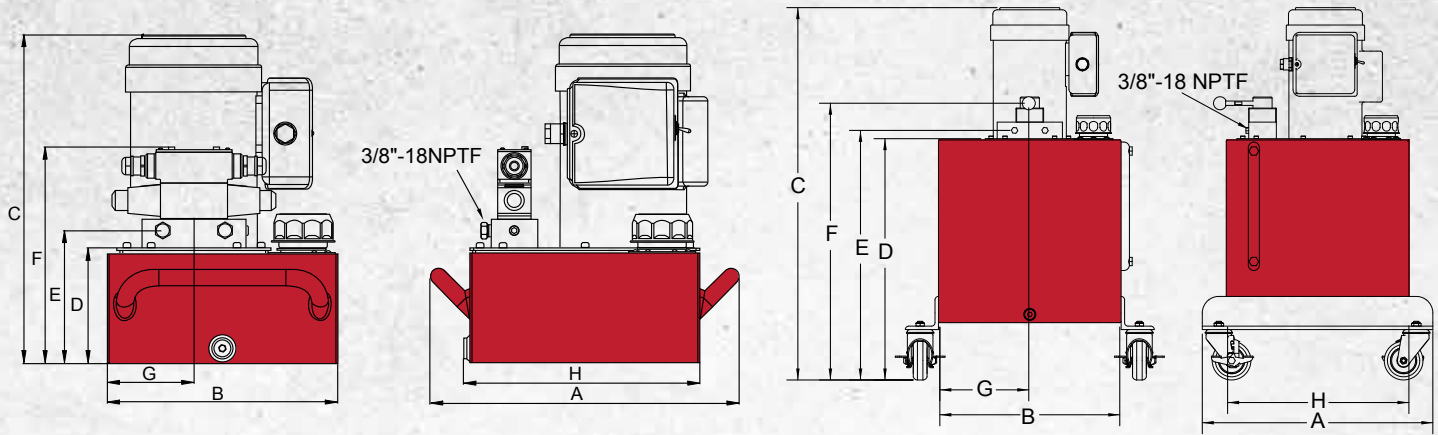

Model Number	Dimensions (in)							
	A	B	C	D	E	F	G	H
PESL0501T	12.74	10.26	19.10	4.72	5.65	11.96	8.07	12.36
PESL0502T	17.88	12.01	20.36	5.94	6.89	13.18	4.51	12.36
PESL1002T	17.88	12.01	17.88	5.94	6.89	13.18	4.51	12.36
PESL1503T	17.88	12.01	17.88	7.24	8.19	14.48	4.51	12.36
PESL1505T	16.10	12.01	17.13	12.28	13.23	19.52	4.51	12.36
PESL1510T	20.87	16.54	31.48	18.98	19.89	26.38	8.27	16.54
PESL1515T	20.87	16.54	34.63	22.13	23.04	29.53	8.27	16.54
PESL1525T	25.59	21.26	34.63	22.13	23.04	29.53	10.63	21.26
PESL3005T	16.54	12.01	26.54	12.28	13.23	15.51	4.53	12.36
PESL3010T	20.87	16.54	33.24	18.98	19.89	26.38	8.27	16.54
PESL3015T	20.87	16.54	36.39	22.13	23.04	29.53	8.27	16.54
PESL3025T	25.59	21.26	36.39	22.13	23.04	29.53	10.63	21.26
PESML0501T	12.74	10.26	19.10	4.72	5.65	11.96	8.07	12.36
PESML0502T	12.74	10.26	19.10	4.72	5.65	11.96	8.07	12.36
PESML1002T	17.88	12.01	17.88	5.98	6.90	13.16	4.51	12.36
PESML1503T	17.88	12.01	17.88	5.98	6.90	13.16	4.51	12.32
PESML1505T	16.10	12.01	17.13	5.98	6.90	13.16	4.51	12.36
PESML1510T	20.87	16.54	31.48	18.98	19.89	26.38	8.27	16.54
PESML1515T	20.87	16.54	34.63	22.13	23.04	29.53	8.27	16.54
PESML1525T	25.59	21.26	34.63	22.13	23.04	29.53	10.63	21.26
PESL3005T	16.54	12.01	26.54	12.28	13.23	15.51	4.53	12.36
PESML3010T	20.87	16.54	33.24	18.98	19.89	26.38	8.27	16.54
PESML3015T	20.87	16.54	36.39	22.13	23.04	29.53	8.27	16.54
PESML3025T	25.59	21.26	36.39	22.13	23.04	29.53	10.63	21.26

ELECTRIC PUMPS with AUTO RETURN VALVE

- Quiet operation meets OSHA regulations (80dBA)
- Best suited for punching, crimping, and cutting applications
- 2 speed operation allows for faster cylinder advance
- Full load starting capabilities
- Internal filter keeps contamination from damaging pump
- Rugged durable design meets the demands of industrial applications
- 10 ft. remote pendant switch to control motor on/of
- PED series includes 10' remote pendant motor on/off control
- PEDS series includes solenoid valve control

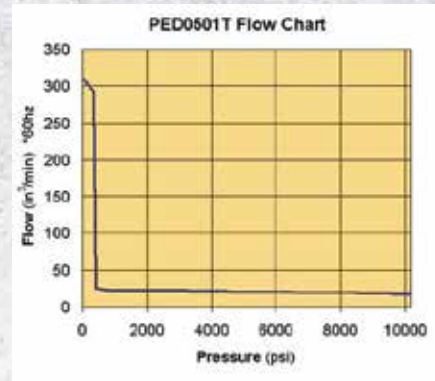

PED0501T



PEDS503T

Motor Size (hp)	Usable Oil Capacity (gal)	Model Number	Pressure Rating		Oil Output Flow Rate		Valve Type	Valve Function	Current Draw (amps)	Motor Voltage (volts)	Sound Level (dBA)	Weight (lbs)
			1st Stage (psi)	2nd Stage (psi)	1st Stage (in ³ /min)	2nd Stage (in ³ /min)						
0.5	1	PED0501T	350	10,000	293	18	2-Way, 2 Position	Advance/Return	9	115	80	61.5
0.5	1	PEDS0501T	350	10,000	293	18	3-Way, 2 Position	Advance/Return	9	115	80	61.5
0.5	2	PEDS0502T	350	10,000	293	18	3-Way, 2 Position	Advance/Return	9	115	80	61.5
1	2	PEDS1002T	700	10,000	397	37	3-Way, 2 Position	Advance/Return	12	115	80	72.6
1.5	3	PEDS1503T	700	10,000	476	61	3-Way, 2 Position	Advance/Return	17	115	80	90.4
1.5	5	PEDS1505T	700	10,000	476	61	3-Way, 2 Position	Advance/Return	17	115	80	98
1.5	10	PEDS1510T	700	10,000	476	61	3-Way, 2 Position	Advance/Return	17	115	80	118
1.5	15	PEDS1515T	700	10,000	476	61	3-Way, 2 Position	Advance/Return	17	115	80	129
1.5	25	PEDS1525T	700	10,000	476	61	3-Way, 2 Position	Advance/Return	17	115	80	150
3	5	PEDS3005T	700	10,000	592	110	3-Way, 2 Position	Advance/Return	17	230	80	105
3	10	PEDS3010T	700	10,000	592	110	3-Way, 2 Position	Advance/Return	17	230	80	125
3	15	PEDS3015T	700	10,000	592	110	3-Way, 2 Position	Advance/Return	17	230	80	136
3	25	PEDS3025T	700	10,000	592	110	3-Way, 2 Position	Advance/Return	17	230	80	157

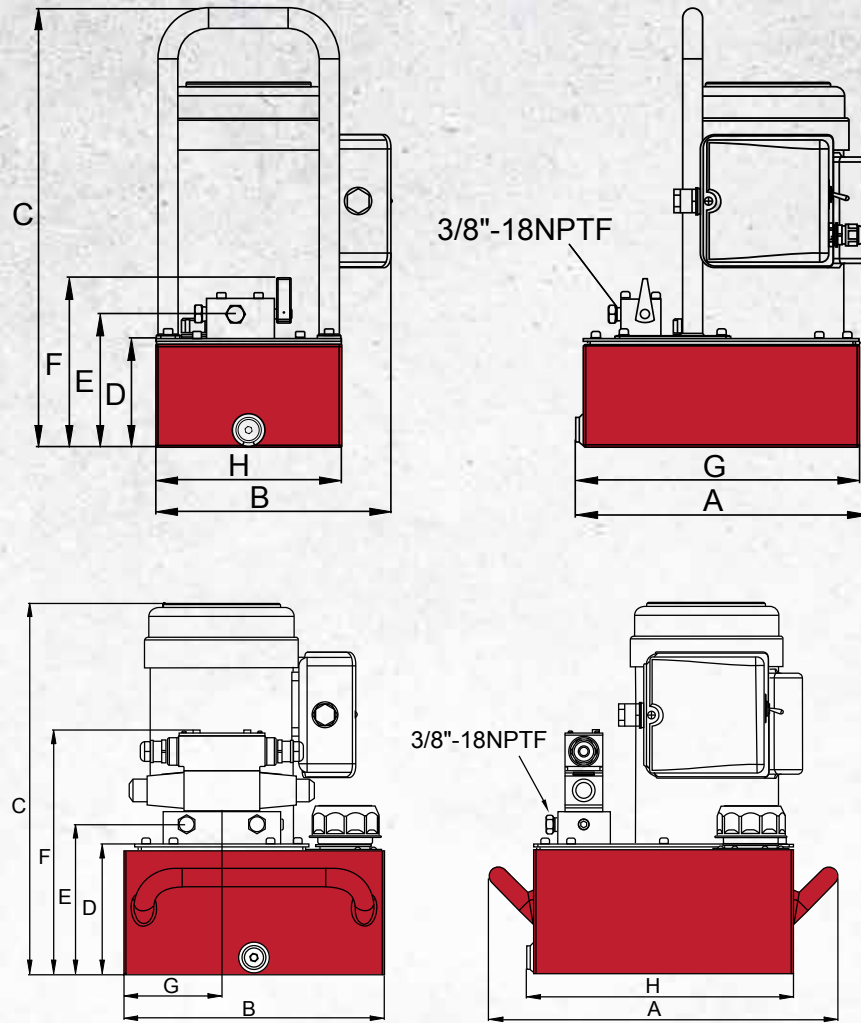

Model Number	Dimensions (in)							
	A	B	C	D	E	F	G	H
PED0501T	12.76	10.28	19.10	4.72	5.79	7.36	12.36	12.36
PEDS0501T	12.74	10.26	19.10	4.72	5.65	11.96	8.07	12.36
PEDS0502T	17.88	12.01	20.36	5.94	6.89	13.18	4.51	12.36
PEDS1002T	17.88	12.01	17.88	5.94	6.89	13.18	4.51	12.36
PEDS1503T	17.88	12.01	17.88	7.24	8.19	14.48	4.51	12.36
PEDS1505T	16.10	12.01	17.13	12.28	13.23	19.52	4.51	12.36
PEDS1510T	20.87	16.54	31.48	18.98	19.89	26.38	8.27	16.54
PEDS1515T	20.87	16.54	34.63	22.13	23.04	29.53	8.27	16.54
PEDS1525T	25.59	21.26	34.63	22.13	23.04	29.53	10.63	21.26
PEDS3005T	16.54	12.01	26.54	12.28	13.23	15.51	4.53	12.36
PEDS3010T	20.87	16.54	33.24	18.98	19.89	26.38	8.27	16.54
PEDS3015T	20.87	16.54	36.39	22.13	23.04	29.53	8.27	16.54
PEDS3025T	25.59	21.26	36.39	22.13	23.04	29.53	10.63	21.26

3 PHASE ELECTRIC MOTOR PUMPS

- Quiet operation meets OSHA regulations (80dba)
- 2 speed operation allows for faster cylinder advance
- Full load starting capacities
- Internal filter keeps contamination from damaging pump
- Rugged durable design meets the demands of industrial applications
- Precision components to minimize wear and improve overall dependability
- Motor can accept 50 Hz or 60 Hz electricity

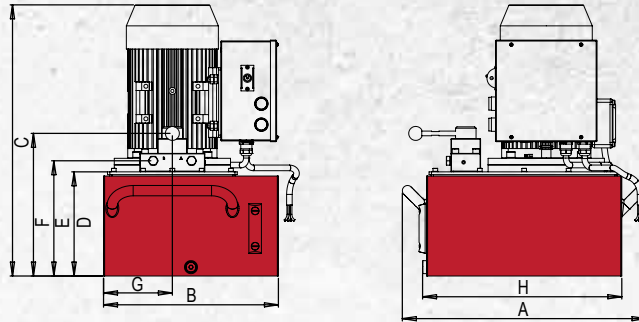

Model Number	Dimensions (in)							
	A	B	C	D	E	F	G	H
PE3006T-3	20.63	14.80	22.95	8.82	9.75	16.04	5.83	16.87
PESL3006T-3	20.63	14.80	22.95	8.82	9.75	16.04	5.83	16.87
PEM3006T-3	20.63	14.80	22.95	8.82	9.75	16.04	5.83	16.87
PESML3006T-3	20.63	14.80	22.95	8.82	9.75	16.04	5.83	16.87

Use with Cylinder	Motor Size (hp)	Electrical Supply (Phase)	Usable Oil Capacity (gal)	Model Number	Pressure Rating (psi)		Oil Output Flow Rate (in ³ /min)		Valve Type	Valve Function	Current Draw (amps)	Motor Voltage (volts)	Weight (lbs)
					1st Stage	2nd Stage	1st Stage	2nd Stage					
Single Acting	3.0	3	6	PE3006T-3	700	10,000	592	110	3-way, 3-position	Advance/ Hold/ Return	4-10	220 V 50-60 Hz	137
	3.0	3	6	PESL3006T-3	700	10,000	592	110					139
Double Acting	3.0	3	6	PEM3006T-3	700	10,000	592	110	4-way, 3-position	Advance/ Hold/ Return	4-10	220 V 50-60 Hz	137
	3.0	3	6	PESML3006T-3	700	10,000	592	110					139

GAS PUMP with HONDA ENGINE

- Gas engine pump will provide 10,000 psi. hydraulic force at remote locations
- Industrial grade 5.5 hp Honda gas engine
- Manual control valve for use with single or double acting cylinders or tools
- Two speed pump designed for rapid cylinder advance
- Gas pump features a sturdy protective roll cage for use in the toughest environments

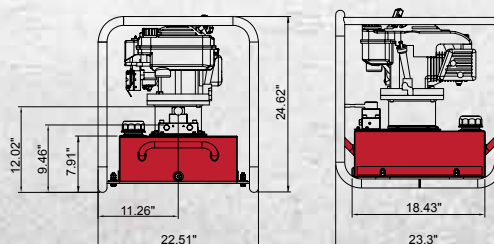

Motor Size (hp)	Usable Oil Capacity (gal)	Model Number	Max. Pressure Output (psi)	Pressure Rating (psi)		Oil Output Flow Rate (in ³ /min)		Valve Type	Valve Function	Rotation Speed (rpm)	Sound Level (dBA)	Weight (lbs)
				1st Stage	2nd Stage	1st Stage	2nd Stage					
5.5	5	PG5505	10,000	700	10,000	427	100	3 way, 3 position	Advance/ Hold/ Return	3,600	93	121.2
5.5	5	PGM5505	10,000	700	10,000	427	100	4 way, 3 position	Advance/ Hold/ Return	3,600	93	121.2

GAS PUMP with SOLENOID VALVE and HONDA ENGINE

- Gas engine pump will provide 10,000 psi. hydraulic force at remote locations
- Industrial grade 10.2 hp Honda gas engine
- Ideal for applications when a remote control is required
- Two speed pump designed for rapid cylinder advance
- Gas pump features a sturdy protective roll cage for use in the toughest environments

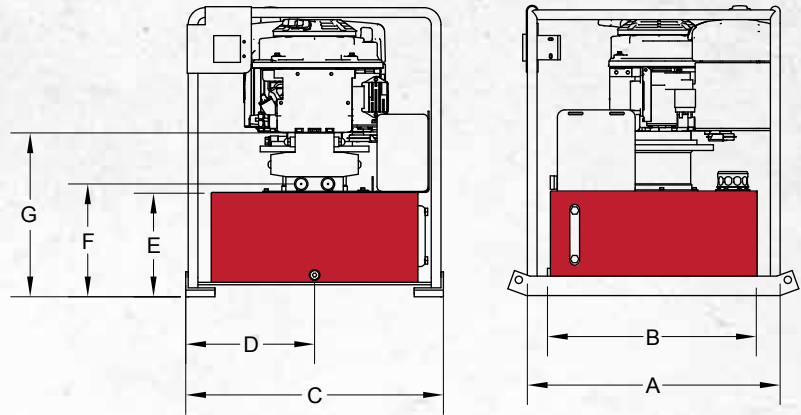

Motor Size (hp)	Usable Oil Capacity (gal)	Model Number	Max. Pressure Output (psi)	Pressure Rating (psi)		Valve Type	Valve Function	Rotation Speed (rpm)	Sound Level (dBA)	Weight (lbs)
				1st Stage	2nd Stage					
10.2	5	PGSL1005	10,000	700	10,000	3 way, 3 position	Advance/ Hold/ Return	3,600	93	194
10.2	5	PGSML1005	10,000	700	10,000	4 way, 3 position	Advance/ Hold/ Return	3,600	93	194
10.2	10	PGSL1010	10,000	700	10,000	3 way, 3 position	Advance/ Hold/ Return	3,600	93	223
10.2	10	PGSML1010	10,000	700	10,000	4 way, 3 position	Advance/ Hold/ Return	3,600	93	223
10.2	15	PGSL1015	10,000	700	10,000	3 way, 3 position	Advance/ Hold/ Return	3,600	93	252
10.2	15	PGSML1015	10,000	700	10,000	4 way, 3 position	Advance/ Hold/ Return	3,600	93	252

Oil Output Flow Rate	
PSI	In ³ /Min.
no load	1,070
1,000	592
5,000	256
10,000	200

Model Number	Dimensions (in)						
	A	B	C	D	E	F	G
PGSL1005	26.57	21.5	20.94	10.47	11.50	12.43	15.47
PGSML1005	26.57	21.5	20.94	10.47	11.50	12.43	18.74
PGSL1010	28.25	23.37	27	13.5	12	12.93	17.375
PGSML1010	28.5	23.37	27	13.5	12	12.93	19.765
PGSL1015	28.25	23.37	27	13.5	12	12.93	17.375
PGSML1015	28.25	23.37	27	13.5	12	12.93	19.765

DIESEL PUMP with SOLENOID VALVE AND HATZ ENGINE



- Pump will provide 10,000 psi. hydraulic force at remote locations
- Industrial grade 7.3 hp HATZ Diesel engine
- Locking solenoid control valve for use with single or double acting cylinders or tools
- 10 ft. hand remote controls the solenoid valve
- Two speed pump designed for rapid cylinder advance
- Pump features a sturdy protective roll cage for use in the toughest environments
- Ideal for application when diesel fuel and/or remote control is required
- Manual valve is available

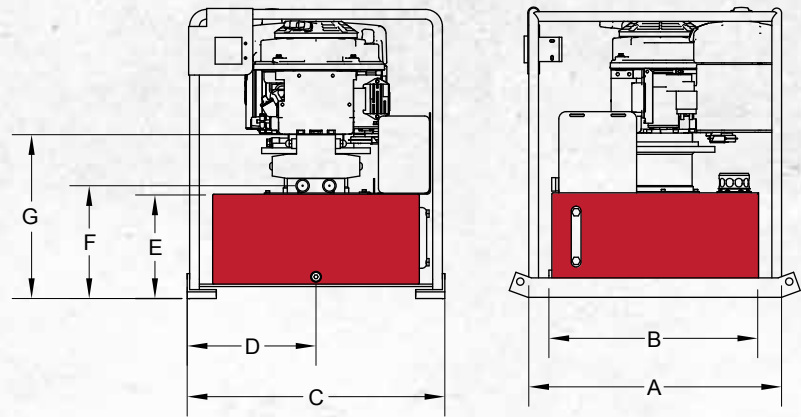

Motor Size (hp)	Usable Oil Capacity (gal)	Model Number	Max. Pressure Output (psi)	Pressure Rating (psi)		Oil Output Flow Rate (in ³ /min)		Valve Type	Valve Function	Rotation Speed (rpm)	Fuel Tank Size	dBA @ 7 m	Weight (lbs)
				1st Stage	2nd Stage	1st Stage	2nd Stage						
7.3	5	PDSL7305	10,000	700	10,000	600	200	Solenoid	Advance/ Hold/ Return	3,600	5L/1.32gal	76	215
7.3	5	PDSML7305	10,000	700	10,000	600	200	Solenoid	Advance/ Hold/ Return	3,600	5L/1.32gal	76	215
7.3	10	PDSL7310	10,000	700	10,000	600	200	Solenoid	Advance/ Hold/ Return	3,600	5L/1.32gal	76	249
7.3	10	PDSML7310	10,000	700	10,000	600	200	Solenoid	Advance/ Hold/ Return	3,600	5L/1.32gal	76	249
7.3	15	PDSL7315	10,000	700	10,000	600	200	Solenoid	Advance/ Hold/ Return	3,600	5L/1.32gal	76	283
7.3	15	PDSML7315	10,000	700	10,000	600	200	Solenoid	Advance/ Hold/ Return	3,600	5L/1.32gal	76	283

Model Number	Dimensions (in)						
	A	B	C	D	E	F	G
PDSL7305	26.57	21.5	20.94	10.47	11.50	12.43	15.47
PDSML7305	26.57	21.5	20.94	10.47	11.50	12.43	18.74
PDSL7310	28.25	23.37	27	13.5	12	12.93	17.375
PDSML7310	28.25	23.37	27	13.5	12	12.93	19.765
PDSL7315	28.25	26	27	13.5	12	12.93	17.375
PDSML7315	28.25	26	27	13.5	12	12.93	19.765

MAINTENANCE KITS

- Sets are portable for easy use in the plant or on the job site
- Custom fitted, rugged blow molded storage case
- 10 ton set has wheel for easy movement
- Designed for applications of pushing, spreading, pressing, and more



Capacity (tons)	Pump Capacity (psi)	Model Number	Rod			Number of attachments	Weight (lbs)
			Collapsed Height (in ²)	Extended Height (in ²)	Effective Area (in ²)		
4	8,000	J50040	11.00	15.75	0.998	14	46.0
10	10,000	J50100	13.63	19.75	2.411	13	81.0
20	10,000	J50200	11.77	16.93	5.14	16	206.0

*When extension tubes and/or offset attachments are used, the capacity is reduced.

FLANGE SPREADERS

- Designed for heavy duty industrial environment
- Adjustable jaw width for a wide range of applications and ease of use
- Easily transported
- Can be used with any single acting pump



Model Number	Capacity (tons)	Stroke (in.)	Oil Capacity (in.) ³	Maximum Flange Thickness (in.)
HFS05	5	1.00	1.00	2 X 2.3
HFS10	10	2.01	4.50	2 X 3.6

SPREADERS

- Designed to work in confined working space
- Ideal for wedging, prying, and opening
- High strength forged steel
- Spring return for easy operation

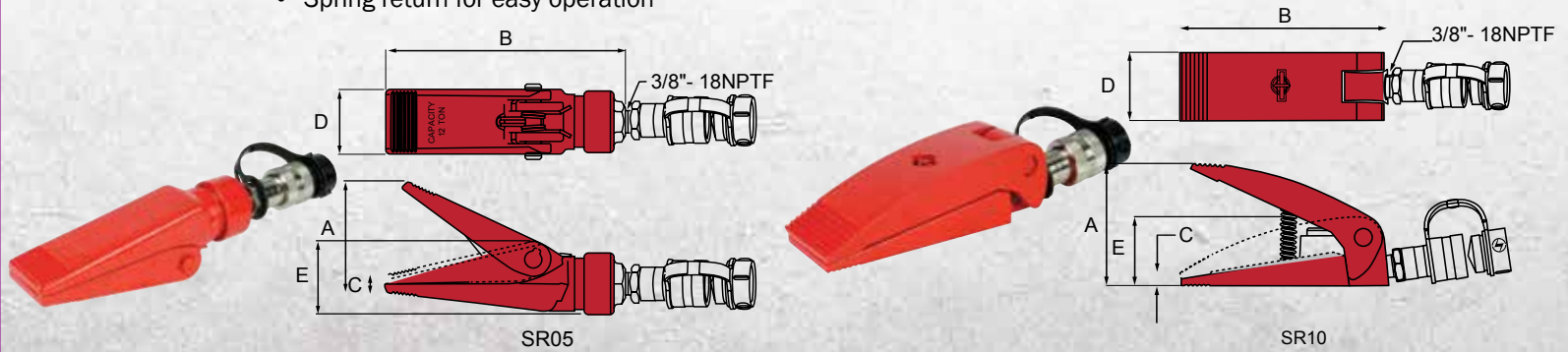

Cylinder Capacity (tons)	Model Number	Cylinder Effective Area (in ²)	Oil Capacity (in ³)	Dimensions (in)					Weight (lbs)
				A	B	C	D	E	
0.5	SR05	1.22	0.58	3.54	7.57	0.51	2.05	2.36	4.8
1	SR10	1.09	0.86	3.90	6.57	0.47	2.17	2.20	5.1

25/55/100 TON SHOP PRESSES

- Heavy steel welded construction
- Multi-position bed for work height adjustment
- Ideal for the removal or installation of gears, universal joints, pulleys, wrist pins, and other press jobs
- Excellent for bending, bonding, or straightening applications

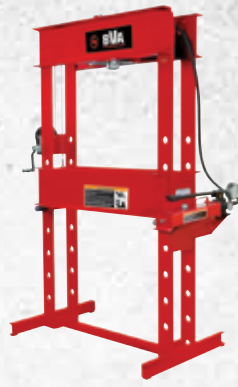

Capacity (Tons)	Model Number	Pump Type	Pump Model	Cylinder Model	Cylinder Stroke (In)	Bed Positions	Press Dimensions (H X L X W)	Working Space (Min - Max) (in)
Single Acting								
25	IMP2506	Manual	P1000	H2506	6	8	71" X 48" X 28"	4.5" X 47.25"
	IAP2506	Air	PA1500	H2506	6	8	71" X 48" X 28"	4.5" X 47.25"
	IEP2506	Electric	PEW0501T	H2506	6	8	71" X 48" X 28"	4.5" X 47.25"
	IMP2514	Manual	P2001	H2514	14	8	71" X 48" X 28"	4.5" X 47.25"
	IAP2514	Air	PA2000	H2514	14	8	71" X 48" X 28"	4.5" X 47.25"
	IEP2514	Electric	PEW0501T	H2514	14	8	71" X 48" X 28"	4.5" X 47.25"
	IEPS2514	Electric/Solenoid	PESL0501T	H2514	14	8	71" X 48" X 28"	4.5" X 47.25"
55	IMP5506	Manual	P2301	H5506	6	9	79" X 56" X 30"	14" X 55.5"
	IAP5506	Air	PA1500	H5506	6	9	79" X 56" X 30"	14" X 55.5"
	IEP5506	Electric	PEW0501T	H5506	6	9	79" X 56" X 30"	14" X 55.5"
	IAP5513	Air	PA3801	H5513	13	9	79" X 56" X 30"	14" X 55.5"
	IEP5513	Electric	PEW0501T	H5513	13	9	79" X 56" X 30"	14" X 55.5"
100	IMP10010	Manual	P8701	H10010	10	8	89" X 63" X 30"	11.25" X 51"
	IAP10010	Air	PA7550	H10010	10	8	89" X 63" X 30"	11.25" X 51"
	IEP10010	Electric	PEW1002T	H10010	10	8	89" X 63" X 30"	11.25" X 51"
	IEPS10010	Electric/Solenoid	PESL1002T	H10010	10	8	89" X 63" X 30"	11.25" X 51"
Double Acting								
25	IMPD2506	Manual	P2301M	HD2506	6	6	71" X 48" X 28"	4.5" X 47.25"
	IAPD2506	Air	PA3801M	HD2506	6	6	71" X 48" X 28"	4.5" X 47.25"
	IEPD2506	Electric	PEWM0501T	HD2506	6	6	71" X 48" X 28"	4.5" X 47.25"
	IEPDS2506	Electric/Solenoid	PESML0501T	HD2506	6	6	71" X 48" X 28"	4.5" X 47.25"
55	IEPD5513	Electric	PEWM1002T	HD5513	13	9	79" X 56" X 30"	14" X 55.5"
100	IEPD10010	Electric	PEWM1002T	HD10010	10	8	89" X 63" X 30"	11.25" X 51"
	IEPDS10010	Electric/Solenoid	PESML1002T	HD10010	10	8	89" X 63" X 30"	11.25" X 51"

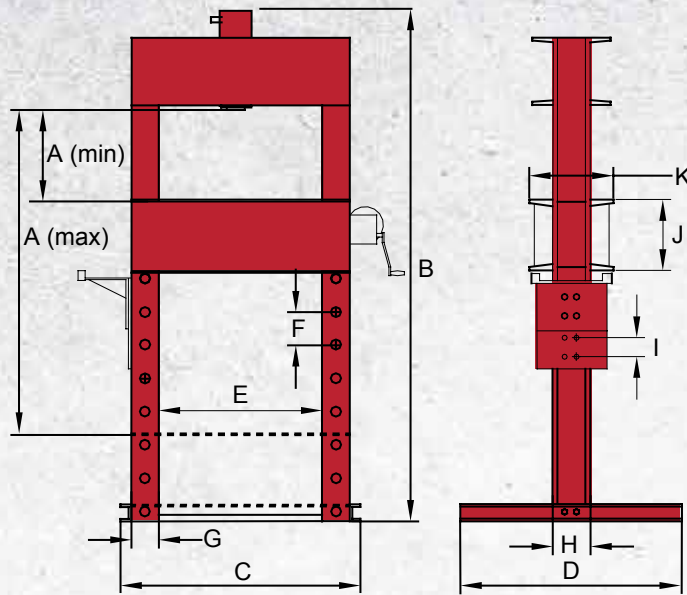

Model Number	Dimensions (in)												Weight (lbs)
	A (Min.)	A (Max.)	B	C	D	E	F	G	H	I	J	K	
Single Acting													
IMP2506	4.5	47.25	71	48	28	30	6	3	6.5	3	6	11.5	560
IAP2506	4.5	47.25	71	48	28	30	6	3	6.5	3	6	11.5	560
IEP2506	4.5	47.25	71	48	28	30	6	3	6.5	3	6	11.5	560
IMP2514	4.5	47.25	71	48	28	30	6	3	6.5	3	6	11.5	560
IAP2514	4.5	47.25	71	48	28	30	6	3	6.5	3	6	11.5	560
IEP2514	4.5	47.25	71	48	28	30	6	3	6.5	3	6	11.5	560
IEPS2514	4.5	47.25	71	48	28	30	6	3	6.5	3	6	11.5	560
IMP5506	14.0	55.5	79	56	30	35.4	6	4	9	3	10	14.8	760
IAP5506	14.0	55.5	79	56	30	35.4	6	4	9	3	10	14.8	760
IEP5506	14.0	55.5	79	56	30	35.4	6	4	9	3	10	14.8	760
IAP5513	14.0	55.5	79	56	30	35.4	6	4	9	3	10	14.8	760
IEP5513	14.0	55.5	79	56	30	35.4	6	4	9	3	10	14.8	760
IMP10010	14.0	55.5	79	56	30	35.4	6	4	9	3	10	14.8	770
IAP10010	11.3	51.0	89	63	30	35.5	8	-	10	-	12	16.0	1,550
IEP10010	14.0	55.5	79	56	30	35.4	6	4	9	3	10	14.8	770
IEPS10010	11.3	51.0	89	63	30	35.5	8	-	10	-	12	16.0	1,550
Double Acting													
IMPD2506	4.5	47.25	71	48	28	30	6	3	6.5	3	6	11.5	560
IAPD2506	4.5	47.25	71	48	28	30	6	3	6.5	3	6	11.5	560
IEPD2506	4.5	47.25	71	48	28	30	6	3	6.5	3	6	11.5	560
IEPDS2506	4.5	47.25	71	48	28	30	6	3	6.5	3	6	11.5	560
IEPD5513	4.5	47.25	71	48	28	30	6	3	6.5	3	6	11.5	560
IEPD10010	14.0	55.5	79	56	30	35.4	6	4	9	3	10	14.8	770
IEPDS10010	11.3	51.0	89	63	30	35.5	8	-	10	-	12	16.0	1,550

55 TON SHOP PRESS WITH MOVABLE WORK HEAD

- Heavy steel welded construction
- Cylinder moves from side to side and locks into position
- Multi-position bed for work height adjustment
- Pump, cylinder, hose and fittings are included

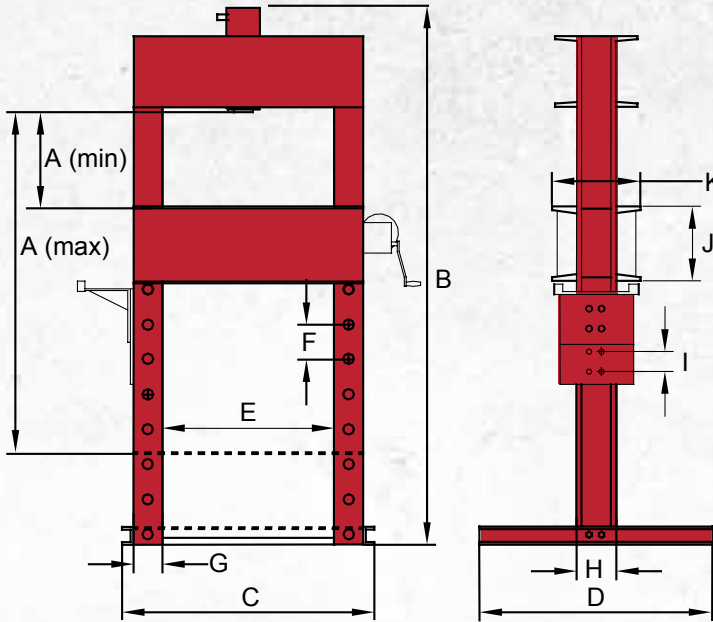

Capacity (Tons)	Model Number	Pump Type	Pump Model	Cylinder Model	Cylinder Stroke (In)	Bed Positions	Press Dimensions (H X L X W)	Working Space (Min - Max) (in)
Single Acting								
55	IMPR5506	Manual	P2001	H5506	6	7	78" X 46.5" X 30"	15.38" X 51.38"
	IAPR5506	Air	PA2000	H5506	6	7	78" X 46.5" X 30"	15.38" X 51.38"
	IEPR5506	Electric	PEW0501T	H5506	6	7	78" X 46.5" X 30"	15.38" X 51.38"
	IAPR5513	Air	PA2000	H5513	13	7	85" X 46.5" X 30"	15.38" X 51.38"
	IEPR5513	Electric	PEW0501T	H5513	13	7	85" X 46.5" X 30"	15.38" X 51.38"
	IEPRS5513	Electric/Solenoid	PESL0501T	H5513	13	7	85" X 46.5" X 30"	15.38" X 51.38"
Double Acting								
55	IAPDR5506	Air	PA3801M	HD5506	6	7	78" X 46.5" X 30"	15.38" X 51.38"
	IEPDR5513	Electric	PEWM1002T	HD5513	13	7	85" X 46.5" X 30"	15.38" X 51.38"
	IEPDRS5513	Electric/Solenoid	PESML1002T	HD5513	13	7	85" X 46.5" X 30"	15.38" X 51.38"

25 TON SHOP PRESS ACCESSORIES

CS25 includes:

- 300-002-229 • Rod forcing cap
- 300-002-807 • V push adapter
- 300-002-953 • Threaded adapter
- 300-002-510 • ¾" push adapter
- 300-002-511 • 1" push adapter
- AP25 • Arbor plates (in pairs)

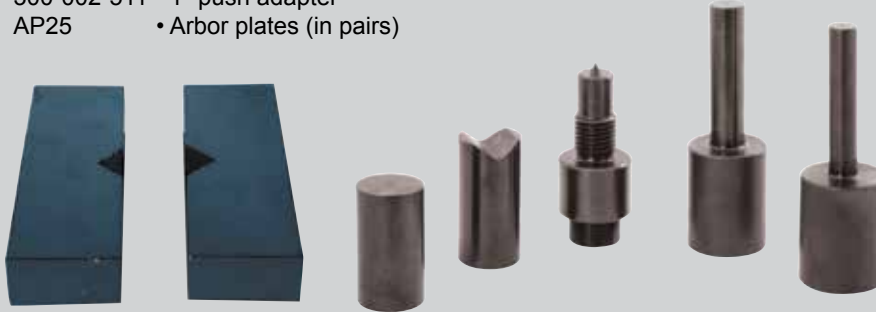

100 TON SHOP PRESS ACCESSORY

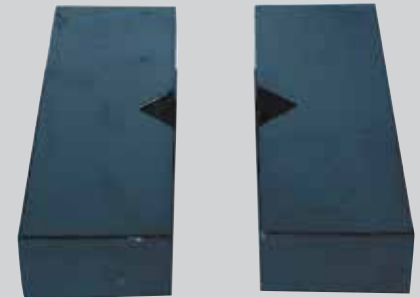

AP100 • ARBOR PLATES
(IN PAIRS)

55 TON SHOP PRESS ACCESSORIES

CS55 includes:

- 400-002-230 • Rod forcing cap
- 400-002-368 • Threaded adapter
- 400-002-757 • 1½" push adapter
- 400-002-756 • 1¼" push adapter
- 400-002-808 • V push adapter
- AP55 • Arbor plates (in pairs)

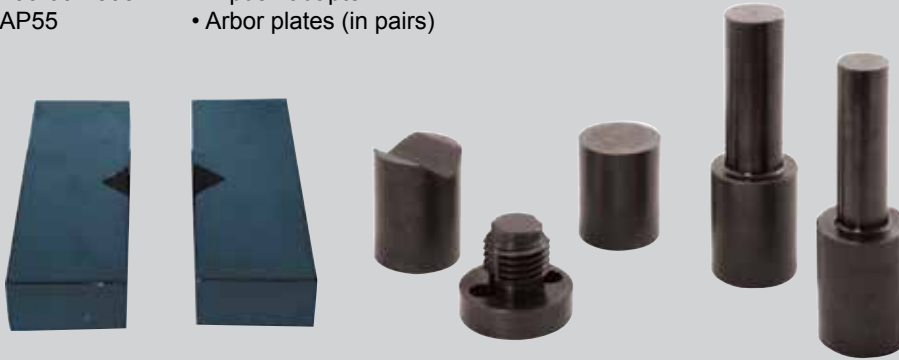

Model Number	Dimensions (in)												Weight (lbs)
	A (Min.)	A (Max.)	B	C	D	E	F	G	H	I	J	K	
Single Acting													
IMPR5506	15.38	51.38	78	46.5	30	35.75	6	4	9	3	10	15	955
IAPR5506	15.38	51.38	78	46.5	30	35.75	6	4	9	3	10	15	950
IEPR5506	15.38	51.38	78	46.5	30	35.75	6	4	9	3	10	15	1015
IAPR5513	15.38	51.38	85	46.5	30	35.75	6	4	9	3	10	15	991
IEPR5513	15.38	51.38	85	46.5	30	35.75	6	4	9	3	10	15	1048
IEPRS5513	15.38	51.38	85	46.5	30	35.75	6	4	9	3	10	15	1050
Double Acting													
IAPDR5506	15.38	51.38	78	46.5	30	35.75	6	4	9	3	10	15	955
IEPDR5513	15.38	51.38	85	46.5	30	35.75	6	4	9	3	10	15	1020
IEPDRS5513	15.38	51.38	85	46.5	30	35.75	6	4	9	3	10	15	1022

MANUAL BOTTLE JACKS

- Hydraulic system is protected from internal damage by a patented by-pass mechanism, U.S. Patent No.5,946,912
- Machined and polished cylinders with die-cut threads provide non-abrasive leak-free, durable performance
- Fabricated from hard-cast steel with heat-treated critical stress areas
- Unique cross-type forged release valve assures positive load control
- A wide, rugged base provides stability and strength

Capacity (ton)	Model Number	Min. Height (in)	Max. Height (in)	Hydraulic Lifting (in)	Extension Screw (in)	Base Size Length (in)	Base Size Width (in)	Weight (lbs)
12	J10125	9½	18½	6	3½	5¼	5½	17.5
	J10129	6	10½	3	1½	5¼	5½	14.9
20	J10205	9½	18½	6	3½	6¼	5½	27.5
	J10209	6½	11¼	3½	1½	6¼	5½	21.8
30	J10300	11	18	7	-	8½	6¾	53.5
50	J10500	9½	13¾	4¾	-	10¾	7¾	103.5



AIR/MANUAL BOTTLE JACKS

- Effortless air operation will greatly reduce operator fatigue and speed up the efficiency of industrial work
- A compact yet powerful air turbo motor U.S. Patent No. 5,341,723 is equipped to raise the load to the desired height efficiently, effortlessly, and safely
- Hydraulic system is protected from internal damage by a patented by-pass mechanism, U.S. Patent No.5,946,912
- Versatile "Quick Connector" design provides for easy removal of air hose from air motor allowing compact storage or remote operation
- All air bottle jacks have chrome plated rods



Capacity (ton)	Model Number	Min. Height (in)	Max. Height (in)	Hydraulic Lifting (in)	Extension Screw (in)	Base Size Length (in)	Base Size Width (in)	Input Air Pressure Range (psi)	Weight (lbs)
12	J18122	9½	18½	5½	3½	7¾	6½	110-175	28.6
20	J18202	9¾	18¾	5½	3¾	8¼	7¼	110-175	37.4
30	J18302	11	18	7	-	10¼	8¼	110-175	60.5
50	J18502	12	19	7	-	10¾	7-¾	110-175	128.5
100	J18992*	12	18½	6½	-	12¾	9-¾	110-175	205.9

*AIR OPERATED ONLY

TOE JACKS

- Heat treated and chrome plated medium-carbon steel cylinder
- Chrome plated rod promotes longer seal life and optimum performance
- U.S. Patented by-pass device protects hydraulic system from over traveling damage
- Hydraulic system is protected from internal damage by a patented by-pass mechanism, U.S. Patent No.5,946,912



Capacity (tons)	Model Number	Toe Saddle		Head Saddle		Hydraulic Lifting (in)	Base Size (L x W) (in)	Weight (lbs)
		Min. Height (in)	Max. Height (in)	Min. Height (in)	Max. Height (in)			
3	J13060	0.62	5.75	9.0	14.12	5.12	6.00 x 4.37	36.1
6	J13120	0.88	6.00	10.50	15.63	5.13	11.00 x 7.50	55.0
10	J13200	1.13	6.25	11.00	16.13	5.13	11.63 x 9.00	84.0
15	J13300	1.13	6.63	13.13	18.63	5.50	12.50 x 10.75	116.6

MINI JACKS

- Low profile mini jack
- Pocket size and lightweight
- Convenient for storage

Interchangeable saddle
on model J11050 and J11055



J11100



Capacity (tons)	Model Number	Minimum Height (in)	Maximum Height (in)	Hydraulic Lifting (in)	Base Size (L x W) (in)	Weight (lbs)
5	J11050	2.37	3.13	0.76	4.13 x 4.00	4.6
5	J11055	3.37	4.88	1.51	4.13 x 4.00	5.3
10	J11100	4.75	6.25	1.63	4.88 x 4.38	12.5
20	J11200	5.13	6.75	1.63	5.38 x 4.75	16.7

BEAD BREAKER

- 5" opening
- Works on single rimmed wheels
- Constructed from rugged steel
- Works with any 10,000 PSI pump
- Hydraulic pressure does all the unseating
- Light weight and portable



J22910

Capacity	Model	Maximum Rod Size	Hydraulic Oil Capacity	Product Size	Weight (lbs)
5 Ton	J22910	26"	250 mL	17½" X 5½" X 12"	36

J22953 Bead Breaker Combo

Includes:

- J22910 Bead breaker
- PA1500 Metal air pump
- CS3838C Hydraulic hose
- CH38 Hydraulic coupler set



FLOW CONTROL VALVES

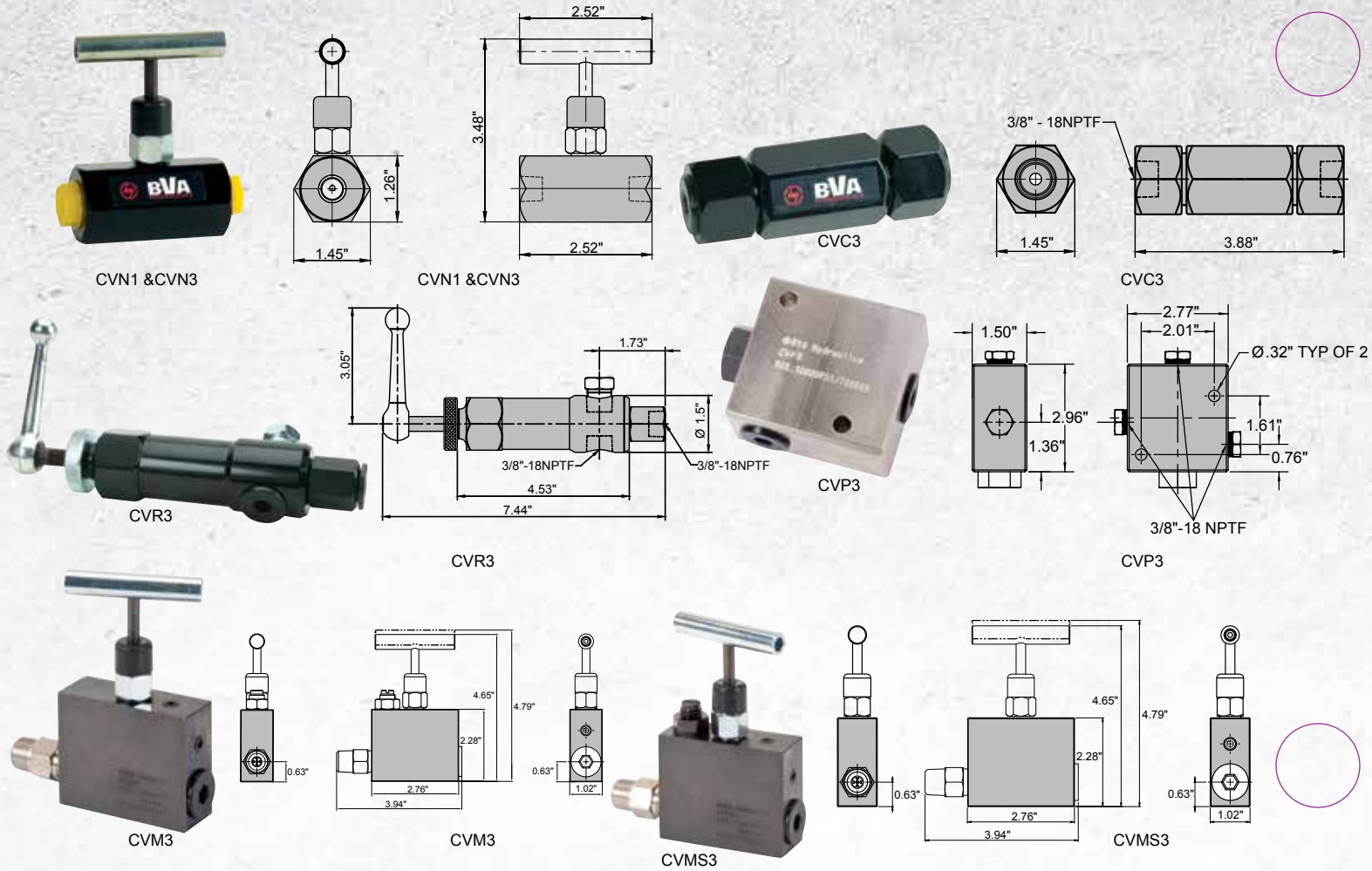

Valve Type	Model Number	Ports	Application	Hydraulic Symbol
Needle Valve	CVN1	1/4"-18NPTF	Controls cylinder speed and acts as temporary shut-off valve for load holding	
	CVN3	3/8"-18NPTF		
Check Valve	CVC3	3/8"-18NPTF	Allows flow in one direction only	
Pilot Operated Check Valve	CVP3	3/8"-18NPTF	Mounted in line to a cylinder and will hold pressure in cylinder in the event of pressure loss in the system. Most often used on double-acting cylinders with pilot port receiving pressure from a tee off of the cylinder retracting line. Pilot pressure ratio 15% or 6.5:1	
Pressure Relief Valve	CVR3	3/8"-18NPTF	Controls pressure developed by the pump in hydraulic loop. By-pass occurs when pre-set pressure is reached. Turns clockwise to increase pressure, counter clockwise to decrease	
Manual Operated Check Valve	CVM3	3/8"-18NPTF	Mounted in line to a cylinder and will hold pressure in the cylinder in the event of pressure loss in the system. Pressure is manually released.	
	CVMS3	3/8"-18NPTF	Mounted in line to a cylinder and will hold pressure in the cylinder in the event of pressure loss in the system. This model is equipped with high-pressure bypass. Pressure is manually released.	

MANIFOLDS

CM7



CM14

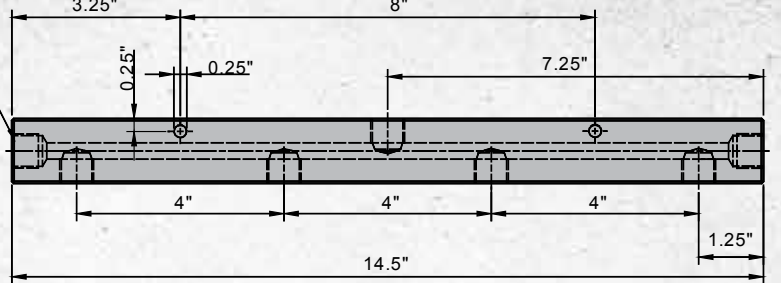
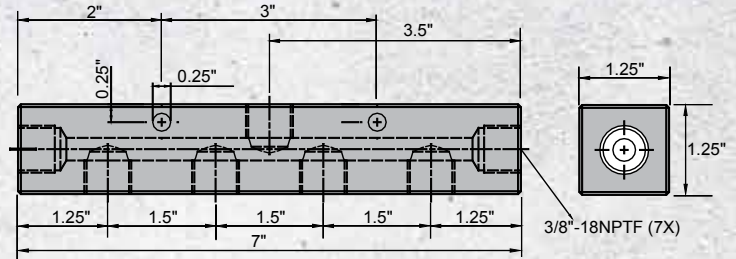
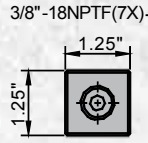

MFC2

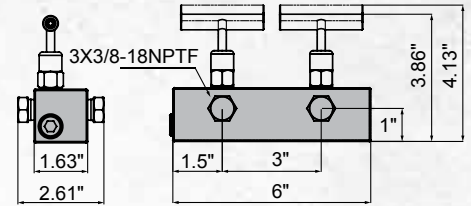

MFC4

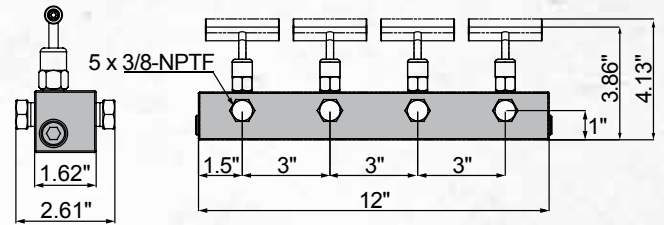

CMH6

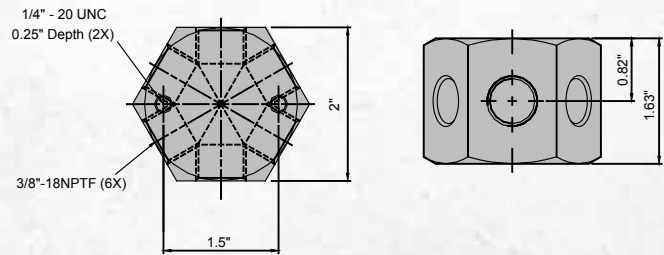

FCMH6

- Controls the flow of 5 hydraulic hoses from one central location
- Sturdy design for long product life
- Convenient carry handle

FCMH6



Manifold Type	Model Number	Number of Ports	Port Size	Mounting Hole
6-Port Hexagon Manifold	CMH6	6	3/8"-18NPTF	1/4"-20UNC
7" Long Manifold	CM7	7	3/8"-18NPTF	1/4"-20UNC
14" Long Manifold	CM14	7	3/8"-18NPTF	1/4"-20UNC
Manifold with Two Needle Valves	MFC2	3	3/8"-18NPTF	4.4
Manifold with Four Needle Valves	MFC4	5	3/8"-18NPTF	10.1
Spider Valves	FCMH6	6	3/8"-18NPTF	-

HYDRAULIC PRESSURE GAUGE

Gauge Type	Model Number	Face Diameter (in)	Thread (in)	Pressure Range		Graduation			
				(psi)	(bar)	Major Graduation (psi)	Minor Graduation (psi)	Major Graduation (bar)	Minor Graduation (bar)
Dry	GD2514	2.50	1/4"-18NPTF	0-10,000	0-700	1,000	200	100	10
	GD4014	4.00				2,000	100		
Wet	GW2514	2.50				1,000	200		
	GW4014	4.00				2,000	100		



PRESSURE & WEIGHT GAUGES

- Gauge indicates hydraulic pressure and weight
- Pressure and weight gauges can be ordered for all BVA cylinders
- Call if the cylinder is not listed

Model Number	Gauge Type	Face Diameter (in)	Use with Cylinders	Thread
GW2514-0100LB	WET	2.50	H0501 THROUGH H0509	1/4" - 18NPTF
GW2514-0224LB	WET	2.50	H1001 THROUGH H1014, HD1010, HD1012	1/4" - 18NPTF
GW2514-0314LB	WET	2.50	H1501 THROUGH H1514	1/4" - 18NPTF
GW2514-0515LB	WET	2.50	H2501 THROUGH H2514	1/4" - 18NPTF

GAUGE ADAPTER

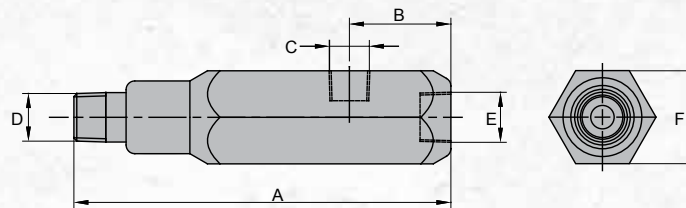

Model Number	Dimensions (in)					
	A	B	C	D	E	F
CF3814	5.12	1.38	1/4"-18NPTF	3/8"-18NPTF	3/8"-18NPTF	1.25

HYDRAULIC OIL

- Recommended for all
- BVA cylinders and pumps

Volume (gal)	Model Number	Viscosity Index (min)	Viscosity @ 100°F (S.U.S.)	Viscosity @ 210°F (S.U.S.)	ASTM Grade	Flash Point (°F)	Pour Point (°F)	API Gravity
1	F01	144	234	53	215	356	-49	30.8



SOLENOID VALVE

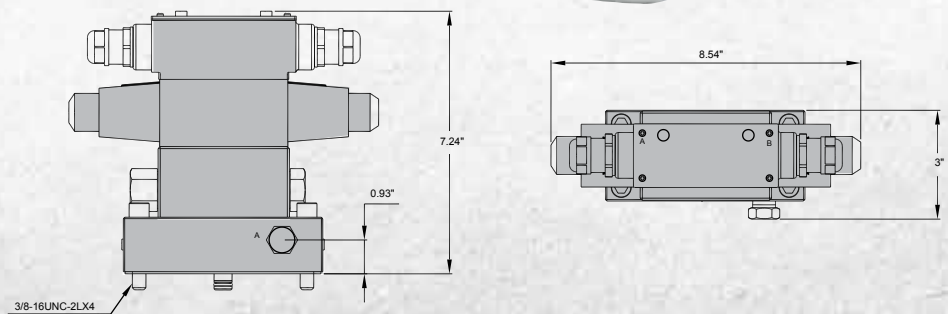

Use With Cylinder	Model Number	Valve Type	Valve Function	Hydraulic Symbol	Schematic Flow path			Weight (lbs)
Single Acting	PS33L	Solenoid 115VAC	Advance/ Hold/ Return					7.0
Double Acting	PS43L	Solenoid 115VAC	Advance/ Hold/ Return					7.0

PUMP MOUNTED MANIFOLD BLOCK

- Converts BVA pumps with pump mounted valves for use with remote mounted valves
- Comes with 4 mounting screws



CMR2

PRESSURE SWITCH



CVS1

- Automatically shuts off electric pump when predetermined system pressure is reached

Model Number	Adjustable Pressure Range	Electrical Rating	Port Size	Weight (lbs)
CVS1	1,000~10,150 psi	15 amp @ 250V max	¼"-18NPTF	1.32



PLASTIC DUST COVER

- Works with CH38
- Helps keep hydraulic oil clean for long equipment life

CDC38

PUMP ACCESSORIES

FOOT PEDAL (-FP2)

- For hands free pump operation
- Can be used with all pumps equipped with solenoid valves.

FOOT CONTROLS ON 10' CORD. THIS OPTION REPLACES THE HAND CONTROLS ON PESL AND PESML MODELS.



FP2

WIRELESS HAND HELD CONTROL (-W)

- Allows for increase mobility and safety
- Nominal range of 325 feet (greater with line of sight)
- Batteries last 100 hours with continuous keypress (2 AAA batteries)
- For hands free pump operation
- Can be used with all pumps equipped with solenoid valves

EXTERNAL PRESSURE ADJUSTMENT (-AS)

- Pressure can be adjusted externally (10,000 psi max)
- Works with single and double acting cylinders
- Can only be used with solenoid valves

Options	Description	Example ordering:
-FP2	Foot controls on 10' cord. This option replaces the hand controls on PESL and PESML models.	PESML3006T-3-FT2
-W	Wireless hand held control	PGSL1010-W
-AS	External pressure adjustment	PESL1002T-AS

HYDRAULIC COUPLERS

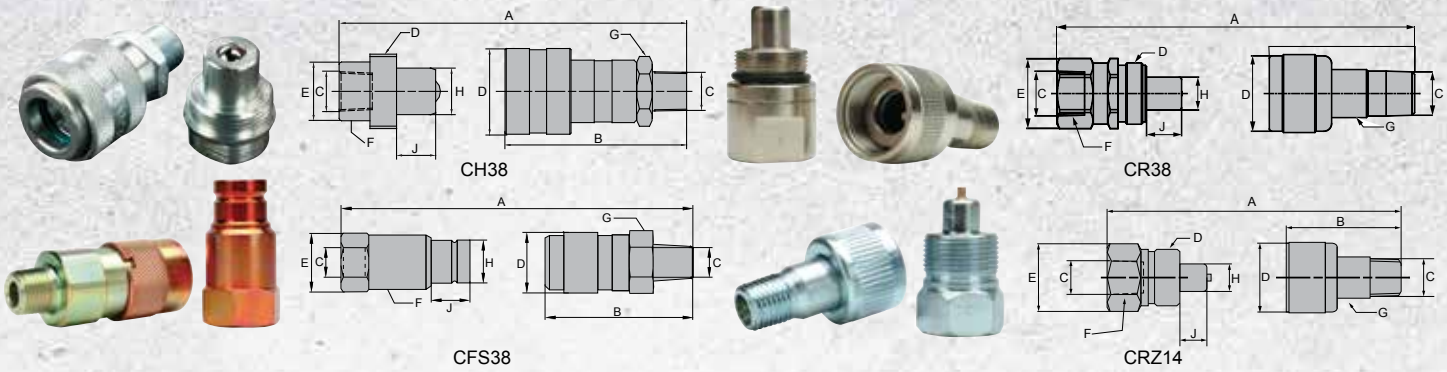

Coupler Type	Model Number			Dimensions (in)								
	Complete Set	Male Half	Female Half	A*	B	C	D	E	F	G	H	J
High-Flow Coupler	CH38	CH38M	CH38F	3.35	2.84	3/8"-18NPTF	1-3/16"-16	1.10	0.94	1.00	0.75	0.63
Flush-Face Coupler	CFS38	CFS38M	CFS38F	4.36	2.85	3/8"-18NPTF	1.19	1.21	1.06	1.12	0.79	0.63
Regular-Flow Coupler	CR38	CR38M	CR38F	3.15	2.20	3/8"-18NPTF	15/16"-20	1.04	0.94	0.73	0.50	0.53
Zinc Coupler	CRZ14	CRZ14M	CRZ14F	2.42	1.67	1/4"-18NPTF	13/16"-20	0.95	0.83	0.58	0.39	0.35

* Value A is total length when male and female couplers are connected.

HYDRAULIC HOSE



Hose I.D. (in)	Model Number		Hose End Fittings	Operating Pressure (psi)	Hose Length (ft)	Hose Oil Capacity (in ³)
	Rubber	Thermo-Plastic				
1/4"	CS1414	-	1/4"-18NPTF	10,000	6	3.53
	CS3814	CT3814	3/8"-18NPTF	10,000	6	3.53
	CS3814A	-	3/8"-18NPTF	10,000	2	1.18
	CS3814B	CT3814B	3/8"-18NPTF	10,000	3	1.77
	CS3814C	CT3814C	3/8"-18NPTF	10,000	10	5.89
	CS3814D	CT3814D	3/8"-18NPTF	10,000	20	11.78
3/8"	CS3814G	CT3814E	3/8"-18NPTF	10,000	30	17.76
	CS1438	-	1/4"-18NPTF	10,000	6	8.08
	CS3838	CT3838	3/8"-18NPTF	10,000	6	7.95
	CS3838C	CT3838C	3/8"-18NPTF	10,000	10	13.25
	CS3838D	CT3838D	3/8"-18NPTF	10,000	20	26.51
	CS3838E	CT3838E	3/8"-18NPTF	10,000	30	39.76
	CS3838F	-	3/8"-18NPTF	10,000	50	66.25

HOSE SETS



Hose I.D. (in)	Hose Model	Hose Length (ft)	Coupler		
			CH38M	CR38M	CRZ14M
1/4" Rubber	CS3814B	3	CS3814BM	CS3814BRM	-
	CS3814	6	CS3814M	-	CS3814QM
	CS3814C	10	CS3814CM	CS3814CRM	-
	CS3814D	20	CS3814DM	CS3814DRM	-
3/8" Rubber	CS3838	6	CS3838M	-	-
	CS3838C	10	CS3838CM	-	-
	CS3838D	20	CS3838DM	-	-
	CS3838E	30	CS3838CM	-	-
	CS3838F	50	CS3838FM	-	-
1/4" Thermo Plastic	CT3814	6	CT3814M	-	-
	CT3814C	10	CT3814CM	-	-

PUMP MOUNTED VALVES

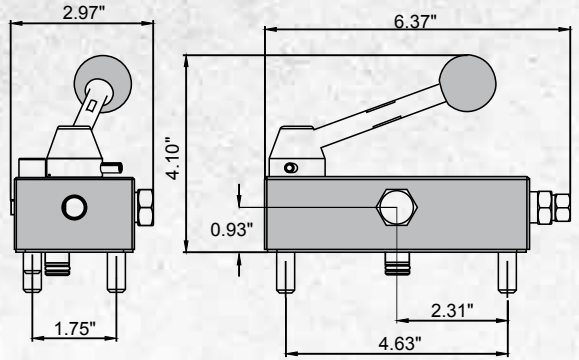
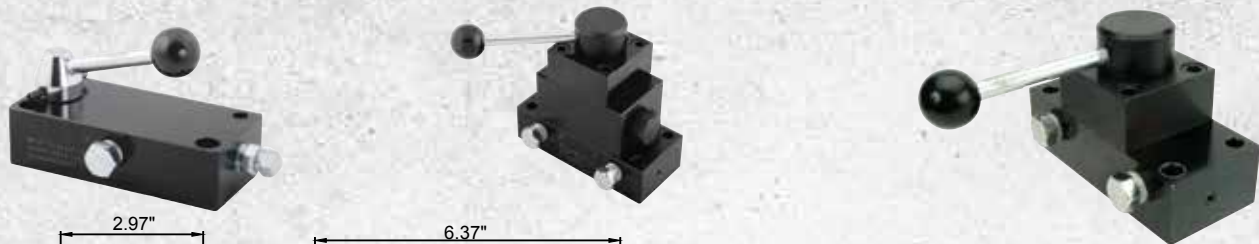

PW2

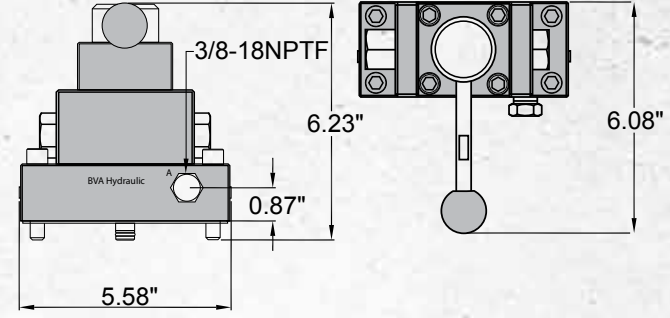

PW33L

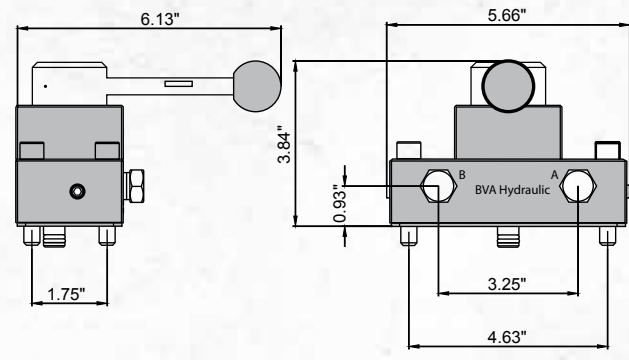

PW3 & PW4

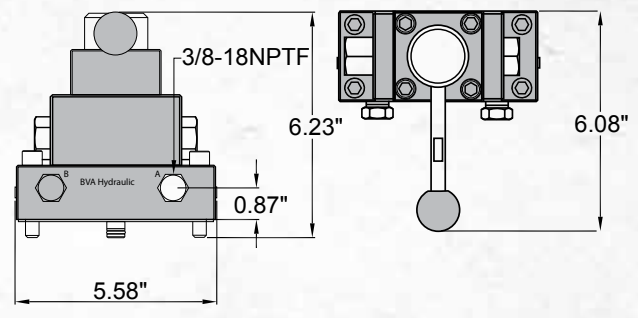

PW43L

Valve Operation	Valve Type	Use with Cylinder	Model Number	Hydraulic Symbol	Schematic Flow path			Weight (lbs)
Manual	2-Way, 2-Position	Single Acting	PW2				-	4
	3-way, 3-Position, Tandem center	Single Acting	PW3					4
	4-Way, 3-Position, Tandem center	Double Acting	PW4					3
	3-Way, 3-Position, Tandem center, Locking	Single Acting	PW33L					5.95
	4-Way, 3-Position, Tandem center, Locking	Double Acting	PW43L					5.95

REMOTE MOUNTED DIRECTIONAL CONTROL VALVES

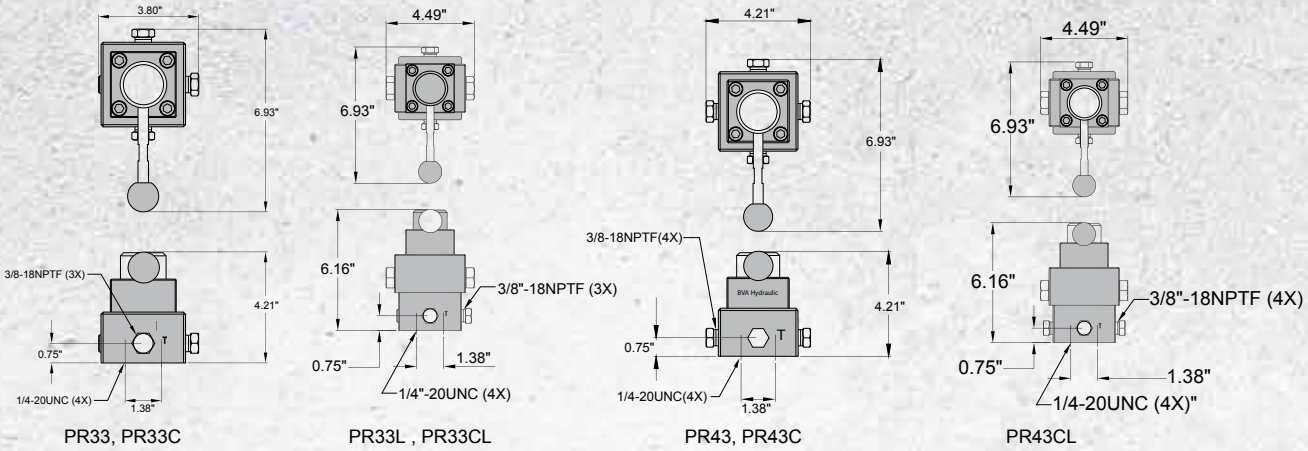

Valve Operation	Valve Type	Use With Cylinder	Model Number	Hydraulic Symbol	Schematic Flow path			Weight (lbs)
Manual	3-Way, 3 Position, Tandem center	Single Acting	PR33					3.53
	3-Way, 3 Position, Closed center		PR33C					3.53
	3-Way, 3 Position, Tandem center, Locking		PR33L					5.73
	3-Way, 3 Position, Closed center, Locking		PR33CL					5.73
	4-Way, 3 Position, Tandem center	Double Acting	PR43					3.53
	4-Way, 3 Position, Tandem center, Locking		PR43L					5.73
4-Way, 3 Position, Closed center	PR43C						3.53	
4-Way, 3 Position, Tandem, Closed center, Locking	PR43CL						5.73	



PR33











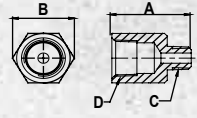

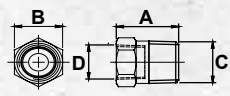

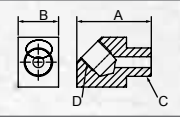

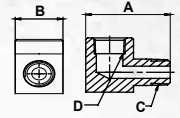

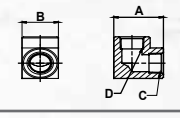

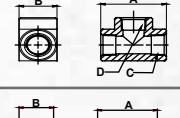
PR43C

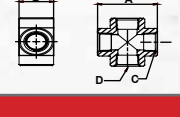

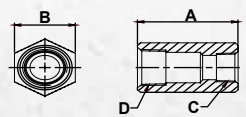
PR43L

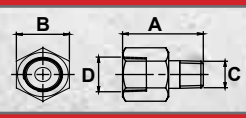
FITTINGS

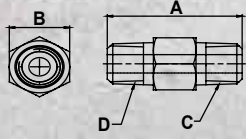
Fitting Type	Model Number	Dimension					
		A (in)	B (in)	C	D		
Adaptors							
	Adaptor 1/2"-14 Female 3/8"-18 Male - NPTF	FT108	1.69	1.14	Male 3/8"-18NPTF	Female 1/2"-14NPTF	
	Adaptor 1/2"-14 Female 1/4"-18 Male - NPTF	FT118	1.69	1.14	Male 1/4"-18NPTF	Female 1/2"-14NPTF	
Bushings							
	Bushing	CB1438	0.87	0.67	Male 3/8"-18NPTF	Female 1/4"-18NPTF	
	Bushing	CB1412	1.10	0.87	Male 1/2"-18NPTF	Female 1/4"-18NPTF	
	Bushing	CB3812	1.10	0.87	Male 1/2"-18NPTF	Female 3/8"-18NPTF	
Connectors							
	2 way 45° Connector Street Elbow, 3/8" to 3/8"-NPTF	FT045	1.89	1.02	Male 3/8"-18NPTF	Female 3/8"-18NPTF	
	2 way 90° Connector Street Elbow, 3/8" to 3/8"-NPTF	FT101	1.81	1.02	Male 3/8"-18NPTF	Female 3/8"-18NPTF	
	2 way 90° Connector Elbow, 3/8" to 3/8" - NPTF	FT107	1.40	1.02	Female 3/8"-18NPTF	Female 3/8"-18NPTF	
	3 Way Connector 3/8" to 3/8" - NPTF	FT106	1.77	1.02	Female 3/8"-18NPTF	Female 3/8"-18NPTF	
	4 Way Connector Cross, 3/8" to 3/8" - NPTF	FT105	1.77	1.02	Female 3/8"-18NPTF	Female 3/8"-18NPTF	
Couplings							
	Coupling Reducing Connector, 3/8" to 1/4"-NPTF	FT102	1.18	1.02	Female 1/4"-18NPTF	Female 3/8"-18NPTF	
	Coupling Reducing Connector, 1/2" to 3/8" - NPTF	FT112	1.89	1.14	Female 1/2"-14NPTF	Female 3/8"-18NPTF	
	Coupling 3/8" to 3/8" - NPTF	FT103	1.18	1.02	Female 3/8"-18NPTF	Female 3/8"-18NPTF	
Fitting							
	Fitting	CA3814	1.38	0.91	Male 1/4"-18NPTF	Female 3/8"-18NPTF	
Male Connectors							
	Male Connector Hex Nipple, 1/4" to 1/4" - NPTF	FT104	1.50	0.67	Male 1/4"-18NPTF	Male 1/4"-18NPTF	
	Male Connector Hex Nipple, 3/8" to 3/8" - NPTF	FT114	1.50	0.75	Male 3/8"-18NPTF	Male 3/8"-18NPTF	
	Male Connector Hex Nipple, 1/4" to 3/8" - NPTF	FT124	1.45	0.75	Male 1/4"-18NPTF	Male 3/8"-14NPTF	

BVA CROSS REFERENCE CHART

Ton	BVA	ENERPAC	Power Team	Simplex
Single Acting Cylinders				
5	H0500	RC-50	-	R50
	H0501	RC-51	C51C	R51
	H0503	RC-53	C53C	R53
	H0505	RC-55	C55C	R55
	H0507	RC-57	C57C	R57
	H0509	RC-59	C59C	R59
10	H1001	RC-101	C101C	R101
	H1002	RC-102	C102C	R102
	H1004	RC-104	C104C	R104
	H1006	RC-106	C106C	R106
	H1008	RC-108	C108C	R108
	H1010	RC-1010	C1010C	R1010
	H1012	RC-1012	C1012C	R1012
	H1014	RC-1014	C1014C	R1014
15	H1501	RC-151	C151C	-
	H1502	RC-152	C152C	R152
	H1504	RC-154	C154C	R154
	H1506	RC-156	C156C	R156
	H1508	RC-158	C158C	-
	H1510	RC-1510	C1510C	R1510
	H1512	RC-1512	C1512C	-
	H1514	RC-1514	C1514C	R1514
25	H2501	RC-251	C251C	R251
	H2502	RC-252	C252C	R252
	H2504	RC-254	C254C	R254
	H2506	RC-256	C256C	R256
	H2508	RC-258	C258C	R258
	H2510	RC-2510	C2510C	R2510
	H2512	RC-2512	C2512C	R2512
	H2514	RC-2514	C2514C	R2514
30	H3008	RC-308	-	R308
	H5502	RC-502	C552C	R552
	H5504	RC-504	C554C	R554
	H5506	RC-506	C556C	R556
55	H5513	RC-5013	C5513C	R5513
	H7506	RC-756	C756C	R756
	H7513	RC-7513	C7513C	R7513
75	H10006	RC-1006	C1006C	R1006
	H10010	RC-10010	C10010C	R10010

Ton	BVA	ENERPAC	Power Team	Simplex
Threaded Cylinders				
10	HT1006	-	C106CBT	-
	HT1010	-	C1010CBT	-
Aluminum Cylinders				
30	HU3002	RAC-302	RA302	-
	HU3004	RAC-304	RA304	-
	HU3006	RAC-306	RA306	RAS306B
50	HU5002	RAC-502	RA552	RAS502A
	HU5004	RAC-504	RA554	-
	HU5006	RAC-506	RA556	RAS508A
	HU5010	RAC-5010	RA5510	-
75	HU7504	-	-	-
	HU7506	-	-	-
100	HU10002	RAC-1002	RA1002	RAS1002A
	HU10006	RAC-1006	RA1006	RAS1008A
	HU10010	RAC-10010	-	-
Low Profile Cylinders				
10	HL1001	RCS-101	RSS101	RLS101
20	HL2002	RCS-201	RSS202	RLS201
30	HL3002	RCS-302	RSS302	RLS302
50	HL5002	RCS-502	RSS502	RLS502
100	HL10002	RCS-1002	RSS1002	RLS1002
Flat Body Cylinders				
5	HF0503	RSM-50	RLS50	-
	HF0503B kit	-	-	-
10	HF1005	RSM-100	RLS100	RFS10
	HF1005B kit	-	-	-
20	HF2005	RSM-200	RLS200	RFS20
	HF2005B kit	-	-	-
30	HF3005	RSM-300	RLS300	RFS30
	HF3005B kit	-	-	-
50	HF5006B	RSM-500	RLS500S	RFS50
75	HF7506	RSM-750	RLS750S	RFS75
100	HF10006	RSM-1000	RLS1000S	RFS100
150	HF15006	RSM-1500	RLS1500S	RFS150
Pull Cylinders				
2	HP0205	BRC-25	RP25	RP25
5	HP0505	BRC-46	RP55	RP55
10	HP1006	BRC-106	-	-
Ton	BVA	ENERPAC	Power Team	Simplex

Hollow Hole Cylinders				
12	HC1201T	RCH-120	RH120	RC120
	HC1202T	RCH-121	RH121	RC121
	HC1202XT	RCH-1211	RH121T	RC1211
	HC1203XT	RCH-123	RH123	RC123
20	HC2002T	RCH-202	RH202	RC202
	HC2006T	RCH-206	RH206	RC206
	HC3002T	RCH-302	RH302	RC302
30	HC3006T	RCH-306	RH306	RC306
	HC6003T	RCH-603	RH603	RC603
60	HC6006T	RCH-606	RH606	RC606
	HC10003T	RCH-1003	RH1003	RC1003
Lock Nut Cylinders				
55	HLN5502	CLL-502	R552L	RLN502
	HLN5504	CLL-504	-	-
	HLN5506	CLL-506	R556L	RLN506
	HLN5508	CLL-508	-	-
	HLN5510	CLL-5010	R5510L	RLN5010
	HLN5512	CLL-5012	-	-
100	HLN10002	CLL-1002	R1002L	RLN1002
	HLN10004	CLL-1004	-	-
	HLN10006	CLL-1006	R1006L	RLN1006
	HLN10008	CLL-1008	-	-
	HLN10010	CLL-10010	R10010L	RLN10010
	HLN10012	CLL-10012	-	-
Double Acting Cylinders				
10	HD1010	RR-1010	RD1010	RDA1010
	HD1012	RR-1012	-	-
30	HD3008	RR-308	-	RDA308
	HD3014	RR-3014	RD2514	RDA3014
55	HD5506	RR-506	RD556	RDA556
	HD5513	RR-5013	RD5513	RDA5512
	HD5520	RR-5020	RD5518	RDA5523
75	HD7506	RR-756	-	-
	HD7513	RR-7513	-	-
100	HD10006	RR-1006	RD1006	RDA1006
	HD10013	RR-10013	RD10013	RDA10012

BVA® is a registered trademark of SF Companies.
 Enerpac® is a registered trademark of the Actuant Corporation.
 Power Team® is a registered trademark of SPX Corporation.
 Simplex® is registered of the Actuant Corporation.

For comparison purposes only. Products are not identical.

BVA	ENERPAC	Power Team	Simplex
Hand Pumps			
P601S	P-39	P12	P41
P1201S	P-391	P55	-
P350	P-142	-	-
P1000	P-392	P59	P60
P2001	P-80	P157	P140 P82
P2301	P-80	P159	P82
P4301	P-801	P157	P230
P8701	P-462	P460	P461
P2301M	P-84	P157D	P230D
P8701M	P-464	P460D	P461D
P240L	P-18	-	-
Air Pumps			
PA600	PA-133	PA9	-
PA600H	-	PA9H	-
PA1500	-	PA6	GA90
PA1500L	PARG-1102N	PA6R	GA90R
PA1500M	-	PA6DM	-
PA2000	PATG-1102N	-	-
PA3801	PATG-1105N	PA6-1	GA9230
PA3801L	-	-	GA9230R
PARD1701	-	PA172	-
PARD1703	-	PA174	-

To view complete cross over list go to www.bvahydraulics.com

For comparison purposes only. Products are not identical. BVA® is a registered trademark of SF Companies. Enerpac® is a registered trademark of the Actuant Corporation. Power Team® is a registered trademark of SPX Corporation. Simplex® is registered of the Actuant Corporation

Key to measurements		
Weight:		Other measurements:
1 pound (lb.)	=0.4536 kg	1 in =25.4 mm
1 kg	=2.205 lbs	1mm =0.039 in
1 ton (short, US)	=2000 lbs	1 in² =6.452 cm²
1 ton (metric)	=2205 lbs	1 cm² =0.155 in²
Volume:		Pressure:
1 in³	=16.387 cm³	1 psi (lb/in²) =0.69 bar
1 cm³	=0.061 in³	1 bar =14.5 psi
1 liter	=61.02 in³	1 kPa =0.145 psi
1 gal (US, liquid)		Temperature:
=3.785 liter		0°F = (0°C x 1.8)+32
=3785 cm³		0°C = (0°F - 32) ÷ 1.8

Cylinder Rod Speed

$$\text{Formula } V = A / Q$$

$$\text{Cylinder Rod Speed (sec/in)} = \frac{\text{Cylinder Effective Area (in}^2\text{)}}{\text{Oil Output Flow Rate (in}^3\text{/min)}} \times \frac{60 \text{ (sec)}}{1 \text{ (min)}}$$

Force

$$\text{Formula } F = P \times A$$

$$\text{Force (lbs)} = \frac{\text{Hydraulic Working Pressure (lb/in}^2\text{)}}{\text{Cylinder Effective Area (in}^2\text{)}}$$

Cylinder Oil Capacity

$$\text{Oil Capacity (in}^3\text{)} = \frac{\text{Cylinder Effective Area (in}^2\text{)}}{\text{Cylinder Stroke (in)}}$$

Cylinder Effective Area

$$\text{Cylinder Effective Area} = \frac{\pi}{4} \times (\text{Cylinder Bore Diameter})^2$$

where, $\pi = 3.14159$

SAFETY FIRST!

- Study, understand, and follow all instructions before operating this device.
- Do not exceed rated capacity. Use only on hard, level surfaces.
- Immediately after lifting, support the load with appropriate means.
- Failure to heed these markings may result in personal injury and/or property damage

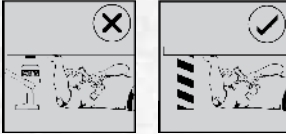

▲ Never place any part of your body under the load. Ensure the load is on a solid support before venturing under.

Cylinders



▲ Provide a solid support for the entire cylinder base area. Use cylinder base attachment for more stability.

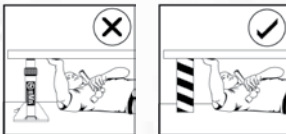

▲ As with jacks, never place any part of your body under the load. Load must be on cribbing before venturing under.

Pumps

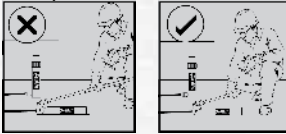

▲ Do not use handle extender. Hand pumps should be easy to operate when used correctly.

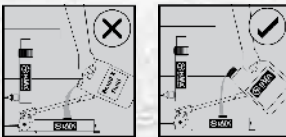

▲ Use only genuine BVA hydraulic oil. The wrong fluid can destroy your seals and pump and will render your warranty null and void.

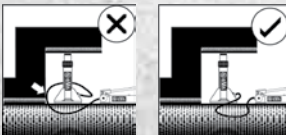

▲ Keep hoses away from the areas beneath loads.

SAFETY INSTRUCTIONS

General

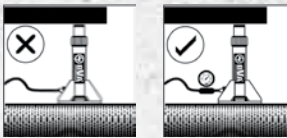

▲ Do not override the factory setting of relief valves. Always use a gauge to check system pressure.

Jacks

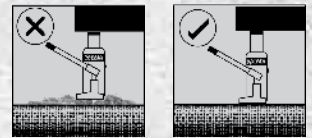

▲ Provide a level and solid support for the entire jack base area.

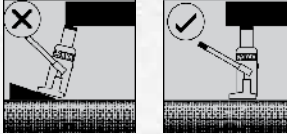

▲ The entire jack saddle must be in contact with load. Movement of the load must be in the same direction as jack rod.

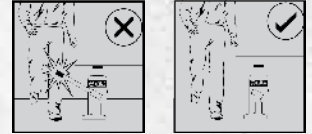

▲ Remove the jack handle when it is not being used.

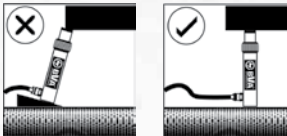

▲ The entire cylinder saddle must be in contact with the load. Movement of the cylinder must be parallel with the movement of the load.



▲ Do not use cylinder without saddle. This will cause rod to "mushroom" Saddles distribute load evenly on the rod.

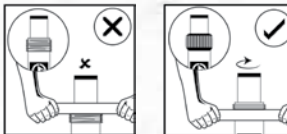

▲ Always protect cylinder threads for use with attachments.



▲ Keep hydraulic equipment away from open fire and temperatures above 150°F (65°C).

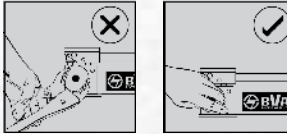

▲ Close release valve finger tight. Using force will damage the valve.

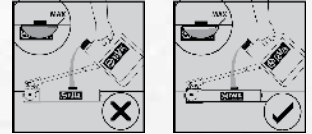

▲ Fill pump only to recommended level. Fill only when connected cylinder is fully retracted.

Hoses and Couplers

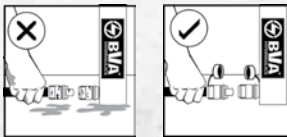

▲ Clean both coupler parts before connecting. Use dust caps when coupler parts are not connected.

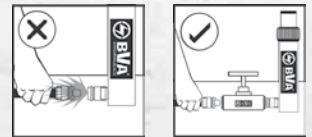

▲ Detach cylinder only when fully retracted or use shut-off valves or safety valves to lock-in cylinder pressure.



▲ Do not kink hoses. Bending radius should be at least 4½". Do not drive over or drop heavy objects on the hoses.

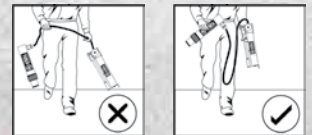

▲ Don't lift hydraulic equipment by the hoses.



Kansas City, MO
Sales, Marketing, Engineering, and Distribution

Global Locations



USA , Canada, Mexico , Central & South America

10939 N. Pomona Ave.
Kansas City, MO 64153
Tel. 888-332-6419, 816-891-6390
Fax.816-891-6599
Email: sales@bvahydraulics.com



EUROPE

Tussenrimer 20, 4704 SR Roosendaal
The Netherlands
Tel. 31-165-583-300
Fax. 31-165-583-310
Email: sales@sfeu.nl



AUSTRALIA

15 Viewtech Place
Rowville 3178, Victoria
Australia
Tel. 61-3-9755-8277
Fax. 61-3-9755-8219



ASIA

7F., NO618 Ruei Guang Road
Nei Hu District, Taipei City 114
Taiwan R.O.C.
Tel. 886-2-8751-7888
Fax. 886-2-8751-7999



BUILT TO LAST

