



**Air Driven
Double Diaphragm
Pumps**

ALL-FLO

The BEST Diaphragm Pumps in the World!

ABOUT ALL-FLO

ALL-FLO is committed to the pursuit of designing and manufacturing the highest quality product available to industry. Since the beginning in 1986, ALL-FLO engineers have used their extensive knowledge of today's engineered materials, advanced air system logic and manufacturing techniques to develop the superior group of lube-free, air-operated diaphragm pumps found in this catalog. Every pump is performance engineered and quality built to provide trouble-free service under the toughest conditions.

SIMPLE OPERATION

Double diaphragm pumps are operated by compressed air or any non-flammable compressed gas. The pumping stroke begins as air is delivered by the air distribution system, putting pressure on one diaphragm and then the opposite diaphragm. The two diaphragms are linked together by a common rod. The pumping stroke on one side is simultaneously the suction stroke on the opposing diaphragm alternately drawing fluid in one side while discharging fluid from the other side.

PATENTED -
Covered by one or both:
Patent No. 5758563
Patent No. 5232352

ADVANTAGES...MAKE ALL-FLO FIRST CHOICE:

- Pumps Anything That Will Pour
- Wide Range of Pump Types and Sizes
- Patented Lube-Free Air System
- Will Not Stall at Slow Speeds
- 100% Tested Prior to Shipment
- Self-Priming
- Non-Electrical
- Runs Dry Without Damage
- Infinitely Variable Flow Rate
- Intermittent Operation or Continuous Duty
- Pumps Fluids Which Contain Particles
- Pumps High Viscosity Fluids
- Reduced Solvent Flash-Off
- Simple Modular Design
- Dual Manifold Capability for 3/8", 1/2" and 1" Models
- Parts Interchangeable Between Models and Sizes
- Large Solids handling through the Max-Pass™ valve system - 3/8", 1/2" and 1" Performance Plus Pumps

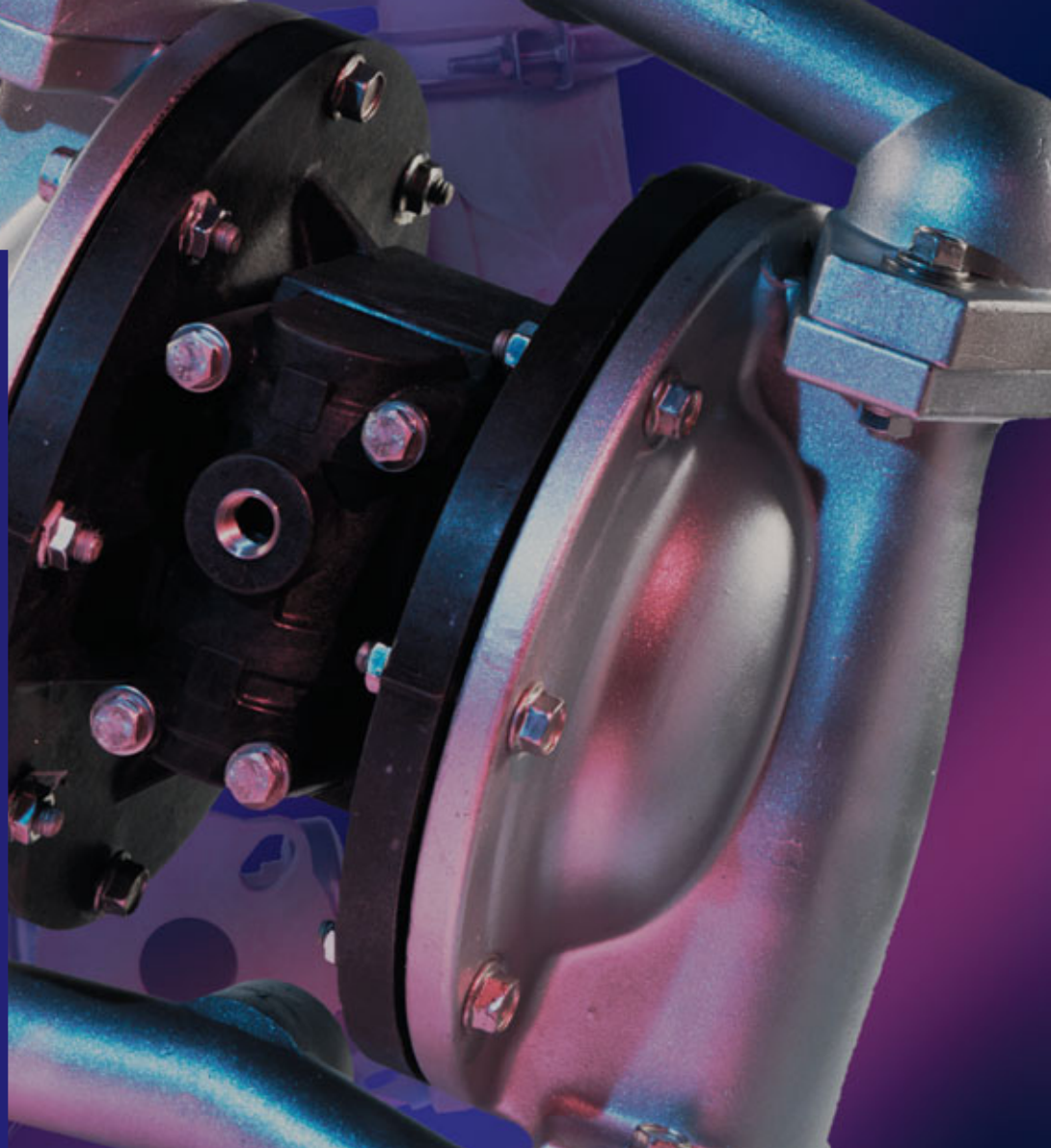
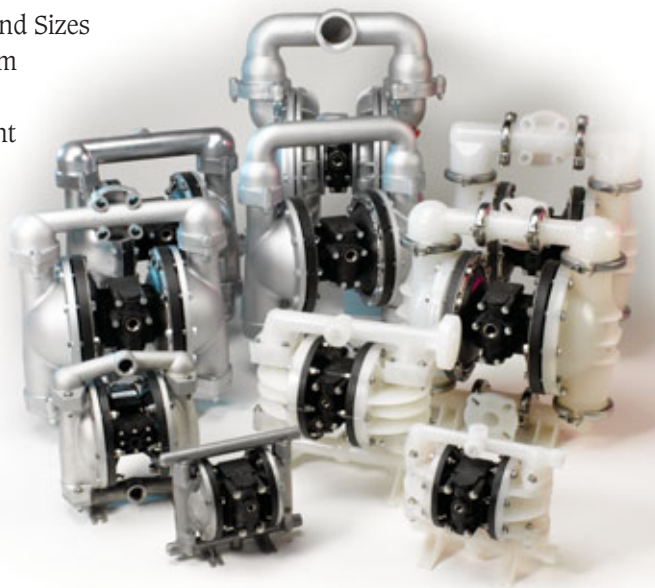

PERFORMANCE ENGINEERED

ALL-FLO HAS THE RIGHT PUMP FOR ANY APPLICATION...

Classic Performance pumps offer years of trouble-free service.

Performance Plus pumps offer trouble-free service plus enhanced operating features.

The **Specialty Performance** 3/8" pump – the revolution in low flow pump technology.

NO STALLOUTS DUE TO FREEZING...

Stallout due to ice formation in the air system is virtually eliminated due to the insulating quality of all plastic construction plus the ability to slow air expansion and velocity without compromising performance.

NO VENT HOLES...

There are no vent holes in the ALL-FLO air valve. Vent holes needed to prevent stalling in competitive pumps allow corrosive fumes to enter and destroy valuable components. Additionally, if a diaphragm ruptures, fluid leakage cannot be routed to a safe containment zone. The sealed ALL-FLO air valve allows containment of fluid and prevents fumes from entering air system.

PERFORMANCE ENGINEERED PTFE DESIGN...

Superior PTFE overlay design does NOT require reduced diaphragm rod stroke, which reduces pump capacity by 20% on competitive pumps. All back-up diaphragms for PTFE overlays are Santoprene which offers a chemically resistant "second line of defense".

THERMOPLASTIC DIAPHRAGMS...

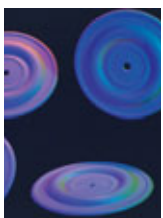

offer superior chemical and abrasion resistance and increased cycle life. The wide range of applications that these materials can address also make ordering the correct pump much easier.

MAINTENANCE TIME REDUCED...

due to uniform product design. All models share the same design concept from 1/2" pumps to 3" pumps. The size of the components just get larger. If you know how to rebuild one size... you can easily rebuild any size.

PATENTED LUBE-FREE, NON-STALLING AIR SYSTEM

THE HEART OF THE PUMP...

gives reliable, trouble-free operation in all sizes of pumps.



Competitive pumps claim lube-free operation, but operation manuals note that lubrication is always needed during "certain operating conditions." ALL-FLO's air system is truly lube-free and will not stall at slow speeds.

LUBE-FREE OPERATION...

throughout the life of the pump is achieved by using dissimilar plastic materials within the air system and a shuttle mechanism constructed of lubrication filled materials to maximize lubricity. Flatness and surface finishes are held to strict engineering tolerances which also reduce the coefficient of friction resulting in trouble-free operation and increased air efficiency.

NO AIR LOST...

when fluid discharge lines are closed. Air system seals completely and prevents air consumption when pump is not transferring fluid. The low coefficient of friction between the air system components also helps reduce air consumption.

ALL PLASTIC AIR SYSTEMS USED IN BOTH METALLIC AND PLASTIC...

pumps are corrosion resistant and will not be destroyed in case of diaphragm rupture, spills or corrosive atmospheres.

STATE-OF-THE-ART SEAL TECHNOLOGY USED IN THE AIR SYSTEM...

is more tolerant of dirty and wet air supplies. Lip seals and high wear elastomers offer outstanding cycle life.

STALLING IS PREVENTED...

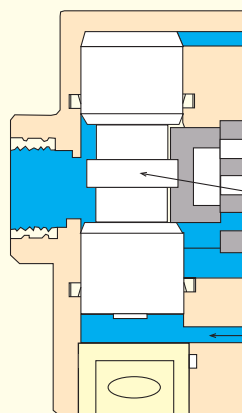

as the pilot supply air maintains a constant pressure against the air valve spool throughout the discharge stroke preventing the spool/shuttle combination from moving into a neutral or stall position. ALL-FLO pumps do not require reset buttons or magnets to insure continuous pump operation — *only air.*

Valve Spool

Pilot Supply Air Prevents Stalling

INVENTORY REDUCTION...

because metallic and plastic pumps all share the same air systems, diaphragms, O-rings, balls and in some cases valve seats. To further help minimize inventory requirements, 1-1/2" and 2" models share the same air systems, diaphragms and valve seat components.

ALL PLASTIC AIR SYSTEMS...

in both metallic and plastic pumps prevent destruction of air system components from corrosive atmospheres or diaphragm ruptures. No brass or aluminum components are used within the air systems.

SIMPLE ORDERING CODES...

confused by complex ordering codes required by some manufacturers — not with ALL-FLO. All models are easily associated with materials and have a simplified model number as shown on page 4.

MAX-PASS™ VALVE SYSTEM FOR LARGE SOLIDS...



Look for the Max-Pass™ symbol.



LARGER CAPACITY...

per stroke than competitive models means less wear on moving parts.

BSP...

compatibility is accomplished through the use of slotted flanges on the 1", 1-1/2" and 2" models and BSP compatible threads are available on other models when requested.

PROCESS CONTROL...

Solenoid Control is optional for **Specialty Performance** and **Performance Plus** pumps. Cycle counting is optional for most pumps.

ATEX AND CE...

certification and quality control procedures have been obtained for all models.



Made in the USA

MATERIALS OF CONSTRUCTION

		Fluid Chambers	Diaphragms	Valve/Ball	Valve Seats	O-Rings	Fasteners
1/4" Classic Performance Models							
NC-025		Polypropylene	Geolast®	PTFE	Polypropylene	Nitrile	SS ²
NC-025E		Polypropylene	Santoprene®	PTFE	Polypropylene	EPDM	SS
BK-025		Polypropylene	PTFE	PTFE	Polypropylene	PTFE	SS
RD-025		Nylon	PTFE	PTFE	Nylon	PTFE	SS
RD-025B		Nylon	Geolast®	PTFE	Nylon	Nitrile	SS
CN-025		Conductive Nylon	PTFE	PTFE	Nylon	PTFE	SS
CN-025B		Conductive Nylon	Geolast®	PTFE	Nylon	Geolast®	SS
KN-025		PVDF	PTFE	PTFE	PVDF	PTFE	SS
KN-025E		PVDF	Santoprene®	PTFE	PVDF	EPDM	SS
3/8" Specialty Performance Plastic Models							
PB-038		Polypropylene	Geolast®	Nitrile Max-Pass™	N/A	Nitrile	SS ²
PE-038		Polypropylene	Santoprene®	EPDM Max-Pass™	N/A	EPDM	SS
PT-038		Polypropylene	PTFE	PTFE	Polypropylene	PTFE	SS
PV-038		Polypropylene	PTFE	Viton® Max-Pass™	N/A	Viton®	SS
KE-038		PVDF	Santoprene®	EPDM Max-Pass™	N/A	EPDM	SS
KT-038		PVDF	PTFE	PTFE	PVDF	PTFE	SS
KV-038		PVDF	PTFE	Viton® Max-Pass™	N/A	Viton®	SS
CT-038		Conductive Nylon	PTFE	PTFE	SS	PTFE	SS
CB-038		Conductive Nylon	Geolast®	Nitrile Max-Pass™	N/A	Nitrile	SS
CV-038		Conductive Nylon	PTFE	Viton® Max-Pass™	N/A	Viton®	SS
1/2" & 1" Performance Plus Models							
PB-05	PB-10	Polypropylene	Geolast®	Geolast®	Polypropylene	Nitrile	SS ²
PE-05	PE-10	Polypropylene	Santoprene®	Santoprene®	Polypropylene	EPDM	SS
PT-05	PT-10	Polypropylene	PTFE	PTFE	Polypropylene	PTFE	SS
PV-05	PV-10	Polypropylene	Viton®	Viton®	Polypropylene	Viton®	SS
NB-05		Nylon	Geolast®	Geolast®	PVDF	Nitrile	SS
NT-05		Nylon	PTFE	PTFE	PVDF	PTFE	SS
NV-05		Nylon	Viton®	Viton®	PVDF	Viton®	SS
CT-05		Conductive Nylon	PTFE	PTFE	SS	PTFE	SS
CB-05		Conductive Nylon	Geolast®	Geolast®	SS	Nitrile	SS
CV-05		Conductive Nylon	Viton®	Viton®	SS	Viton®	SS
KT-05	KT-10	PVDF	PTFE	PTFE	PVDF	PTFE	SS
KE-05	KE-10	PVDF	Santoprene®	Santoprene®	PVDF	EPDM	SS
KV-05	KV-10	PVDF	Viton®	Viton®	PVDF	Viton®	SS
AB-05	AB-10	Aluminum	Geolast®	Geolast®	Polypropylene	Nitrile	SS
AE-05	AE-10	Aluminum	Santoprene®	Santoprene®	Polypropylene	EPDM	SS
AT-05	AT-10	Aluminum	PTFE	PTFE	Nylon	PTFE	SS
AV-05	AV-10	Aluminum	Viton®	Viton®	Nylon	Viton®	SS
SB-05	SB-10	316 SS	Geolast®	Geolast®	SS	Nitrile	SS
SE-05	SE-10	316 SS	Santoprene®	Santoprene®	SS	EPDM	SS
SP-05	SP-10	316 SS	PTFE	PTFE	SS	PTFE	SS
SV-05	SV-10	316 SS	Viton®	Viton®	SS	Viton®	SS
1/2" & 1" Classic Performance Plastic Models							
NC-5	NC-10 ³	Polypropylene	Geolast®	Geolast®	Polypropylene	Nitrile	SS and PS ¹
BK-5	BK-10 ³	Polypropylene	PTFE	PTFE	Polypropylene	PTFE	SS
BK-5E	BK-10E ³	Polypropylene	Santoprene®	Santoprene®	Polypropylene	EPDM	SS
BK-5V	BK-10V ³	Polypropylene	Viton®	Viton®	Polypropylene	Viton®	SS
KN-5	KN-10	PVDF	PTFE	PTFE	PVDF	PTFE	SS
KN-5E	KN-10E	PVDF	Santoprene®	Santoprene®	PVDF	EPDM	SS
KN-5V	KN-10V	PVDF	Viton®	Viton®	PVDF	Viton®	SS
1-1/2", 2" & 3" Performance Plus Models							
PB-15	PB-20	Polypropylene	Geolast®	Geolast®	Polypropylene	Nitrile	SS ²
PT-15	PT-20	Polypropylene	PTFE	PTFE	Polypropylene	PTFE	SS
PE-15	PE-20	Polypropylene	Santoprene®	Santoprene®	Polypropylene	EPDM	SS
KT-15	KT-20	PVDF	PTFE	PTFE	PVDF	PTFE	SS
KE-15	KE-20	PVDF	Santoprene®	Santoprene®	PVDF	EPDM	SS
AB-15	AB-20	Aluminum	Geolast®	Geolast®	Polypropylene	Nitrile	SS
AE-15	AE-20	Aluminum	Santoprene®	Santoprene®	Polypropylene	EPDM	SS
AT-15	AT-20	Aluminum	PTFE	PTFE	Nylon	PTFE	SS
SB-15	SB-20	316 SS	Geolast®	Geolast®	SS	Nitrile	SS
SE-15	SE-20	316 SS	Santoprene®	Santoprene®	SS	EPDM	SS
SP-15	SP-20	316 SS	PTFE	PTFE	SS	PTFE	SS
	AL-30	Aluminum	Urethane	Geolast®	Nitrile	N/A	SS and PS
	AL-30E	Aluminum	Santoprene®	Santoprene®	EPDM	N/A	SS and PS
	AL-30T	Aluminum	PTFE	PTFE	Nylon	PTFE	SS and PS
	AL-30V	Aluminum	Viton®	Viton®	Viton®	N/A	SS and PS

DIAPHRAGM NOTES

- Geolast® is a nitrile based thermoplastic elastomer used in place of nitrile (Buna-N) or neoprene and urethane for non-aggressive water-based applications.
- Santoprene® is an EPDM-based thermoplastic elastomer and is resistant to mild acids, some solvents and bases.
- PTFE-stock models feature a two part diaphragm system in pumps 1/2" and larger.

NOTES

- 1 PS = Plated Steel
 - 2 SS = Stainless Steel
 - 3 Glass-filled polypropylene
- Santoprene® and Geolast® are registered trademarks of Advanced Elastomer Systems.
 - Viton® is a registered trademark of DuPont Dow Elastomers.
 - All air systems are glass-filled polypropylene.

READING THE PUMP CURVE

You must know the following data:

1. Required discharge pressure.
2. Air pressure available at the air inlet of the pump.
3. Required flow rate.

TO OBTAIN DISCHARGE PRESSURE:

Using the performance chart for a 1/2" pump shown: If 80 psi is available at the air inlet and the required capacity of the pump is 6 GPM. Follow the blue concave curve at 80 psi **1** as it slopes to the right and intersects with the 6 GPM vertical line **2**. By tracking horizontally back to the left (Y) axis, the discharge pressure is ascertained—65 psi **3**. (Right axis converts PSI to feet/meters).

TO OBTAIN REQUIRED AIR INLET PRESSURE:

Reverse the steps above:

Choose required discharge pressure (65 psi) **3** on left (Y) axis, go directly across the graph to the intersection of the correct flow rate (6 GPM) **2**, then track up and back toward the left (Y) axis along the blue curve; and the correct required air pressure can be obtained (80 psi) **1**.

Note: If greater outlet pressure vs. air inlet pressure is required—select a larger pump.

TO OBTAIN AIR CONSUMPTION:

The convex red lines represent the air consumption (standard cubic feet per minute), and the closest red line to where the blue line and the flow rate intersect **2** represents the air capacity required. On our example, the air consumption would be approximately 6 SCFM.

To convert SCFM to m³/h (N) multiply by 1.7

Performance Chart

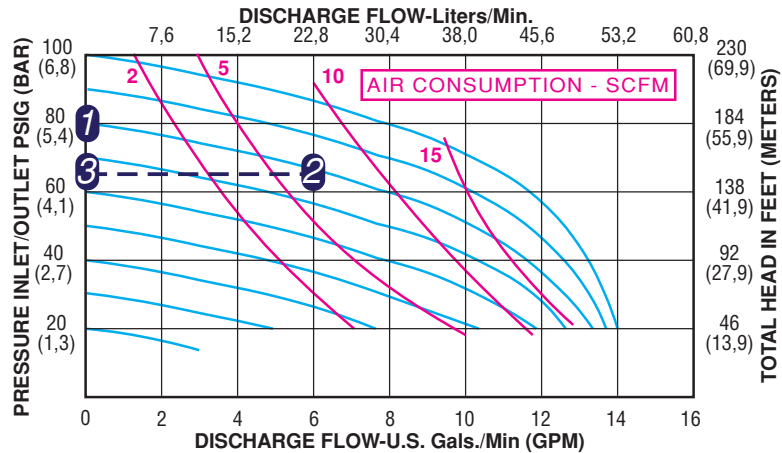

HIGH VISCOSITY APPLICATIONS

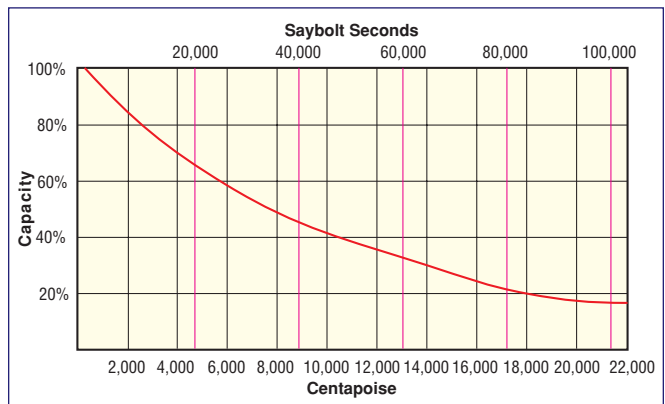

As you can see from the diagram above, as viscosities increase, the capacity of the pump decreases. Do not exceed 22,000 centipoise or 100,000 saybolt seconds on all 3/8" up to 3" pumps. Do not exceed 4,000 centipoise or 18,000 saybolt seconds on 1/4" models.

Some points to remember when pumping high viscosities:

1. Position the pump close to or below the level of the fluid source.
2. Suction lines should be increased in size—up to three times the size of the pump manifold inlet. Dual manifolds may be used when available.
3. Start the pump slowly using a control valve on the air line.
4. Maximum air pressure required is reached when increasing the air pressure does not increase the flow rate.
5. If greater capacity is required, select a larger pump.

INSTALLATION

1. A lube-free, clean, dry compressed air source (or any non-flammable, compressed gas) is recommended. Use a filter that is capable of filtering out particles larger than 50 microns.
2. Pumps should be mounted in an upright position with the exception of the 1/4" models or any pump with Max-Pass™ valves. These pumps can be mounted in any position.
3. Install a particle fluid filter on the fluid suction line when particles in the fluid exceed the maximum particle size specification of the pump or particles are sharp enough to cut the diaphragms.
4. Never restrict fluid suction lines by means of a reduced pipe size (smaller than pump inlet size) or control the pump with valves on the fluid inlet side of the pump.
5. Limit fluid inlet pressure to 10 PSIG or (.68 BAR)

1/4"

CLASSIC PERFORMANCE



PLASTIC MODELS:

NC-025 (Polypropylene/Geolast®)	5 lbs. (2,3 kg.)
NC-025E (Polypropylene/Santoprene®)	5 lbs. (2,3 kg.)
BK-025 (Polypropylene/PTFE)	5 lbs. (2,3 kg.)
RD-025 (Nylon/PTFE)	5 lbs. (2,3 kg.)
RD-025B (Nylon/Geolast®/PTFE)	5 lbs. (2,3 kg.)
CN-025 (Conductive Nylon/PTFE)	7 lbs. (3,2 kg.)
CN-025B (Conductive Nylon/Geolast®)	7 lbs. (3,2 kg.)
KN-025 (PVDF/PTFE)	7 lbs. (3,2 kg.)
KN-025E (PVDF/Santoprene®)	7 lbs. (3,2 kg.)

See page 4 for fastener and valve seat material.

SPECIFICATIONS:

Capacity:

Adjustable 0 to 4.3 GPM (16,3 liters/min.)

Maximum Temperature:

KN-025 Model 200°F (93°C)
Other Models 150°F (66°C)

Maximum Air Pressure:

All Models 100 PSI (6,8 bar)

Minimum Air Pressure:

All Models 20 PSI (1,3 bar)

Dry Lift:

All Models 17 ft. (5 meters)

Maximum Solids: 1/16" (1,6 mm)

Air Supply:

Inlet 1/4" NPT/BSP Female
Outlet 1/4" NPT/BSP Female
• Muffler supplied

Fluid Inlet/Discharge: 1/4" NPT/BSP Female

• For optional dual manifold inlet/outlet, add -P25 to Model No.

PLASTIC *Dimensions in inches and (mm).*

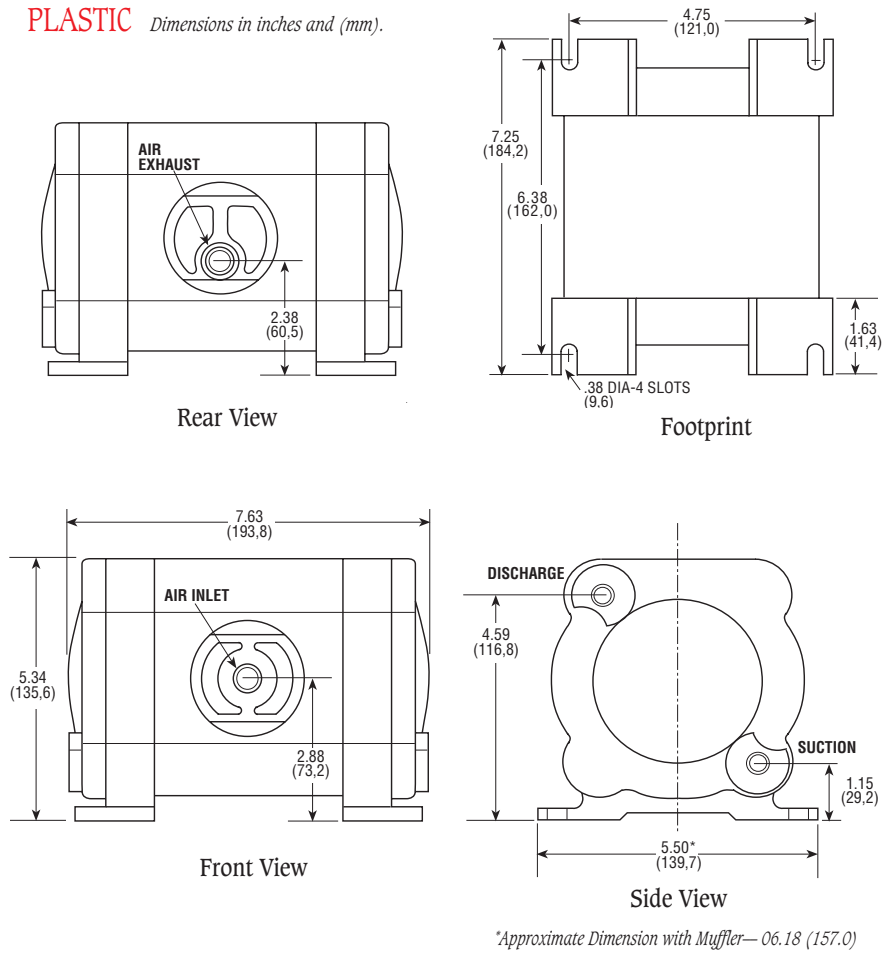

PERFORMANCE CURVE *(Based on water-flooded suction)*

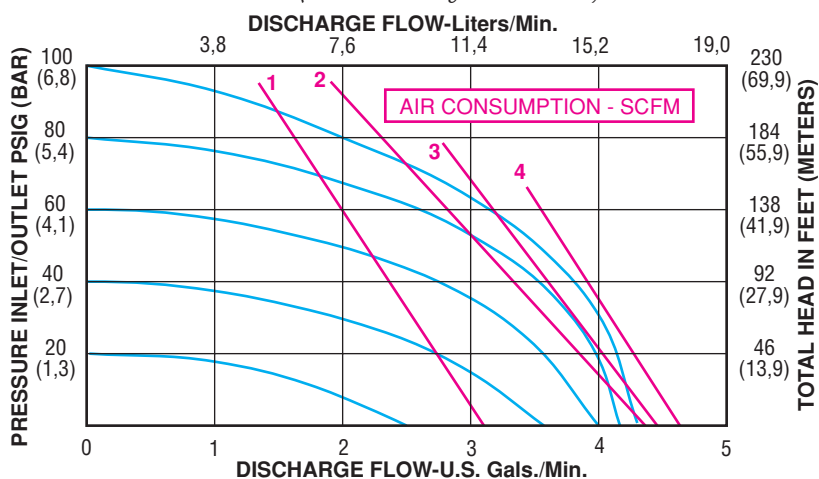

SPECIALTY PERFORMANCE

3/8"

Revolutionary Concept for Low-Flow Applications

Max-Pass™ Valve System – STANDARD

- 0-9 GPM (34 L/M)
- Up to 1/4" Solids
- Mounts in any position
- Drum Mounting Optional
- Abrasion resistant
- High Viscosity – *No Problem*
- Coagulating Fluids – *No Problem*
- Unplug additional ports when needed
- 17 foot suction lift
- Cycle Count Optional
- Solenoid Control Optional
- Low Shear
- Dual Manifold/Split Delivery Option *(See Note 1 below specifications)*

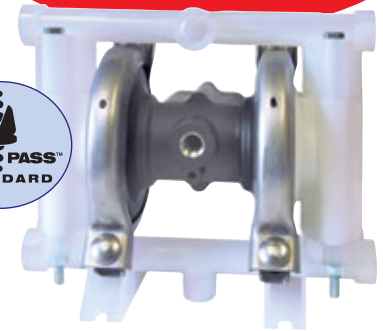

Ideal for inks, paints, adhesives, waste oil, coolant recycling, and other specialized applications

*Note: PT, KT, CT models are built with PTFE check balls (not Max-Pass™ valves)
See specifications for maximum solids.*

PLASTIC MODELS:

- PB-038** (Polypropylene/Geolast®/Nitrile) 3.8 lbs. (1,7 kg.)
- PE-038** (Polypropylene/Santoprene®/EPDM) 3.8 lbs. (1,7 kg.)
- PT-038** (Polypropylene/PTFE) 3.8 lbs. (1,7 kg.)
- PV-038** (Polypropylene/PTFE/Viton®) 3.8 lbs. (1,7 kg.)
- KE-038** (PVDF/Santoprene®/EPDM) 5 lbs. (2,3 kg.)
- KT-038** (PVDF/PTFE) 5 lbs. (2,3 kg.)
- KV-038** (PVDF/PTFE/Viton®) 5 lbs. (2,3 kg.)
- CT-038** (Conductive Nylon/PTFE) 5 lbs. (2,3 kg.)
- CB-038** (Conductive Nylon/Geolast®/Nitrile) 5 lbs. (2,3 kg.)
- CV-038** (Conductive Nylon/PTFE/Viton®) 5 lbs. (2,3 kg.)

SPECIFICATIONS:

- Capacity:**
Adjustable 0 to 9 GPM (34,0 liters/min.)
- Maximum Temperature:**
KT-038 Models 200°F (93°C)
Other Models 150°F (66°C)
- Maximum Air Pressure:**
All Models 120 PSI (8,2 bar)
- Minimum Air Pressure:**
All Models 20 PSI (1,3 bar)
- Dry Lift:**
Models w/PTFE balls 10 ft. (3 meters)
Models w/Max-Pass™ valves . . 17 ft. (5,2 meters)
- Maximum Solids (Max-Pass™ valves) . 1/4" (6,4 mm)**
PT, KT, CT models 1/16" (1,6 mm)

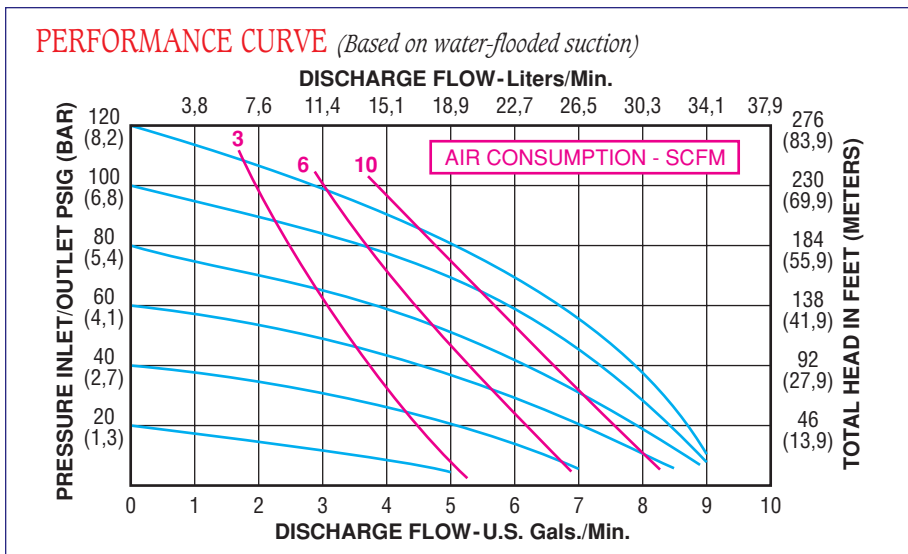
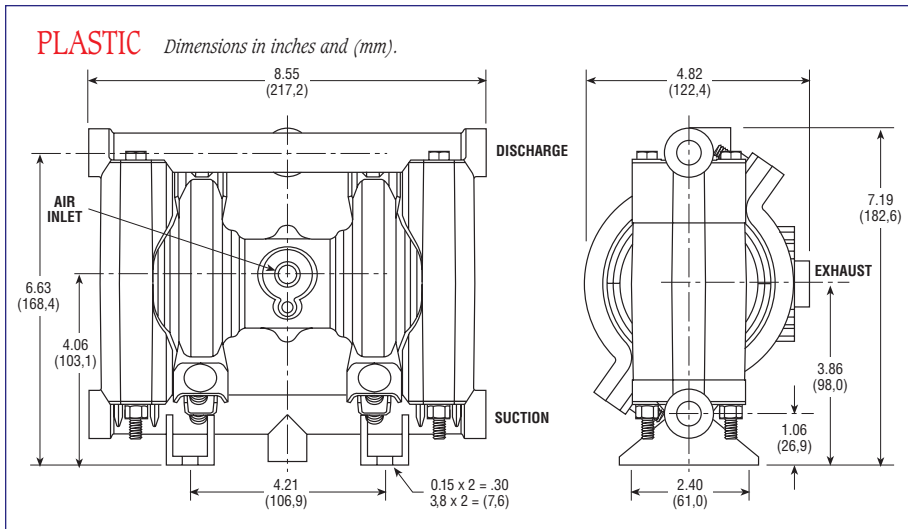

- Air Supply:**
Inlet 1/4" NPT/BSP Female
Outlet 3/8" NPT/BSP Female
- *Muffler supplied*
- Fluid Inlet/Discharge:**
All Models 3/8" NPT/BSP Female

- NOTE:**
1. Dual Manifold/Split Delivery is an option.
 - This option allows the pump to be used as two pumps in one, isolating different fluids when needed. See additional notes page 10.

1/2"

PERFORMANCE PLUS



PLASTIC MODELS:

PB-05 (Polypropylene/Geolast®)	9 lbs. (4,1 kg.)
PE-05 (Polypropylene/Santoprene®/EPDM)	9 lbs. (4,1 kg.)
PT-05 (Polypropylene/PTFE)	9 lbs. (4,1 kg.)
PV-05 (Polypropylene/Viton®)	9 lbs. (4,1 kg.)
NB-05 (Nylon/Geolast®/SS)	9 lbs. (4,1 kg.)
NT-05 (Nylon/PTFE/SS)	9 lbs. (4,1 kg.)
CB-05 (Conductive Nylon/Geolast®/SS)	12 lbs. (5,4 kg.)
CT-05 (Conductive Nylon/PTFE/SS)	12 lbs. (5,4 kg.)
KE-05 (PVDF/Santoprene®/EPDM)	12 lbs. (5,4 kg.)
KT-05 (PVDF/PTFE)	12 lbs. (5,4 kg.)
KV-05 (PVDF/Viton®)	12 lbs. (5,4 kg.)

METALLIC MODELS:

AB-05 (Aluminum/Geolast®)	10 lbs. (4,5 kg.)
AE-05 (Aluminum/Santoprene®/EPDM)	10 lbs. (4,5 kg.)
AT-05 (Aluminum/PTFE)	10 lbs. (4,5 kg.)
AV-05 (Aluminum/Viton®)	10 lbs. (4,5 kg.)
SB-05 (316 SS/Geolast®)	19 lbs. (8,6 kg.)
SE-05 (316 SS/Santoprene®/EPDM)	19 lbs. (8,6 kg.)
SP-05 (316 SS/PTFE)	19 lbs. (8,6 kg.)
SV-05 (316 SS/Viton®)	19 lbs. (8,6 kg.)

All fasteners are 18-8 stainless steel (comparable to 302-304).

SPECIFICATIONS:

Capacity:

Adjustable 0 – 17 GPM (64,6 liters/min.)

Maximum Temperature:

KT-05 Model 200°F (93°C)
 Other Plastic Models 150°F (66°C)
 Metallic Models 200°F (93°C)

Maximum Air Pressure:

All Models 120 PSI (8,2 bar)

Minimum Air Pressure:

All Models 20 PSI (1,3 bar)

Dry Lift:

Models w/ PTFE balls 10 ft. (3 meters)
 Other Ball Check models 15 ft. (4,5 meters)
 w/ optional Max-Pass™ valves 20 ft. (6 meters)

Maximum Solids:

Optional Max-Pass™ valves 3/8" (9,5 mm)

Air Supply:

Inlet 1/4" NPT/BSP Female
 Outlet 3/8" NPT/BSP Female

• Muffler supplied

Fluid Inlet/Discharge:

Models 1/2" NPS Female (BSP compatible)

• Stock models have a side port. Optional center, top or dual ports must be specified when ordering (See options page for code). Fluid is not separated within the single piece manifold when dual ports are specified.

• Dual Manifold/Split Delivery is an option.

PLASTIC

Dimensions in inches and (mm).

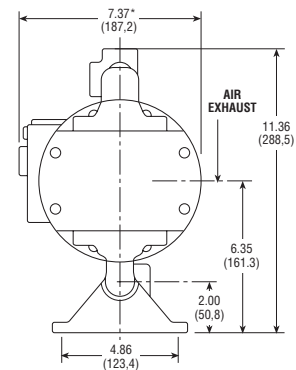
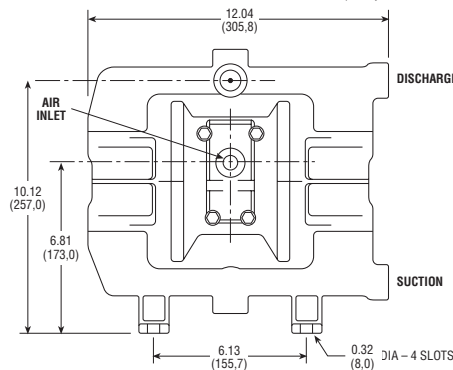

METALLIC

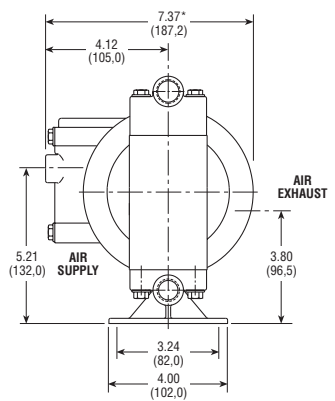
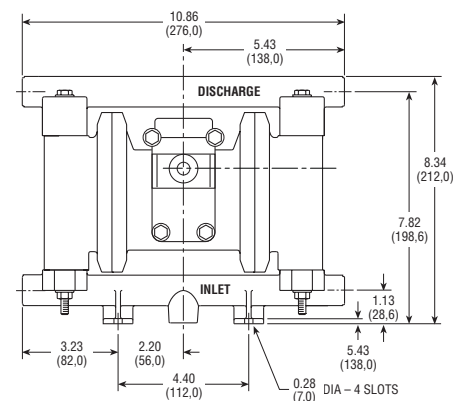

*Approximate Dimension with Muffler—7.37" (187,2)

PERFORMANCE CURVE (Based on water-flooded suction)

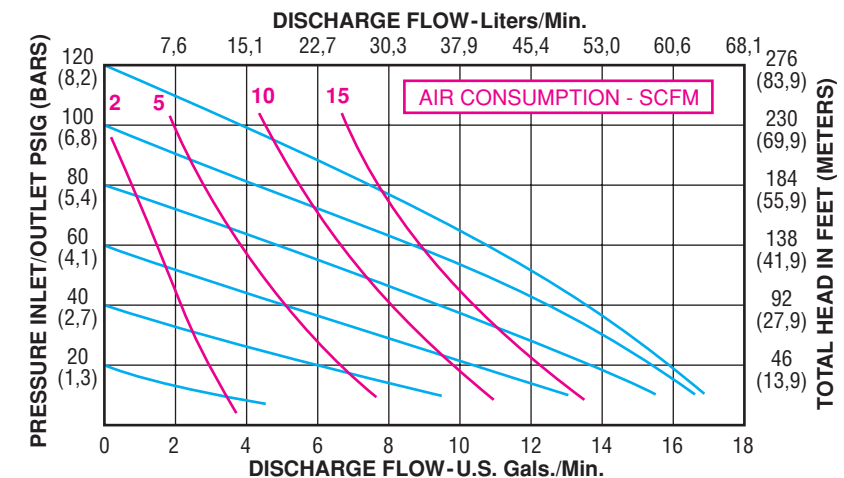

NEW OPTIONAL MAX-PASS™ VALVE SYSTEM

- Increases solids handling capability by 300% and suction lift by 25%
- Up to 3/8" solids for all 1/2" pumps
- Abrasion resistant
- Mounts in any position
- To order the Max-Pass™ valve system add the following code to the model number: -M4 (Nitrile), M5 (EPDM), M40 (Viton FDA)

Ideal for inks, paints, slurries, and other specialized applications

PERFORMANCE PLUS



PLASTIC Dimensions in inches and (mm).

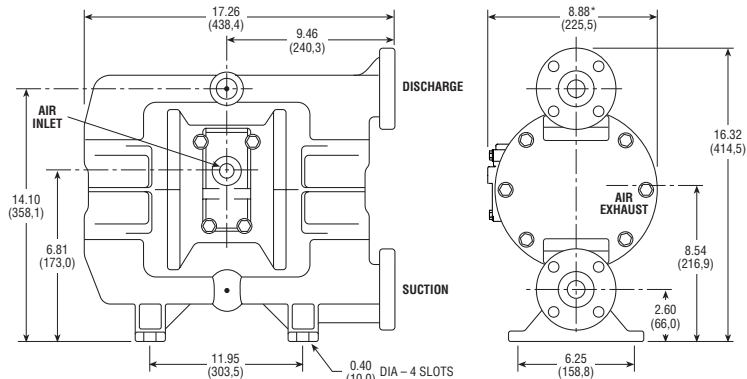

METALLIC Dimensions in inches and (mm).

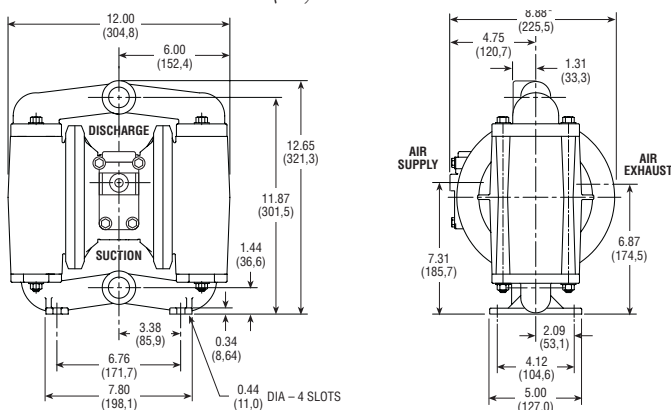

*Approximate Dimension with Muffler— 10.25 (260.4)

PLASTIC MODELS:

PB-10 (Polypropylene/Geolast®)	20 lbs. (9,1 kg.)
PE-10 (Polypropylene/Santoprene®/EPDM)	20 lbs. (9,1 kg.)
PT-10 (Polypropylene/PTFE)	20 lbs. (9,1 kg.)
PV-10 (Polypropylene/Viton®)	20 lbs. (9,1 kg.)
KT-10 (PVDF/PTFE)	30 lbs. (13,7 kg.)
KE-10 (PVDF/Santoprene®/EPDM)	30 lbs. (13,7 kg.)
KV-10 (PVDF/Viton®)	30 lbs. (13,7 kg.)

METALLIC MODELS:

AB-10 (Aluminum/Geolast®)	23 lbs. (10,5 kg.)
AE-10 (Aluminum/Santoprene®/EPDM)	23 lbs. (10,5 kg.)
AT-10 (Aluminum/PTFE)	23 lbs. (10,5 kg.)
AV-10 (Aluminum/Viton®)	23 lbs. (10,5 kg.)
SB-10 (316 SS/Geolast®)	45 lbs. (20,4 kg.)
SE-10 (316 SS/Santoprene®/EPDM)	45 lbs. (20,4 kg.)
SP-10 (316 SS/PTFE)	45 lbs. (20,4 kg.)
SV-10 (316 SS/Viton®)	45 lbs. (20,4 kg.)

All fasteners are 18-8 stainless steel (comparable to 302-304).

SPECIFICATIONS:

- Capacity:** Adjustable 0 – 41 GPM (155,8 liters/min.)
- Maximum Temperature:**
 - KT-10 Model 200°F (93°C)
 - Other Plastic Models 150°F (66°C)
 - Metallic Models 200°F (93°C)
- Maximum Air Pressure:**
 - All Models 120 PSI (8,2 bar)
- Minimum Air Pressure:**
 - All Models 20 PSI (1,3 bar)
- Dry Lift:**
 - Models w/ PTFE balls 10 ft. (3 meters)
 - Other Ball Check models 15 ft. (4,5 meters)
 - w/ optional Max-Pass™ valves . . 18 ft. (5,5 meters)
- Maximum Solids:** 1/4" (6,4 mm)
 - Max-Pass™ valves (plastic pumps) . . 3/4" (19 mm)
 - Max-Pass™ valves (metal pumps) . . 1/2" (12,7 mm)
- Air Supply:**
 - Inlet 1/4" NPT/BSP Female
 - Outlet 3/8" NPT/BSP Female

• Muffler supplied

Fluid Inlet/Discharge:

- Plastic Models . . . 1" Flange ANSI/DIN compatible
- Metallic Models 1" NPT

• For optional BSP threads add - P15 to Model No.

• For Plastic Pumps Only: Stock models have a flanged side port. Optional threaded center ports must be specified when ordering (See options page for code).

PERFORMANCE CURVE (Based on water-flooded suction)

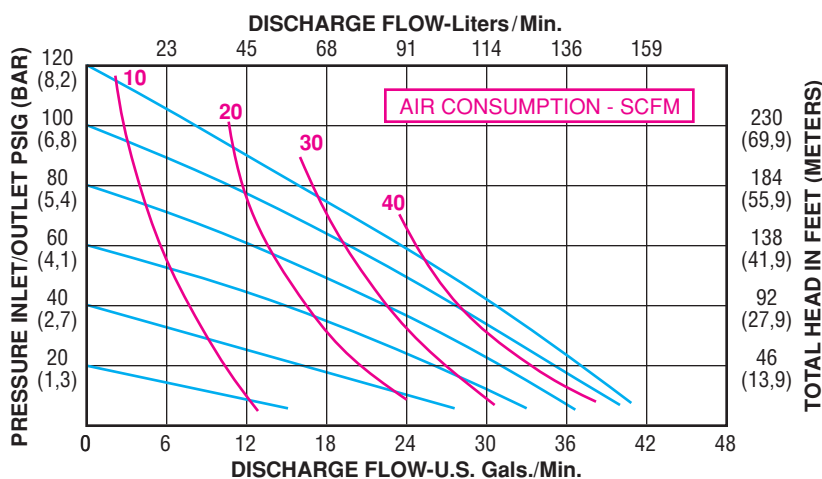

NEW OPTIONAL MAX-PASS™ VALVE SYSTEM

- Increases solids handling capability by 300% and suction lift by 25%
- Up to 3/4" solids for all 1" pumps
- Abrasion resistant
- Mounts in any position
- To order the Max-Pass™ valve system add the following code to the model number: -M4 (Nitrile), M5 (EPDM), M40 (Viton FDA)

Ideal for inks, paints, slurries, and other specialized applications

1/2" • 1"

CLASSIC PERFORMANCE

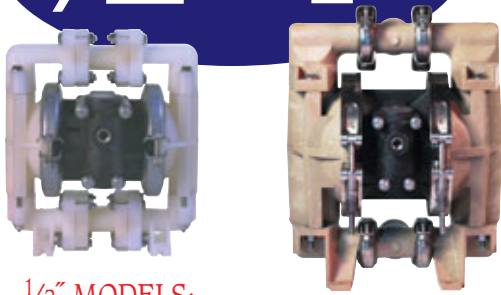

1/2" MODELS:

- NC-5** (Polypropylene/Geolast®) 8 lbs. (3,6 kg.)
- BK-5** (Polypropylene/PTFE) 8 lbs. (3,6 kg.)
- BK-5E** (Polypropylene/Santoprene®) 8 lbs. (3,6 kg.)
- KN-5** (PVDF/PTFE) 11 lbs. (4,9 kg.)
- KN-5E** (PVDF/Santoprene®) 11 lbs. (4,9 kg.)

1" MODELS:

- NC-10** (Polypropylene/Geolast®) 19 lbs. (8,6 kg.)
- BK-10** (Polypropylene/PTFE) 19 lbs. (8,6 kg.)
- BK-10E** (Polypropylene/Santoprene®) 19 lbs. (8,6 kg.)
- KN-10** (PVDF/PTFE) 22 lbs. (9,9 kg.)
- KN-10E** (PVDF/Santoprene®) 22 lbs. (9,9 kg.)

See page 4 for fastener and valve seat material.

SPECIFICATIONS:

Maximum Temperature:

- KN Models 200°F (93°C)
- Other Models 150°F (66°C)

Maximum Air Pressure: 100 PSI (6,8 bar)

Minimum Air Pressure: 20 PSI (1,3 bar)

Dry Lift:

- Models w/PTFE balls 10 ft. (3 meters)
- Other Models 15 ft. (4,5 meters)

SPECIFICATIONS (1/2" MODELS):

Capacity:

- Adjustable 0 to 14 GPM (53,2 liters/min.)

Maximum Solids: 1/8" (3,2 mm)

Air Supply:

- Inlet 1/4" NPT Female
- Outlet 3/8" NPT Female
- Muffler supplied

Fluid Inlet/Discharge:

- All Models 1/2" NPS Female (BSP or NPT Compatible)
- For optional dual manifold inlet/outlet, add -P25 to Model No.

SPECIFICATIONS (1" MODELS):

Capacity:

- Adjustable 0 to 40 GPM (152 liters/min.)

Maximum Solids: 1/4" (6,4 mm)

Air Supply:

- Inlet 1/4" NPT Female
- Outlet 3/8" NPT Female
- Muffler supplied

Fluid Inlet/Discharge: 1" NPT

- For optional BSP threads, add -P15 to Model No.

PLASTIC Dimensions in inches and (mm). Ports shown facing front for dimensional purposes.

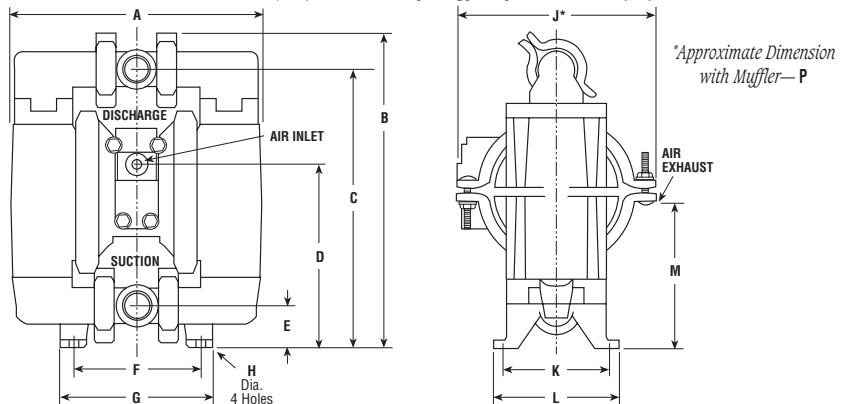

MODEL	DIMENSIONS Inches / (mm)												
SIZE	A	B	C	D	E	F	G	H	J	K	L	M	P
1/2" Models	9.76 (248,0)	10.75 (273,0)	9.38 (238,0)	6.19 (157,2)	1.38 (35,0)	5.70 (145,0)	6.70 (170,0)	0.31 (8,0)	7.50 (190,5)	3.26 (83,0)	4.00 (102,0)	5.12 (130,0)	8.00 (203,2)
1" Models	12.00 (305,0)	15.50 (394,0)	13.50 (343,0)	8.30 (211,0)	2.00 (51,0)	5.74 (146,0)	7.62 (194,0)	0.44 (11,2)	9.90 (252,0)	5.12 (130,0)	6.00 (152,4)	8.30 (211,0)	11.57 (293,9)

PERFORMANCE CURVE (1/2" MODELS)

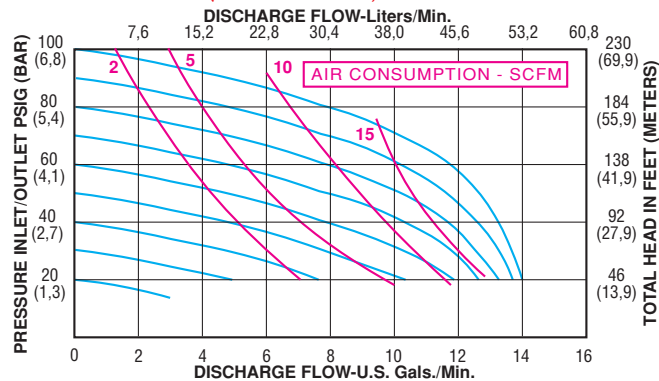

PERFORMANCE CURVE (1" MODELS)

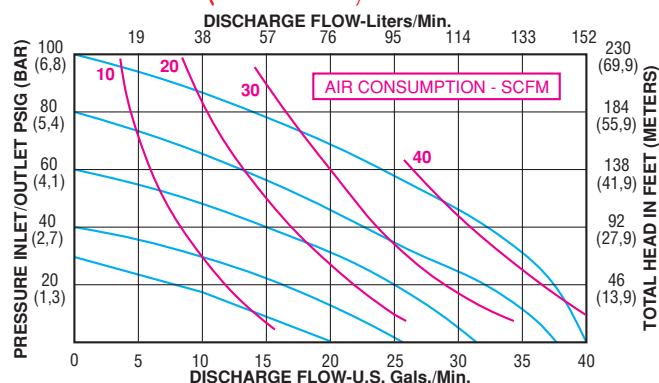

Dual Manifold/Split Delivery

1. The pump can be used as two pumps in one, isolating two different fluids or recycling on one side and using the opposite side for delivery.
 2. A dual manifold used only on the suction side of the pump can be used to mix two different fluid that must be kept separate prior to transfer such as a two part epoxy.
 3. A dual manifold used only on the discharge side of the pump will split the delivery.
- Add -P25 after the model number to have the pump configured at the factory with dual manifolds.
 - Fluid must be transferred through both sides of the pump.

PERFORMANCE PLUS

1 1/2"

NEW



PLASTIC *Dimensions in inches and (mm).*

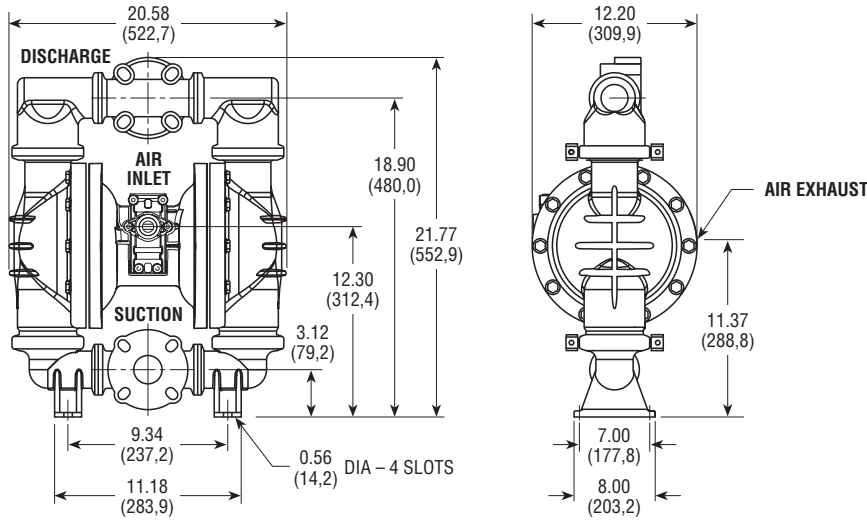

METALLIC

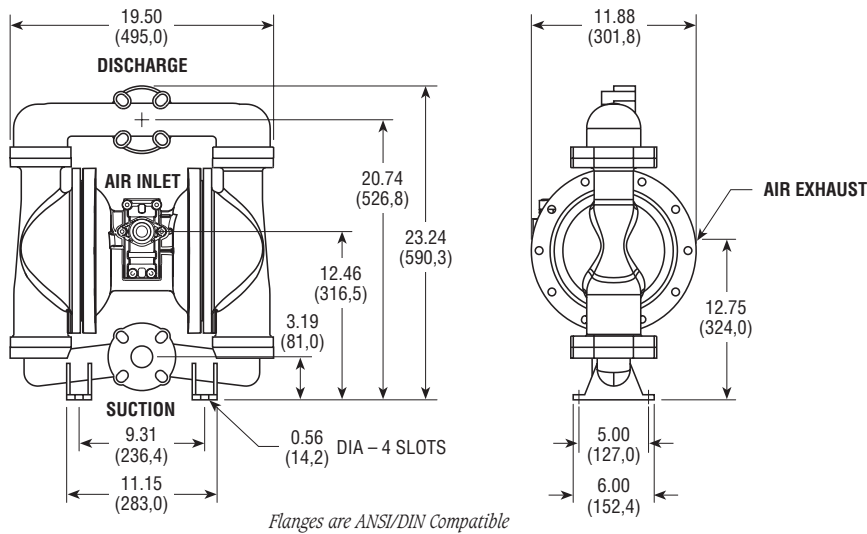

PLASTIC MODELS:

- PB-15** (Polypropylene/Geolast®) 46 lbs. (20,8 kg.)
- PT-15** (Polypropylene/PTFE) 46 lbs. (20,8 kg.)
- PE-15** (Polypropylene/Santoprene®) 46 lbs. (20,8 kg.)
- KT-15** (PVDF/PTFE) 65 lbs. (29,4 kg.)
- KE-15** (PVDF/Santoprene®) 65 lbs. (29,4 kg.)

METALLIC MODELS:

- AB-15** (Aluminum/Geolast®) 60 lbs. (27,2 kg.)
- AE-15** (Aluminum/Santoprene®) 60 lbs. (27,2 kg.)
- AT-15** (Aluminum/PTFE) 60 lbs. (27,2 kg.)
- SP-15** (316 Stainless Steel/PTFE) 133 lbs. (60 kg.)
- SE-15** (316 Stainless/Santoprene®) 133 lbs. (60 kg.)
- SB-15** (316 Stainless/Geolast®) 133 lbs. (60 kg.)

See page 4 for fastener and valve seat material.

SPECIFICATIONS:

- Capacity:**
Adjustable 0 to 130 GPM (492 liters/min.)
- Maximum Temperature:**
KT-15 Model 200°F (93°C)
Other Plastic Models 150°F (66°C)
Metallic Models 200°F (93°C)

- Maximum Air Pressure:**
All Models 120 PSI (8,2 bar)

- Minimum Air Pressure:**
All Models 20 PSI (1,3 bar)

- Dry Lift:**
Models w/PTFE balls 10 ft. (3 meters)
Other Models 15 ft. (4,5 meters)

- Maximum Solids:** 1/4" (6,4 mm)

- Air Supply:**
Inlet 3/4" NPT/BSP Female
Outlet 3/4" NPT/BSP Female
• *Muffler supplied*

- Fluid Inlet/Discharge:** . . 1-1/2" Flange (38,1 mm)
• *Flanges are ANSI and DIN compatible*
• *Threaded companion flanges available*

PERFORMANCE CURVE

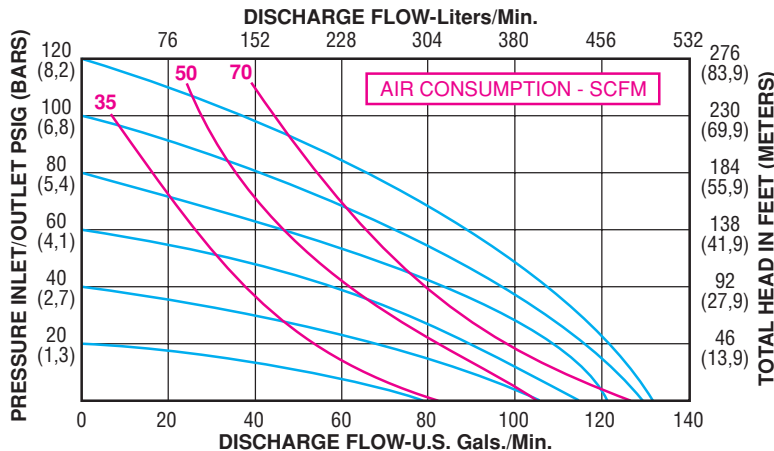

PERFORMANCE PLUS

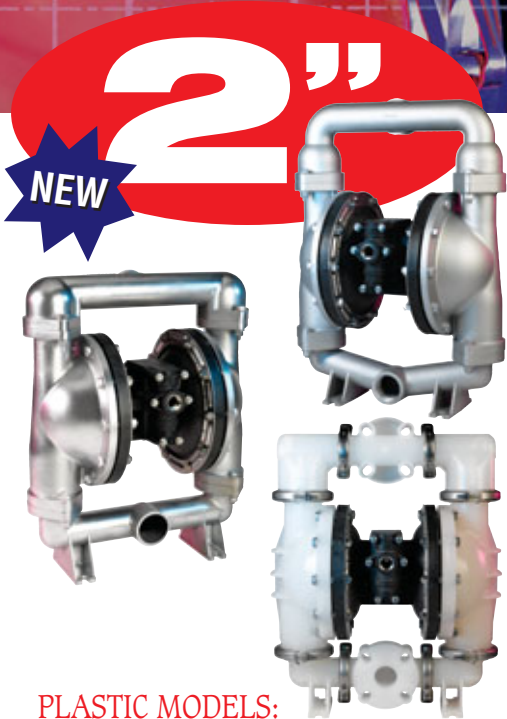

PLASTIC MODELS:

- PB-20** (Polypropylene/Geolast®) 48 lbs. (21,7 kg.)
- PT-20** (Polypropylene/PTFE) 48 lbs. (21,7 kg.)
- PE-20** (Polypropylene/Santoprene®) 48 lbs. (21,7 kg.)
- KT-20** (PVDF/PTFE) 69 lbs. (31,3 kg.)
- KE-20** (PVDF/Santoprene®) 69 lbs. (31,3 kg.)

METALLIC MODELS:

- AB-20** (Aluminum/Geolast®) 61 lbs. (27,7 kg.)
- AE-20** (Aluminum/Santoprene®) 61 lbs. (27,7 kg.)
- AT-20** (Aluminum/PTFE) 61 lbs. (27,7 kg.)
- SP-20** (316 Stainless Steel/PTFE) 133 lbs. (60 kg.)
- SB-20** (316 Stainless/Geolast®) 133 lbs. (60 kg.)
- SE-20** (316 Stainless/Santoprene®) 133 lbs. (60 kg.)

See page 4 for fastener and valve seat material.

SPECIFICATIONS:

- Capacity:**
Adjustable 0 to 180 GPM (681 liters/min.)
- Maximum Temperature:**
KT-20 Model 200°F (93°C)
Other Plastic Models 150°F (66°C)
Metallic Models 200°F (93°C)
- Maximum Air Pressure:**
All Models 120 PSI (8,2 bar)
- Minimum Air Pressure:**
All Models 20 PSI (1,3 bar)
- Dry Lift:**
Models w/PTFE balls 10 ft. (3 meters)
Other Models 15 ft. (4,5 meters)
- Maximum Solids:** 1/4" (6,4 mm)
- Air Supply:**
Inlet 3/4" NPT/BSP Female
Outlet 3/4" NPT/BSP Female
- Muffler supplied
- Fluid Inlet/Discharge:** 2" (51mm) Flange
1. Plastic Pumps – ANSI and DIN flanges
 - Threaded companion flanges available
 2. Metal Pumps – 2" NPT threads standard
 - 2" (51mm) BSP threads optional – Add -P15 to Model No.
 3. Stainless Pump Option
 - Tri-Clamp Fittings – Add -X44 to Model No.

PLASTIC Dimensions in inches and (mm).

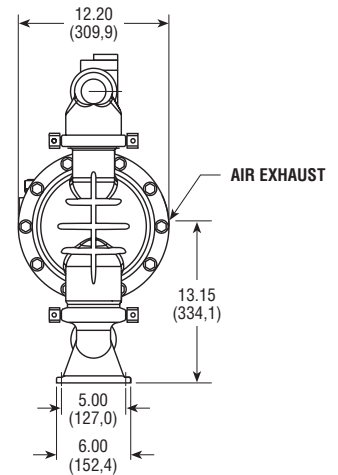
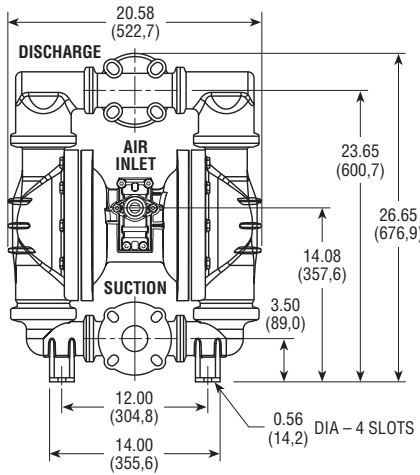

METALLIC

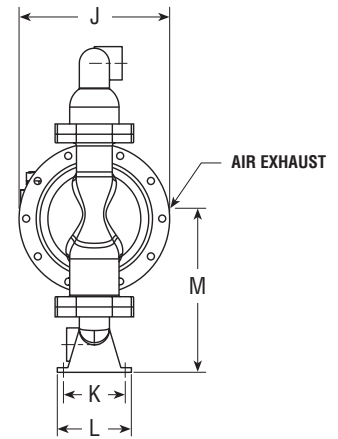
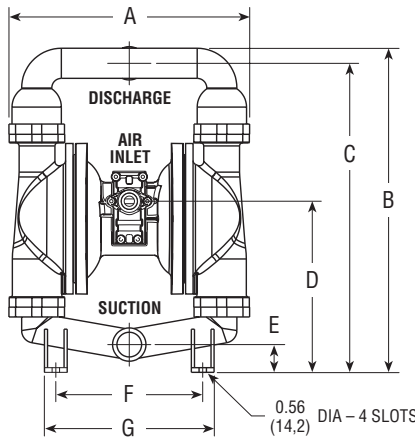

MODEL	DIMENSIONS Inches / (mm)										
SIZE (Inlet/Outlet)	A	B	C	D	E	F	G	J	K	L	M
2" Aluminum NPT & BSP	19.50 (495.0)	26.26 (667.0)	25.04 (636.0)	13.86 (352.0)	2.25 (57.1)	10.06 (255.5)	12.00 (304.8)	12.20 (309.9)	5.00 (127.0)	6.00 (152.4)	12.90 (327.6)
2" Stainless Steel NPT & BSP	19.50 (495.0)	24.62 (625.3)	23.00 (584.2)	15.05 (382.3)	3.50 (89.0)	12.00 (304.8)	13.85 (351.5)	12.20 (309.9)	5.00 (127.0)	6.00 (152.4)	14.10 (358.1)
Metal Flange Optional 2" Flange	19.50 (495.0)	24.62 (625.3)	21.62 (549.2)	13.25 (336.6)	3.50 (89.0)	12.00 (304.8)	13.85 (351.5)	11.88 (301.8)	5.00 (127.0)	6.00 (152.4)	12.75 (324.0)

PERFORMANCE CURVE

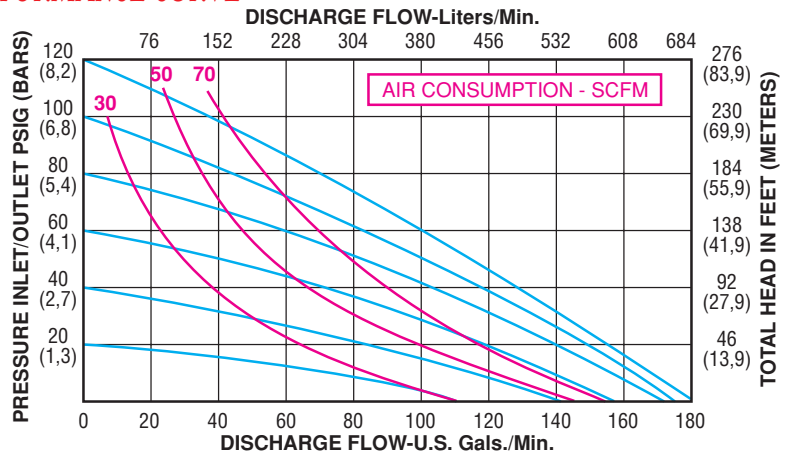

PERFORMANCE PLUS

3"

METALLIC Dimensions in inches and (mm). Ports shown facing front for dimensional purposes.

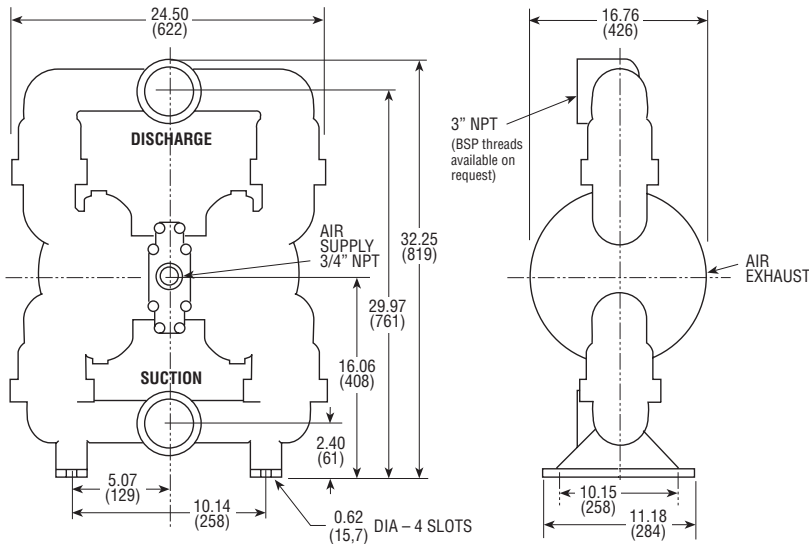

METALLIC MODELS:

- AL-30** (Aluminum/Urethane/Geolast®) 130 lbs. (59 kg.)
- AL-30E** (Aluminum/Santoprene®/EPDM) 130 lbs. (59 kg.)
- AL-30T** (Aluminum/PTFE) 130 lbs. (59 kg.)
- AL-30V** (Aluminum/Viton®) 130 lbs. (59 kg.)

SPECIFICATIONS:

- Capacity: Adjustable 0 to 255 GPM (965 liters/min.)
- Maximum Temperature: All Models 200°F (93°C)
- Maximum Air Pressure: All Models 120 PSI (8,2 bar)
- Minimum Air Pressure: All Models 20 PSI (1,3 bar)
- Dry Lift: Models w/PTFE balls 10 ft. (3 meters)
Other Models 15 ft. (4,5 meters)
- Maximum Solids: 7/16" (11,1 mm)
- Air Supply: Inlet 3/4" NPT/BSP Female
Outlet 3/4" NPT/BSP Female
• Muffler supplied
- Fluid Inlet/Discharge: Metallic Models 3" NPT Female
• For optional BSP threads add -P15 to Model No.

PERFORMANCE CURVE (Based on water-flooded suction)

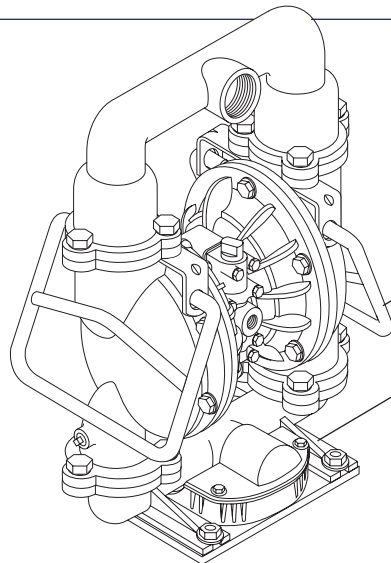
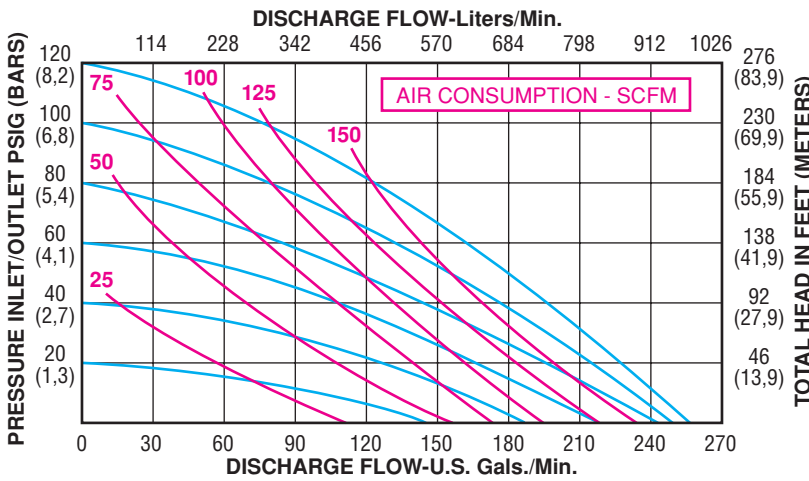

Optional 3" Pump Accessories

- **Carry Handles**
Part No. 52000
(Kit contains 2 handles)
- **Strainer Base**
Part No. 53000

OPTIONAL PUMP ACCESSORIES

PROCESS CONTROL FOR ALL-FLO PUMPS

Cycle Counting

Every time a cycle is completed, an impulse is sent from the cycle count valve to a data acquisition center for automated input to a PC, PLC, relay or switch. Measuring how much fluid is being transferred through the pump based on the number of elapsed cycles is a convenient method for:

- 1) monitoring how much additive a system has received or
 - 2) adding a precise dose of fluid based on a set number of cycles.
- Cycle based maintenance rather than time interval maintenance is ideal for systems where the fluid is hazardous or abrasive. Elapsed cycles can be monitored from any workstation within a network.

The cycle count valve is integral to the air valve. The sensor at the bottom of the air valve is provided (*see photo*). The configuration for data acquisition and control is not provided.

To order a pump with the cycle count valve assembled on the pump, add Option Code -A42 to the pump model number.

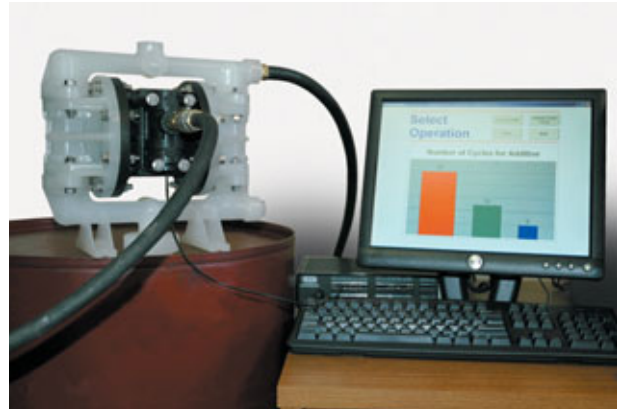

Solenoid Control (Optional for Specialty Performance and Performance Plus)

The solenoid control valve is used for remote, electrical control of an All-Flo pump through a PC, PLC, relay or switch. The solenoid control valve can be operated from any workstation in a network.

The solenoid control valve replaces the air valve assembly. The solenoid is mounted onto the intermediate using an adaptor plate. When energized, air is delivered to one side of the pump while simultaneously exhausting the other side. The reverse occurs when the valve is de-energized.

World standard connections and coil voltage are available. The control signal is a solution to 'on demand' fluid transfer requirements or the pump can be used to monitor flow rate.

To order the solenoid control valve, add -A43-XX to the model number with the voltage requirement replacing the 'XX'.



Both the Cycle Counter and Solenoid control valves are designed to make your All-Flo pump an integral component of your process. Chemical, ink, paint pigment and adhesive transfer are just a few of the literally thousands of applications requiring process control. *Note:* The cycle count and solenoid control valves can be used on pumps 3/8" and larger. Contact your All-Flo distributor for pricing and application information.

DRUM KITS

The many advantages of diaphragm pumps make them ideal for drum evacuation. All-Flo has taken the guesswork out of this application. When ordering an All-Flo pump with a drum mounting kit, the bottom port is positioned for immediate assembly, and a universal bung adaptor and compatible suction tube are provided. All the components necessary for the perfect drum pump!

Add a 'D' after the model code (e.g., PED-05) to receive the drum configuration. Drum mounting kits are available for pumps up to 1" in size. Contact your All-Flo distributor for compatible pump models.





BUILT FOR THE REAL WORLD

ALL-FLO pumps are providing trouble-free service on all types of industrial applications worldwide. Whatever the application, industry or operating environment, your ALL-FLO distributor is ready to help you select the right pump for your application and work with you to ensure trouble-free operation.



EACH ALL-FLO PUMP IS BACKED BY A 5-YEAR WARRANTY AND TESTED BEFORE SHIPMENT.

Your All-Flo Double Diaphragm Pump is warranted to the original user against defects in workmanship or materials under normal use (rental use excluded) for five years after purchase date. Any pump which is determined to be defective in material and workmanship and returned to All-Flo Pump Co., shipping costs prepaid, will be repaired or replaced at All-Flo's option.

This warranty does not cover failure of parts or components due to normal wear or damage or failure which in the judgment of All-Flo arises from misuse, abrasion, corrosion, negligence, accidental damage, faulty installation or tampering. If All-Flo inspection discloses no defect in material or workmanship, repair or replacement and return will be made at customary charges.

All-Flo has made a diligent effort to accurately illustrate and describe its product in this literature. However, such illustrations and descriptions are not a warranty. THE ABOVE EXPRESS WARRANTY IS IN LIEU OF AND EXCLUDES ALL OTHER WARRANTIES, EXPRESS OR IMPLIED, INCLUDING, WITHOUT LIMITATION, MERCHANTABILITY OR FITNESS FOR A PARTICULAR PURPOSE.

Purchaser shall give written notice of any claim to All-Flo within ten days after discovery of any alleged defect. ALL-FLO SHALL NOT BE LIABLE FOR CONSEQUENTIAL DAMAGES, LOSSES, DELAYS, LABOR COSTS OR ANY OTHER EXPENSE DIRECTLY OR INDIRECTLY ARISING FROM USE OF THE PUMP, ITS LIABILITY BEING EXPRESSLY LIMITED TO THE REPLACEMENT OR REPAIR OF ANY DEFECTIVE PUMP OR AN ALLOWANCE OF CREDIT THEREFORE. THE REMEDY AND RECOVERY OF THE PURCHASER ON ANY CLAIM AGAINST ALL-FLO, WHETHER BASED ON CONTRACT, THIS WARRANTY OR ANY ALLEGED NEGLIGENCE SHALL BE AS STATED AND LIMITED HEREIN AND SHALL BE EXCLUSIVE.



Performance Plus Pumps



Classic Performance Pumps



Specialty Performance

ALL-FLO

PUMP COMPANY, INC.

Made in the USA
Bulletin AF-111-1/07 Printed in U.S.A. 10M107

9321 Pineneedle Drive, Mentor, Ohio 44060
Phone: 440.354.1700 Fax: 440.354.9466
Business Site: www.all-flo.com E-Mail: sales@all-flo.com